

SPECIFICATIONS
DIESEL ENGINE FOR MARINE USE

HINO W04C-TI

3.839 liters, 4-cycle,
4-cyl., water-cooled,
turbocharged and intercooled

● ENGINE DESCRIPTION

- | | |
|--|---|
| 1. Max. output, pleasure craft | 157 kW (210 HP)/3,000 rpm |
| 2. Max. output, work boat
(light duty) | 138 kW (185 HP)/3,000 rpm |
| 3. Type | Diesel, 4-cycle, 4-cyl., in-line, over-head valve, water-cooled |
| 4. Aspiration | Turbocharged and intercooled |
| 5. Combustion system | Direct injection |
| 6. Cylinder
Bore x Stroke | 104 x 113 mm (4.09 x 4.45 in.) |
| 7. Piston displacement | 3.839 liter (234.2 cu.in.) |
| 8. Compression ratio | 16.5 |
| 9. Direction of rotation | Counter-clockwise viewed from flywheel |
| 10. Dimensions with marine
gear (L x W x H) | Approx. 1,152 x 694 x 790 mm
(45.4 x 27.3 x 31.1 in.) |
| 11. Dry weight with marine
gear | Approx. 540 kg (1,191 lb) |

● FEATURES

- | | |
|---------------------|--|
| 1. Cylinder block | Mono block cast iron with replaceable dry liner |
| 2. Cylinder head | Single piece cast iron |
| 3. Crankshaft | Induction hardened die forged special steel with counter weights |
| 4. Piston and rings | Heat resistance aluminum alloy
Two compression rings, chrome plated
One oil ring, chrome plated with coil expander |
| 5. Camshaft | Induction hardened carbon steel |
| 6. Valves | Heat resistance steel |

- EQUIPMENT

- ENGINE

- | | |
|--------------------------|--|
| 1. Flywheel housing | SAE No. 3 |
| 2. Flywheel | SAE 11½ |
| 3. Fuel injection pump | BOSCH "AD" type with all speed governor |
| 4. Fuel filter | Paper element type |
| 5. Water separator | Equipped |
| 6. Lube oil pump | Full forced pressure feed by gear pump |
| 7. Lube oil filter | Paper element type (Full flow) |
| 8. Lube oil cooler | Multi plate type, Fresh water cooled |
| 9. Fresh water pump | Forced-circulation by volute pump |
| 10. Raw water pump | Self priming, Rubber impeller type |
| 11. Intake manifold | Inlet position at rear |
| 12. Exhaust manifold | Fresh water-cooled exhaust manifold, integrated heat exchanger with expansion tank |
| 13. Turbocharger | Cooled by fresh water, with air cleaner |
| 14. Intercooler | Cooled by raw water |
| 15. Starter | 12V, 2.5 KW |
| 16. Alternator | 12V, 50A, with built-in voltage regulator |
| 17. Engine stop solenoid | Equipped |
| 18. Emergency stop relay | Equipped |
| 19. Starter block relay | Equipped |
| 20. Glow plug | Equipped |
| 21. Rigid mount bracket | Equipped |
| 22. Exhaust riser | Cooled by raw water |
| 23. Marine gear | Equipped |

- INSTRUMENT PANEL

1. Battery switch
2. Starter switch with key
3. Instrument panel lamp switch
4. Tachometer (with hourmeter and trip meter)
5. Coolant temperature gauge
6. Oil pressure gauge
7. Fuel gauge
8. Volt meter
9. Pre-heater indicator lamp
10. Coolant temperature warning lamp
11. Charge warning lamp
12. Oil pressure warning lamp

HOW TO USE THIS WORKSHOP MANUAL.

This workshop manual is designed as a guide for servicing engine.

An INDEX is provided on the first page of each chapter. TROUBLESHOOTING is dealt with each chapter.

When beginning operations, refer to the sections on for guide to appropriate diagnoses.

SPECIAL TOOLS are dealt with in each chapter.

When ordering a special tool, make sure that the parts number is correct.

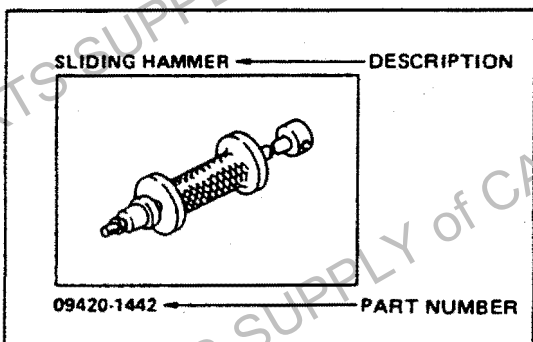

REPAIR PROCEDURES

Repair procedures which are self-explanatory such as simple installation and removal of parts have been omitted. Illustrations such as the one below have been provided to make such simple procedures clear. Only essential procedures requiring directions have been dealt with explicitly.

EXAMPLE:

TIMING GEAR AND CAMSHAFT

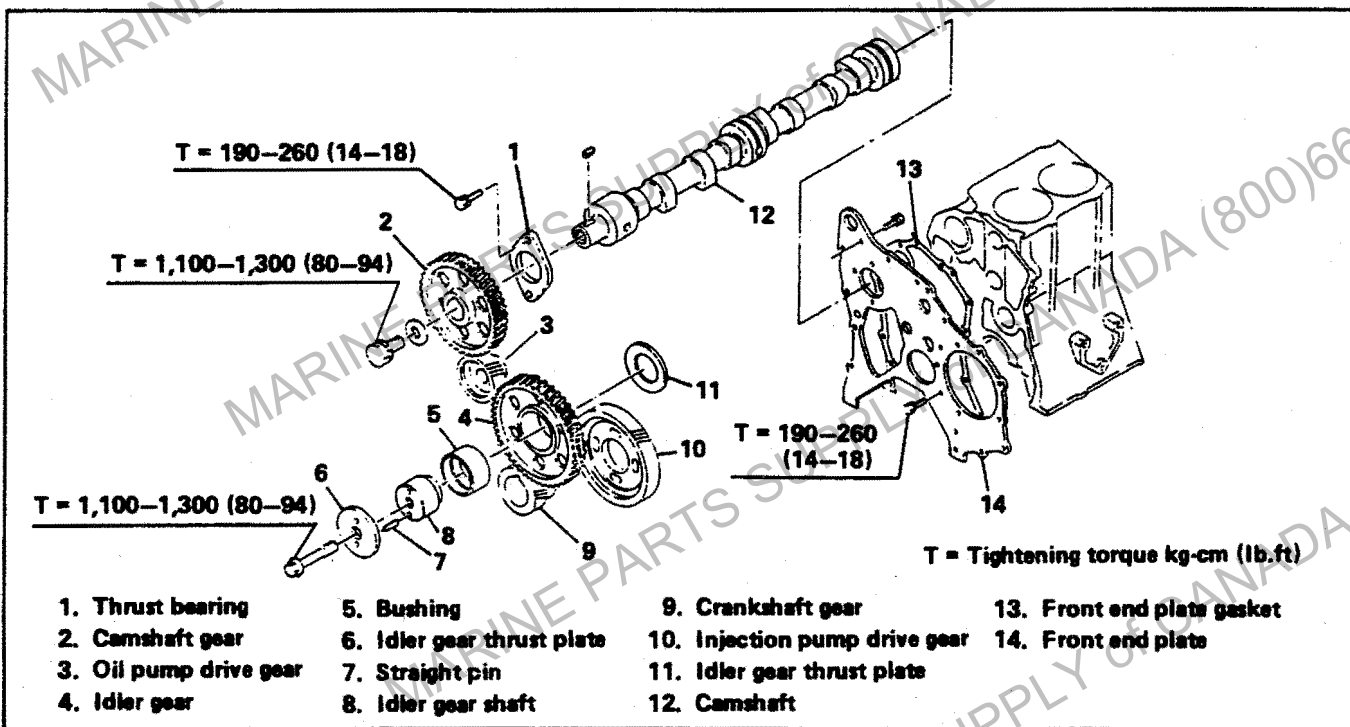

In some cases, illustrations may be of parts which differ in some nonessential way from the parts found on your particular engine. In such cases, however, the principle or procedure being illustrated applies regardless of such non-essential differences.

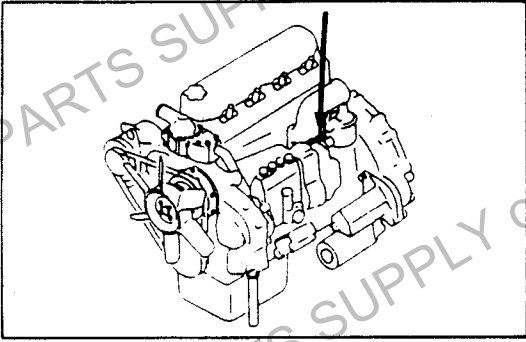

IDENTIFICATION INFORMATION

ENGINE SERIAL NUMBERS

Please quote these numbers when ordering spare parts or reporting technical matter as they will give you prompt service attention.

The engine serial number is engraved on the engine cylinder block.

SPECIFICATIONS
DIESEL ENGINE FOR MARINE USE

HINO W04D

4.009 liters, 4-cycle,
4-cyl., water-cooled

● ENGINE DESCRIPTION

- | | |
|---|---|
| 1. Max. output, pleasure craft | 82 kW (110HP)/3,000 rpm |
| 2. Max. output, work boat
(light duty) | 69 kW (92 HP)/3,000 rpm |
| 3. Type | Diesel, 4-cycle, 4-cyl., in-line, over-head valve, water-cooled |
| 4. Aspiration | Natural aspirate |
| 5. Combustion system | Direct injection |
| 6. Cylinder
Bore x Stroke | 104 x 118 mm (4.09 x 4.65 in.) |
| 7. Piston displacement | 4.009 liter (244.6 cu.in.) |
| 8. Compression ratio | 17.9 |
| 9. Direction of rotation | Counter-clockwise viewed from flywheel |
| 10. Dimensions without marine
gear (L x W x H) | Approx. 1,026 x 691 x 790 mm
(40.4 x 27.2 x 31.1 in.) |
| 11. Dry weight without marine
gear | Approx. 385 kg (850 lb) |

● FEATURES

- | | |
|---------------------|--|
| 1. Cylinder block | Mono block cast iron with replaceable dry liner |
| 2. Cylinder head | Single piece cast iron |
| 3. Crankshaft | Induction hardened die forged special steel with counter weights |
| 4. Piston and rings | Heat resistance aluminum alloy
Two compression rings, chrome plated
One oil ring, chrome plated with coil expander |
| 5. Camshaft | Induction hardened carbon steel |
| 6. Valves | Heat resistance steel |

- EQUIPMENT

- ENGINE

- | | |
|--------------------------|--|
| 1. Flywheel housing | SAE No. 3 |
| 2. Flywheel | SAE 11½ |
| 3. Fuel injection pump | BOSCH "A" type with all speed governor |
| 4. Fuel filter | Paper element type |
| 5. Water separator | Equipped |
| 6. Lube oil pump | Full forced pressure feed by gear pump |
| 7. Lube oil filter | Paper element type (Full flow) |
| 8. Lube oil cooler | Multi plate type, Fresh water cooled |
| 9. Fresh water pump | Forced-circulation by volute pump |
| 10. Raw water pump | Self priming, Rubber impeller type |
| 11. Intake manifold | Inlet position at rear, with air cleaner |
| 12. Exhaust manifold | Fresh water-cooled exhaust manifold, integrated heat exchanger with expansion tank |
| 13. Starter | 12V, 2.5 KW |
| 14. Alternator | 12V, 50A, with built-in voltage regulator |
| 15. Engine stop solenoid | Equipped |
| 16. Emergency stop relay | Equipped |
| 17. Starter block relay | Equipped |
| 18. Glow plug | Equipped |
| 19. Rigid mount bracket | Equipped |
| 20. Exhaust riser | Cooled by raw water |

- INSTRUMENT PANEL

1. Battery switch
2. Starter switch with key
3. Instrument panel lamp switch
4. Tachometer (with hourmeter and trip meter)
5. Coolant temperature gauge
6. Oil pressure gauge
7. Fuel gauge
8. Volt meter
9. Pre-heater indicator lamp
10. Coolant temperature warning lamp
11. Charge warning lamp
12. Oil pressure warning lamp

SPECIFICATIONS
DIESEL ENGINE FOR MARINE USE

HINO W04C-T

3.839 liters, 4-cycle,
4-cyl., water-cooled,
turbocharged

• **ENGINE DESCRIPTION**

- | | |
|--|---|
| 1. Max. output, pleasure craft | 112 kW (150 HP)/3,000 rpm |
| 2. Max. output, work boat
(light duty) | 93 kW (125 HP)/3,000 rpm |
| 3. Type | Diesel, 4-cycle, 4-cyl., in-line, over-head valve, water-cooled |
| 4. Aspiration | Turbocharged |
| 5. Combustion system | Direct injection |
| 6. Cylinder
Bore x Stroke | 104 x 113 mm (4.09 x 4.45 in.) |
| 7. Piston displacement | 3.839 liter (234.2 cu.in.) |
| 8. Compression ratio | 17.9 |
| 9. Direction of rotation | Counter-clockwise viewed from flywheel |
| 10. Dimensions with marine
gear (L x W x H) | Approx. 1,134 x 661 x 790 mm
(44.6 x 26.0 x 31.1 in.) |
| 11. Dry weight with marine
gear | Approx. 465 kg (1,025 lb) |

• **FEATURES**

- | | |
|---------------------|--|
| 1. Cylinder block | Mono block cast iron with replaceable dry liner |
| 2. Cylinder head | Single piece cast iron |
| 3. Crankshaft | Induction hardened die forged special steel with counter weights |
| 4. Piston and rings | Heat resistance aluminum alloy
Two compression rings, chrome plated
One oil ring, chrome plated with coil expander |
| 5. Camshaft | Induction hardened carbon steel |
| 6. Valves | Heat resistance steel |

- EQUIPMENT

- ENGINE

- | | |
|--------------------------|--|
| 1. Flywheel housing | SAE No. 3 |
| 2. Flywheel | SAE 11½ |
| 3. Fuel injection pump | BOSCH "A" type with all speed governor |
| 4. Fuel filter | Paper element type |
| 5. Water separator | Equipped |
| 6. Lube oil pump | Full forced pressure feed by gear pump |
| 7. Lube oil filter | Paper element type (Full flow) |
| 8. Lube oil cooler | Multi plate type, Fresh water cooled |
| 9. Fresh water pump | Forced-circulation by volute pump |
| 10. Raw water pump | Self priming, Rubber impeller type |
| 11. Intake manifold | Inlet position at rear |
| 12. Exhaust manifold | Fresh water-cooled exhaust manifold, integrated heat exchanger with expansion tank |
| 13. Turbocharger | Cooled by fresh water, with air cleaner |
| 14. Starter | 12V, 2.5 KW |
| 15. Alternator | 12V, 50A, with built-in voltage regulator |
| 16. Engine stop solenoid | Equipped |
| 17. Emergency stop relay | Equipped |
| 18. Starter block relay | Equipped |
| 19. Grow plug | Equipped |
| 20. Rigid mount bracket | Equipped |
| 21. Exhaust riser | Cooled by raw water |
| 22. Marine gear | Equipped |

- INSTRUMENT PANEL

1. Battery switch
2. Starter switch with key
3. Instrument panel lamp switch
4. Tachometer (with hourmeter and trip meter)
5. Coolant temperature gauge
6. Oil pressure gauge
7. Fuel gauge
8. Volt meter
9. Pre-heater indicator lamp
10. Coolant temperature warning lamp
11. Charge warning lamp
12. Oil pressure warning lamp

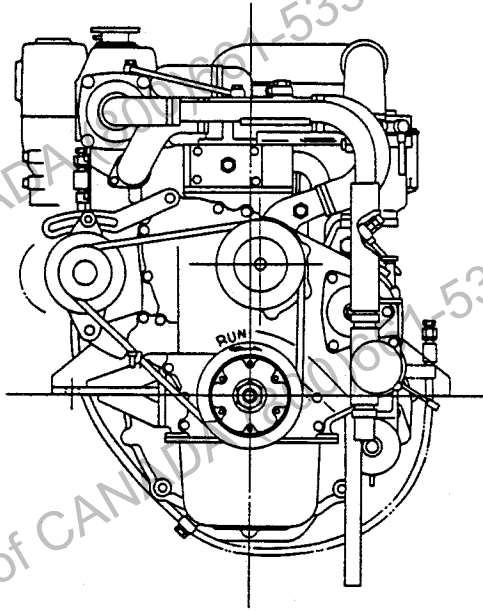

FRONT VIEW

F226

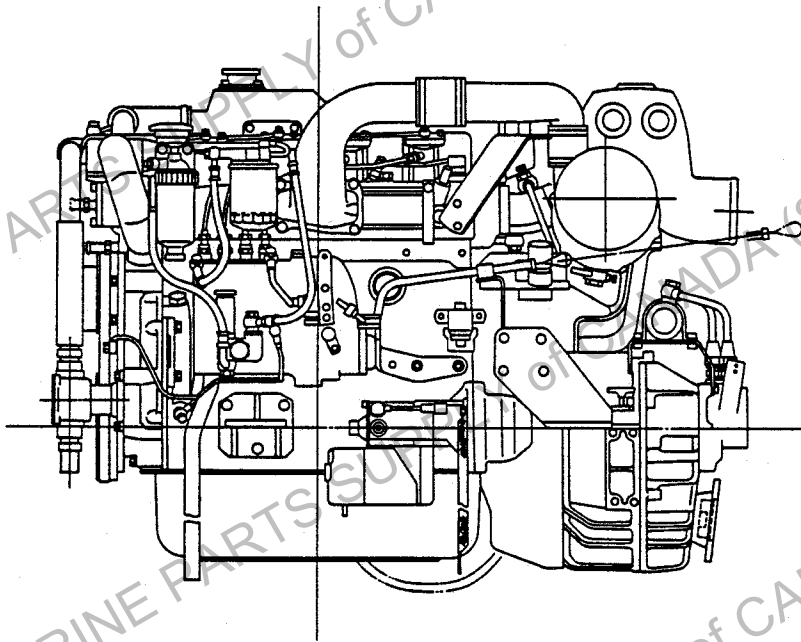

LEFT SIDE VIEW

F227

NOTE: These specifications are subject to change without notice.

Hino HINO MOTORS, LTD.

TOKYO, JAPAN

**Marine
Parts
Supply
of Canada**
1520 Stewart Ave
Nanaimo, B.C.
V9S 4E1
ph (800) 661-5353
fax (250) 754-9471

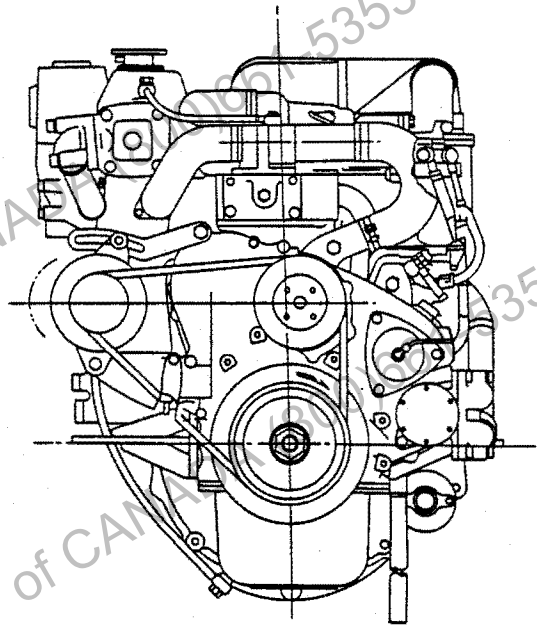

FRONT VIEW

F228

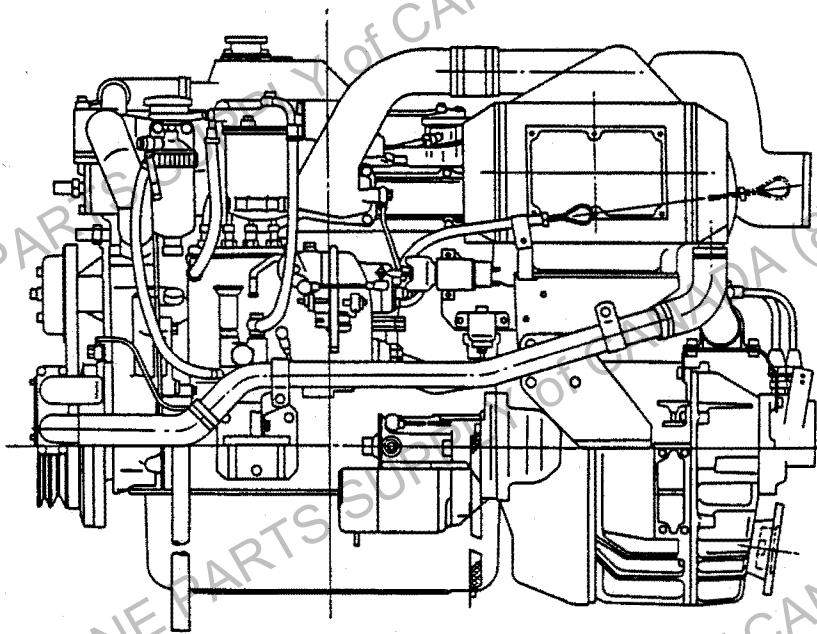

LEFT SIDE VIEW

F229

NOTE: These specifications are subject to change without notice.

Hino HINO MOTORS, LTD.

TOKYO, JAPAN

**Marine
Parts
Supply
of Canada**
1520 Stewart Ave
Nanaimo, B.C.
V9S 4E1
ph (800) 661-5353
fax (250) 754-9471

TIGHTENING TORQUE OF STANDARD BOLT

Unit: kg-cm (lb.ft)

Bolt identification	Tightening conditions	Bolt diameter (mm)										
		4	6	8	10	12	14	16	18	20	22	24
4	Even tightening area. Bolt nut, coating, naked bolt, lubricant, etc. Optimum conditions.	10 - 15 (0.8 - 1.0)	36 - 53 (2.7 - 3.8)	88 - 128 (7 - 9)	174 - 255 (13 - 18)	304 - 445 (22 - 32)	486 - 712 (36 - 51)	758 - 1,110 (55 - 80)	1,040 - 1,530 (76 - 110)	1,480 - 2,170 (108 - 156)	2,030 - 2,980 (147 - 215)	2,560 - 3,750 (186 - 271)
	Cast iron or aluminum tightening surface. Washers. Medium conditions.	14 - 20 (1.1 - 1.4)	48 - 71 (3.5 - 5.1)	117 - 172 (9 - 12)	232 - 340 (17 - 24)	405 - 592 (30 - 42)	647 - 950 (47 - 68)	1,010 - 1,480 (74 - 107)	1,390 - 2,040 (101 - 147)	1,970 - 2,900 (143 - 209)	2,700 - 3,970 (196 - 287)	3,410 - 5,000 (247 - 361)
	Tightening area having black coarse surface. Rusty. Naked bolt or lubricant unavailable. Poor tightening conditions.	17 - 25 (1.3 - 1.8)	60 - 88 (4.4 - 6.3)	146 - 214 (11 - 15)	290 - 425 (21 - 30)	506 - 742 (37 - 53)	809 - 1,180 (59 - 85)	1,260 - 1,850 (92 - 133)	1,740 - 2,540 (126 - 183)	2,460 - 3,620 (178 - 261)	3,380 - 4,950 (245 - 358)	4,260 - 6,250 (309 - 452)
6	Even tightening area. Bolt nut, coating, naked bolt, lubricant, etc. Optimum conditions.	16 - 24 (1.2 - 1.7)	58 - 83 (4.2 - 6.0)	138 - 201 (10 - 14)	273 - 400 (20 - 28)	477 - 700 (35 - 50)	764 - 1,120 (56 - 81)	1,190 - 1,750 (87 - 126)	1,640 - 2,400 (119 - 173)	2,320 - 3,410 (168 - 246)	3,180 - 4,680 (231 - 338)	4,020 - 5,360 (291 - 387)
	Cast iron or aluminum tightening surface. Washers. Medium conditions.	22 - 32 (1.6 - 2.3)	75 - 110 (5.5 - 7.9)	183 - 270 (14 - 19)	364 - 533 (27 - 38)	636 - 932 (47 - 67)	1,020 - 1,500 (74 - 108)	1,590 - 2,330 (116 - 168)	2,180 - 3,200 (158 - 231)	3,100 - 4,550 (225 - 329)	4,250 - 6,210 (308 - 449)	5,360 - 7,850 (388 - 567)
	Tightening area having black coarse surface. Rusty. Naked bolt or lubricant unavailable. Poor tightening conditions.	27 - 40 (2.0 - 2.8)	94 - 138 (6.8 - 9.9)	229 - 336 (17 - 24)	455 - 667 (33 - 48)	795 - 1,165 (58 - 84)	1,270 - 1,870 (92 - 135)	1,990 - 2,920 (144 - 211)	2,730 - 4,000 (198 - 289)	3,870 - 5,680 (280 - 410)	5,310 - 7,800 (385 - 564)	6,700 - 9,850 (485 - 712)
8	Even tightening area. Bolt nut, coating, naked bolt, lubricant, etc. Optimum conditions.	24 - 32 (1.8 - 2.3)	82 - 110 (6.0 - 7.9)	200 - 267 (15 - 19)	397 - 574 (29 - 41)	694 - 925 (51 - 66)	1,010 - 1,480 (74 - 107)	1,730 - 2,310 (126 - 167)	2,380 - 3,170 (173 - 229)	3,380 - 4,510 (244 - 326)	4,630 - 6,170 (335 - 446)	5,850 - 7,790 (424 - 563)
	Cast iron or aluminum tightening surface. Washers. Medium conditions.	32 - 42 (2.4 - 3.0)	110 - 146 (8.0 - 10.5)	267 - 356 (19 - 25)	529 - 706 (39 - 51)	925 - 1,230 (67 - 88)	1,480 - 1,970 (108 - 142)	2,310 - 3,080 (168 - 222)	3,170 - 4,230 (230 - 305)	4,510 - 6,010 (327 - 434)	6,170 - 8,230 (447 - 595)	7,790 - 10,390 (564 - 751)
	Tightening area having black coarse surface. Rusty. Naked bolt or lubricant unavailable. Poor tightening conditions.	40 - 53 (2.9 - 3.8)	137 - 183 (10.0 - 13.2)	334 - 445 (25 - 32)	662 - 882 (48 - 63)	1,160 - 1,540 (84 - 111)	1,850 - 2,470 (134 - 178)	2,890 - 3,850 (210 - 278)	3,970 - 5,290 (288 - 382)	5,640 - 7,510 (408 - 543)	7,720 - 10,290 (559 - 744)	9,740 - 12,990 (705 - 939)

NOTE: The torque values given in this table should be applied where bolt torque is not specified.



**Marine
Parts
Supply
of Canada**
1520 Stewart Ave
Nanaimo, B.C.
V9S 4E1
ph (800) 661-5353
fax (250) 754-9471



RECOMMENDED LUBRICANTS FOR ALL HINO ENGINE

HINO MOTORS, LTD.
OVERSEAS OPERATIONS
SERVICE DIV.
TOKYO, JAPAN

LUBRICANTS	POSITIONS	ATMOSPHERIC TEMP.	S.A.E. NO.	BP	CALTEX	CASTROL	ESSO	GULF	MOBIL	SHELL	TOTAL
ENGINE OIL (A P.I. CD) Previous Classification (A P.I. DS) (MIL-L-2104C) (MIL-L-45199B)	Cylinder Block Injection Pump Air Cleaner	Above 32°C (90°F)	40	Vanellus C-3 40	RPM DELO 400 Oil SAE 40 or 15W/40 RPM DELO 300 Oil SAE 40	Castrol or Deusol CRD 40, Turbomax Castrol or Deusol RX Super 40, 15W/40	Essolube D-3 40, XD-3 40	Gulf Super Duty Motor Oil 40, 15W-40	Mobil Delvac 1340 Mobil Delvac Super 15W-40	Myrina Oil 40, 20W-40, 15W-40 Rimula X Oil 40 Rimula CT 40	TOTAL Rubia S 40 TOTAL Rubia TM 15W40
		32° 0'C (90° 32'F)	30	Vanellus C-3 30	RPM DELO 400 Oil SAE 30 or 15W/40 RPM DELO 300 Oil SAE 30	Castrol or Deusol CRD 30 Castrol or Deusol RX Super 30, 15W/40	Essolube D-3 30, XD-3 30	Gulf Super Duty Motor Oil 30, 15W-40	Mobil Delvac 1330 Mobil Delvac Super 15W-40	Myrina Oil 30, 20W-40, 15W-40 Rimula X Oil 30, 10W-30 Rimula CT30	TOTAL Rubia S 30 TOTAL Rubia TM 15W40
		0° 12'C (32° 10'F)	20	Vanellus C-3 20W	RPM DELO 400 Oil SAE 20/20W, 15W/40 RPM DELO 300 Oil SAE 20/20W	Castrol or Deusol CRD 20W/20 Castrol or Deusol RX Super 20W/20, 15W/40	Essolube D-3 20W, XD-3 15W-40	Gulf Super Duty Motor Oil 20, 15W-40	Mobil Delvac 1310 Mobil Delvac Super 15W-40	Myrina Oil 20, 20W-40, 15W-40 Rimula X Oil 20 Rimula CT20	TOTAL Rubia S 20 TOTAL Rubia TM 15W40
ENGINE OIL (A P.I. CC) Previous Classification (A P.I. DM) (MIL-L-46152) (MIL-L-2104B)		Above 32°C (90°F)	40	Vanellus M 40	RPM DELO 200 Oil SAE 40 RPM DELO 100 Oil SAE 40	Castrol or Deusol CRX 40 Castrol or Deusol RX Super 40, 15W/40	Essolube HDX 40, HDX Plus 40	Gulflube Motor Oil XHD 40, 15W-40	Mobil Delvac 1240 Mobil Delvac 1140	Rotella TX40, 20W-50 Rotella SX Oil 40, 20W-40	TOTAL Rubia H 40
		32° 0'C (90° 32'F)	30	Vanellus M 30	RPM DELO 200 Oil SAE 30 RPM DELO 100 Oil SAE 30	Castrol or Deusol CRX 30 Castrol or Deusol RX Super 30, 15W/40	Essolube HDX 30, HDX Plus 30	Gulflube Motor Oil XHD 30, 15W-40	Mobil Delvac 1230 Mobil Delvac 1130	Rotella TX30, 20W-50 Rotella SX Oil 30, 20W-40	TOTAL Rubia H 30
		0° 12'C (32° 10'F)	20	Vanellus M 20W	RPM DELO 200 Oil SAE 20/20W RPM DELO 100 Oil SAE 20/20W	Castrol or Deusol CRX 20W/20 Castrol or Deusol RX Super 20W/20, 15W-40	Essolube HDX 20, HDX Plus 20W-20	Gulflube Motor Oil XHD 20, 15W-40	Mobil Delvac 1220 Mobil Delvac 1120	Rotella TX20, 20W-50 Rotella SX Oil 20/20W, 20W-40	TOTAL Rubia H 20
COOLANT PUMP BEARING GREASE (MIL-G-10924B)	Coolant Pump Bearing			Energrease L-2	Marfak Multipurpose 2 or Marfak All Purpose 2	Castrol LM Grease	Esso Multipurpose Grease	Gulflax Poly	Mobilgrease MP. 77, MS	Retinas A Alvania Grease R2	TOTAL MULTIS 2
STARTER GREASE	Bushing, Clutch, Drive Shaft, Pinion Shift Lever & Reduction Gear				Molytex Grease EP2				Mobilgrease 29	Aero Shell Grease 17	
GENERATOR & STARTER BEARING GREASE	Generator Bearing Starter Bearing			Energrease LT 2	RPM Grease SRI 2				Mobilgrease 28	Aero Shell Grease 7	
INJECTION PUMP TIMER GREASE (MIL-G-10924B)	Injection Pump Timer			Energrease L-2	Marfak Multipurpose 2 or Marfak All Purpose 2	Castrol LM Grease	Esso Multipurpose Grease	Gulflax Poly	Mobilgrease MP. 77, MS	Retinas A Alvania Grease R2	TOTAL Multis EP 1
ANTI FREEZE (MIL-H-5559A)	Engine, Radiator			Anti Frost	AF Engine Coolant	Castrol Anti-Freeze Castrol Long Life Coolant	Esso Anti Freeze Coolant	Cruise Master Antifreeze And Summer Coolant	Mobil Permazone	Shellzonal(U.S.A.) Glycoshell Plus (European Countries) Shellsafe Anti-Freeze P281 Coolguard	TOTAL ANTIGEL

Note: Lubricants were amended according to new classification by A. P. I. (American Petroleum Institute)

'82-12-200 (R.S.D.H.)

(K.P.)

GENERAL INTRODUCTION

Marine Parts Supply of Canada
1520 Stewart Ave
Nanaimo, B.C.
V9S 4E1
ph (800) 661-5353
fax (250) 754-9471

DATA AND SPECIFICATIONS

Model	W04D	W04C-T	W04C-T1
Type	Diesel, 4-cycle, vertical, 4 cylinder, in-line, overhead valve, water- cooled	←	←
Aspiration	Natural aspirate	Turbo charged	Turbocharged and intercooled
Combustion system	Direct injection	←	←
Bore and stroke	104 x 118 mm (4.09 x 4.65 in)	104 x 113 mm (4.09 x 4.45 in)	←
Piston displacement	4.009 liters (244.6 cu.in)	3.839 liters (234.2 cu.in)	←
Compression ratio	17.9	←	16.5
Firing order	1-3-4-2 (A number of a cylinder is to be counted in order from the pulley side)	←	←
Direction of rotation	Counter-clockwise viewed from flywheel	←	←
Maximum revolution (at full load) .	3,000 rpm	←	←
Idling revolution	775-825 rpm	←	750-800 rpm
Dry weight with marine transmission.	Approx. 430 kg (948 lb)	Approx. 465 kg (1,025 lb)	Approx. 520 kg (1,146 lb)
Valve timing (flywheel travel),			
Intake opens	16° before T.D.C.	←	←
Intake closes	40° after B.D.C.	←	←
Exhaust opens	55° before B.D.C.	←	←
Exhaust closed	13° after T.D.C.	←	←
Valve clearance (when cold),			
Intake	0.30 mm (0.0118 in)	←	0.35 mm (0.0138 in)
Exhaust	0.40 mm (0.0157 in)	0.45 mm (0.0177 in)	0.50 mm (0.0197 in)
Injection nozzle opening pressure .	220 kg/cm ² (3,129 lb/sq.in)	←	←
Injection timing	14° before T.D.C. for No.1 cylinder on compression stroke	17° before T.D.C. for No.1 cylinder on compression stroke	←

Model W04D

PERFORMANCE CURVE

PLEASURE CRAFT RATING

LIGHT DUTY RATING

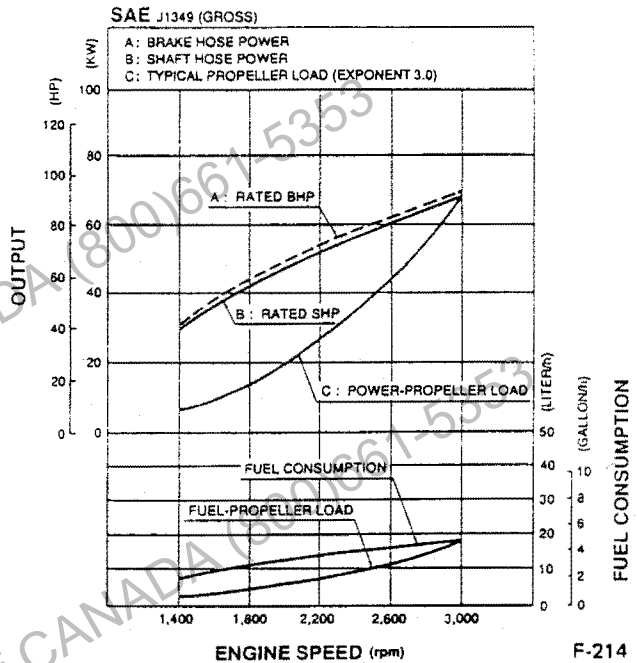
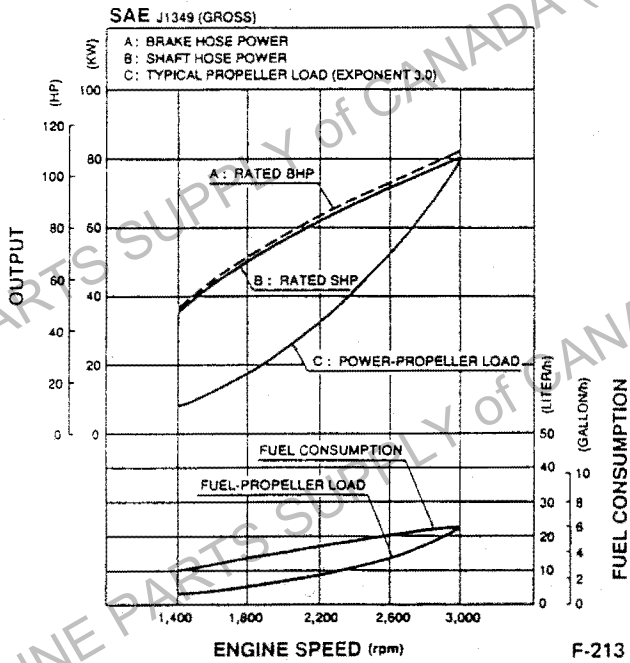

NOTE:

Engine performance at SAE standard J1349 conditions of 90m (300ft) altitude (100 kPa [29.61 in.Hg] barometric pressure), 25°C (77°F) air intake temperature, and 1 kPa (0.30 in.Hg) water vapor pressure with No.2 diesel fuel will be within 5% of that shown at the time of engine shipment. Actual performance may vary with different ambient conditions.

Model W04C-T

PERFORMANCE CURVE

PLEASURE CRAFT RATING

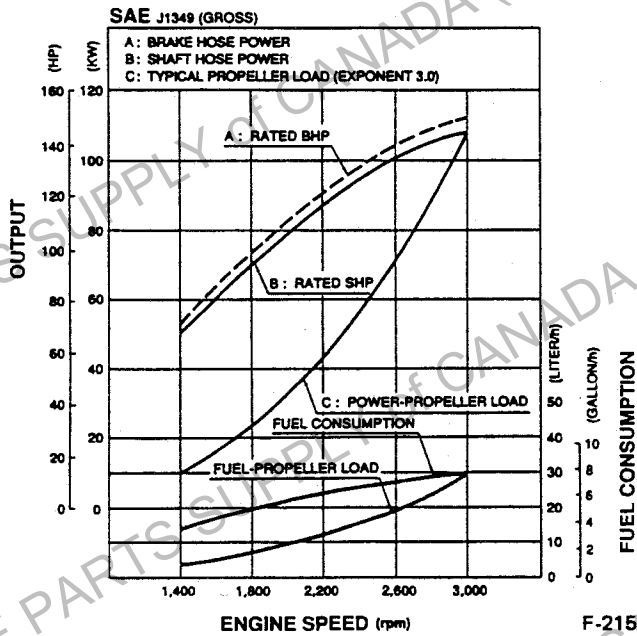

LIGHT DUTY RATING

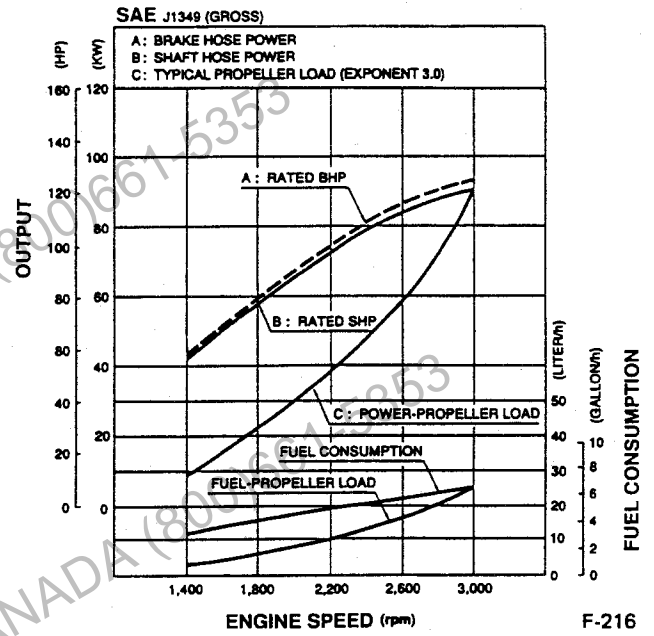

F-215

F-216

NOTE:

Engine performance at SAE standard J1349 conditions of 90m (300ft) altitude (100 kPa [29.61 in.Hg] barometric pressure), 25°C (77°F) air intake temperature, and 1 kPa (0.30 in.Hg) water vapor pressure with No.2 diesel fuel will be within 5% of that shown at the time of engine shipment. Actual performance may vary with different ambient conditions.

DESCRIPTION

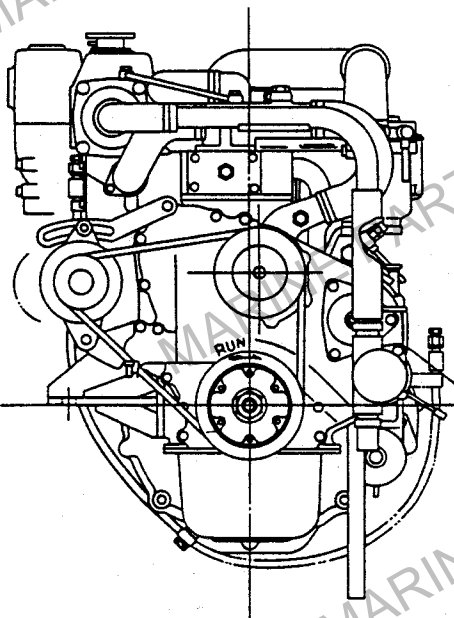

DHF-226

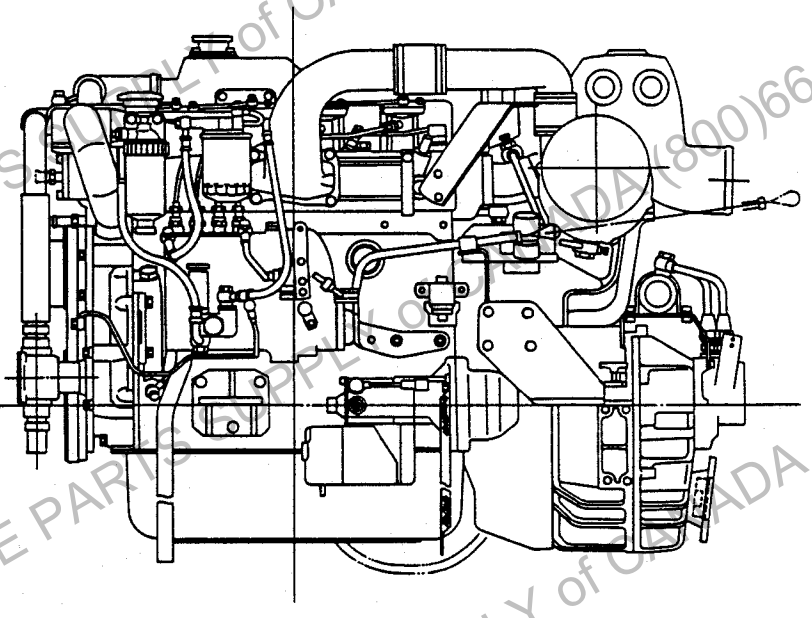

DHF-227

Model W04C-TI

PERFORMANCE CURVE

PLEASURE CRAFT RATING

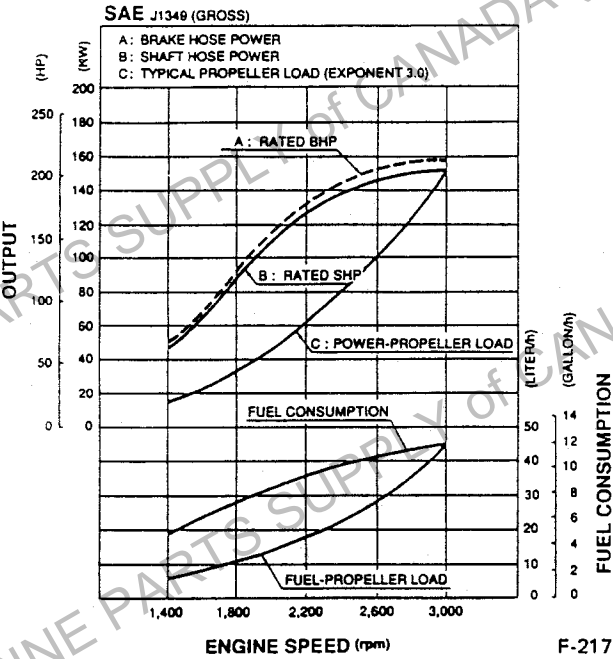

LIGHT DUTY RATING

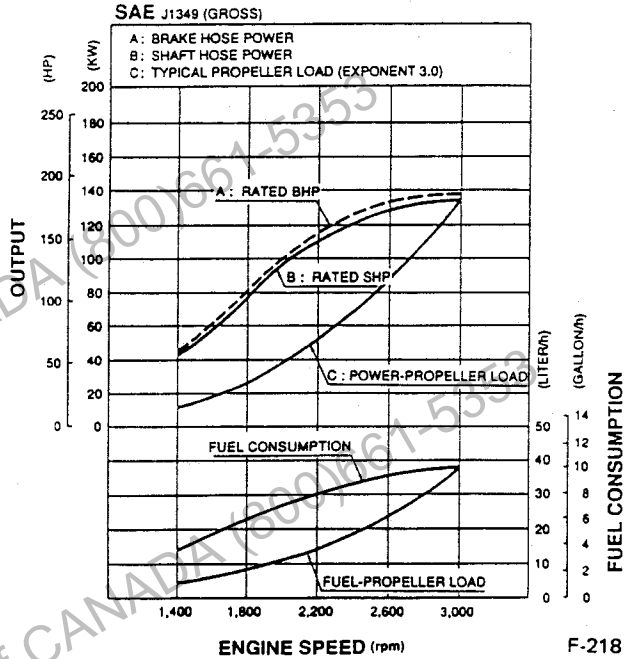

NOTE:

Engine performance at SAE standard J1349 conditions of 90m (300ft) altitude (100 kPa [29.61 in.Hg] barometric pressure), 25°C (77°F) air intake temperature, and 1 kPa (0.30 in.Hg) water vapor pressure with No.2 diesel fuel will be within 5% of that shown at the time of engine shipment. Actual performance may vary with different ambient conditions.

DESCRIPTION

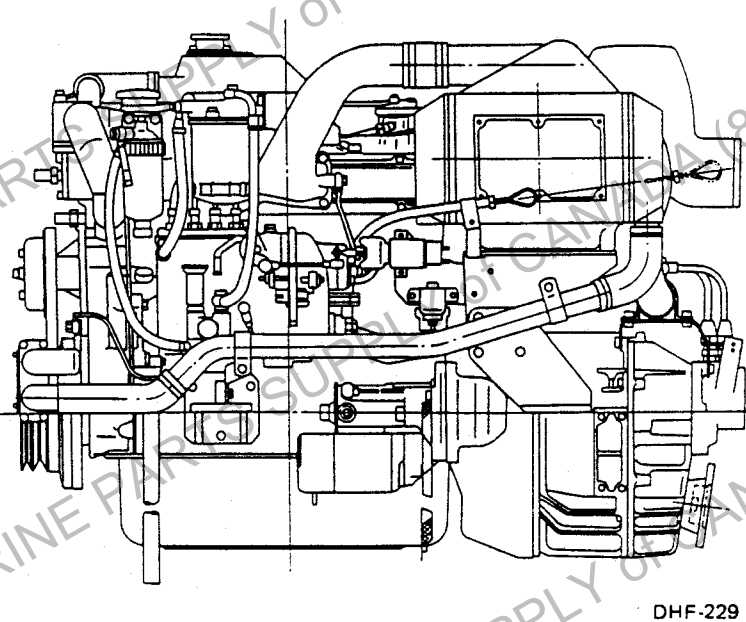
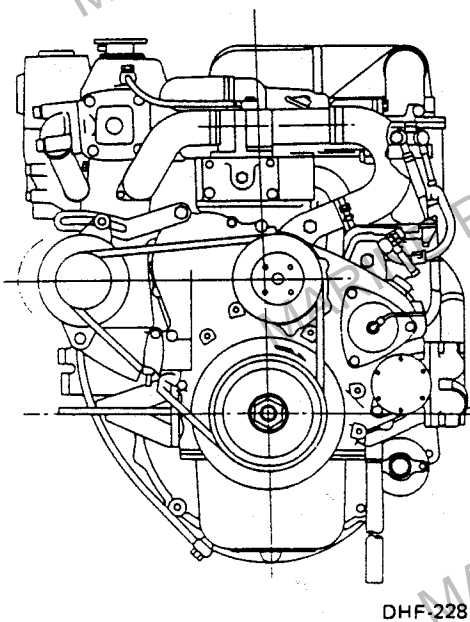

TROUBLESHOOTING

Symptom

Possible cause

Remedy/Prevention

Engine overheating

Coolant

- Insufficient coolant Add coolant.
- Defective thermostat Replace the thermostat.
- Overflow of coolant due to leakage of exhaust into cooling system Repair.
- Coolant leakage from cylinder head gasket Replace gasket.
- Defective coolant pump Repair or replace.

Radiator

- Clogged with rust and scale Clean radiator.
- Clogged with iron oxide due to leakage of exhaust into cooling system Clean coolant passage and correct exhaust leakage.
- Clogged radiator core due to mud or other debris Clean radiator.
- Defective radiator cap pressure valve Replace radiator cap.

Abnormal combustion

- Incorrect injection timing Adjust injection timing.
- Reduced injection pressure Adjust injection pressure.
- Poor fuel Use good quality fuel.
- Poor nozzle spray Adjust or replace nozzle.
- Unsatisfactory automatic timer advance angle Repair or replace timer.

Other problems

- Defective or deteriorated engine oil Change engine oil.
- Unsatisfactory operation of oil pump Replace or repair.
- Insufficient oil Add oil.
- Brake drag Repair or adjust.

Excessive oil consumption

Pistons, cylinder liners, and piston rings

- Wear of piston ring and cylinder liner Replace piston rings and cylinder liner.
- Worn, sticking or broken piston rings Replace piston rings and cylinder liner.
- Insufficient tension on piston rings Replace piston rings and cylinder liner.
- Unsatisfactory break-in of piston rings Replace piston rings and cylinder liner.
- Unsuitable oil (viscosity too low) Change oil as required and replace piston rings and cylinder liners.
- Incorrectly fitted piston rings (upside down) Replace piston rings.
- Gaps of piston rings in line with each other Reassemble piston rings.

Symptom	Possible cause	Remedy/Prevention
Excessive oil consumption	Valve and valve guides	
	• Worn valve stem	Replace valve and valve guide.
	• Worn valve guide	Replace valve guide.
	• Incorrectly fitted valve stem seal	Replace the stem seal.
	• Excessive lubricant on rocker arm	Check clearance of rocker arm and shaft.
	Excess oil feed	
	• Defective oil level gauge	Replace oil level gauge.
	• Oil level too high	Drain excess oil.
	Other problems	
	• Overcooled engine (low temperature wear)	Warm up engine before moving vehicle. Check cooling system.
• Oil leakage from miscellaneous parts	Repair.	
Piston seizure	Operation	
	• Abrupt stoppage of engine after running at highspeed	Operate engine properly.
	• Hill climbing using unsuitable gear	Select suitable gear.
	Oil	
	• Insufficient oil	Add oil.
	• Dirty oil	Change oil.
	• Poor quality oil	Replace with proper engine oil.
	• High oil temperature	Repair.
	• Low oil pressure	Repair.
	• Defective oil pump	Repair oil pump.
• Reduced performance due to worn oil pump	Replace oil pump.	
• Suction strainer sucking air	Add oil and/or repair strainer.	
Abnormal combustion	See Symptom: "Engine overheating."	
Coolant	See Symptom: "Engine overheating."	
Lack of power	Injection pump	Refer to CHAPTER IP, FUEL INJECTION PUMP.
	Intake	
	• Clogged air cleaner	Clean element or replace element.
	Overheating	See Symptom: "Engine overheating."

Symptom

Possible cause

Remedy/Prevention

Lack of power

Fuel and nozzle

- Poor nozzle spray Adjust or replace injection nozzle.
- Clogged nozzle with carbon Clean nozzle.
- Wear or seizure of nozzle Replace nozzle.
- Air in fuel system Repair and bleed air from fuel system.
- Clogged fuel filter Replace element.
- Use of poor fuel Use good quality fuel.

Abnormal combustion See Symptom: "Engine overheating."

Piston, cylinder liners, and piston rings See Symptom "Engine overheating."

Other problems

- Breakage of turbine or blower Replace the turbine or blower or turbocharger.

Difficulty starting engine

Electrical system

- Discharged battery Charge battery.
- Defective wiring in starter circuit Repair wiring of starter.
- Loose or open-circuit battery cable Tighten battery terminal connections or replace battery cable.
- Breakdown of starter Replace starter.
- Break of glow plug or intake air heater (If so equipped) Replace

Injection pump Refer to CHAPTER IP, FUEL INJECTION PUMP.

Air cleaner

- Clogged element Clean the element or replace the element.

Fuel system

- No fuel in tank Supply fuel and bleed air from fuel system.
- Clogged fuel line Clean fuel line.
- Air sucked into fuel system through fuel line connections Tighten fuel line connections.
- Clogged fuel filter Replace element.
- Loose connection in high-pressure line Tighten sleeve nut of high pressure line.
- Water in fuel Drain and clean fuel system

Symptom	Possible cause	Remedy/Prevention
Difficulty starting engine	Nozzles	
	● Seized nozzle	Replace nozzle.
	● Broken or fatigued nozzle spring	Replace spring.
	Oil system	
	● Oil viscosity too high	Use proper viscosity oil, or install an oil immersion heater and warm up oil.
	Other problems	
	● Seized piston	Replace piston, piston rings, and liner.
	● Seized bearing	Replace bearing and/or crankshaft.
	● Reduced compression pressure	Overhaul engine.
	● Ring gear damaged or worn	Replace the ring gear and/or starter pinion.
● Improperly adjusted or broken accelerator cable	Adjust or replace the accelerator cable.	
Rough idling	Injection pump	Refer to CHAPTER IP, FUEL INJECTION PUMP.
	Nozzles	
	● Uneven injection pressure	Adjust.
	● Poor nozzle spray	Adjust or replace nozzle.
	● Carbon deposit on nozzle tip	Remove carbon.
	● Seized needle valve	Replace nozzle.
	Engine proper	
	● Improper valve clearance	Adjust valve clearance.
	● Improper contact of valve seat	Replace or repair valve and valve seat.
	● Idling speed too low	Adjust idling speed.
● Coolant temperature too low	Warm up engine.	
● Compression pressure of cylinders markedly different from one another	Overhaul engine.	
Leakage of exhaust	Cylinder head gasket	
	● Fatigued gasket (aging)	Replace gasket.
	● Damage	Replace gasket.
	● Improper installation	Replace gasket.

Symptom

Possible cause

Remedy/Prevention

Leakage of exhaust

Cylinder head bolts

- Loose bolts Tighten bolt.
- Elongated bolts Replace bolt.
- Improper tightening torque or Tighten properly.
tightening sequence

Cylinder block

- Cracking Replace cylinder block.
- Surface distortion Repair or replace.
- Fretting of cylinder liner insertion Replace cylinder liner or
portion (insufficient projection of cylinder liner)

Cylinder head

- Cracking Replace cylinder head.
- Surface distortion Repair or replace.

Cylinder liners

- Cracking Replace cylinder liner.
- Corrosion Replace cylinder liner.
- Insufficient projection of cylinder liner Replace cylinder liner.

Other problems

- Incorrect injection timing Adjust injection timing.

For MARINE ENGINE

Symptom

Possible cause

Remedy/Prevention

Engine overheating

Cooling system

- Defective sea water pump Repair or replace.
- Loose or slipping V-belt Adjust V-belt tension or replace.
- Closed sea water intake valve (Seacock) Open intake valve.
- Clogged sea water strainer Clean strainer.

Symptom	Possible cause	Remedy/Prevention
Engine overheating	Heat Exchanger	
	● Clogged with rust and scale	Clean heat exchanger.
	● Clogged with iron oxide due to leakage of exhaust into cooling system	Clean coolant passage and correct exhaust leakage.
	● Clogged or corroded heat exchanger due to mud or other debris	Clean or replace heat exchanger.
Excessive oil consumption	Cooling system	
	● Overcooled engine (low temperature wear)	Warm up engine before moving boat. Check cooling system.
Seawater discharge is not sufficient	Seawater pump	
	● Sucking air	Supply seawater and bleed air from cooling system.
	● Damaged impeller	Replace impeller.
Abnormal noise or vibration	Seawater pump	
	● Clogging of suction pipe and/or seawater strainer	Clean suction pipe and strainer.
	● Worn bearing	Replace bearing.
Bearing wears frequently	Seawater pump	
	● Foreign material in the pump	Repair or replace.
Damage of impeller	Seawater pump	
	● Incomplete mounting	Mount completely.
Damage of impeller	Seawater pump	
	● Too tight V-belt tension	Adjust V-belt tension.
	● When it has been operated for a long period	Replace impeller.
	● When it has been operated without seawater	Replace impeller.
	● When it has been operated at higher RPM	Replace impeller and operate at normal RPM.
	● Too high or low water temperature	Replace impeller and operate at normal temperature.
Damage of impeller	Seawater pump	
	● When it has not been operated for an extended period	Replace impeller.
	● Foreign material in the pump	Repair or replace.

ENGINE OVERHAUL CRITERIA

SPECIAL TOOL

Prior to starting an engine overhaul, it is necessary to have these special tools.

**COMPRESSION GAUGE
ADAPTOR (NOZZLE HOLDER)**

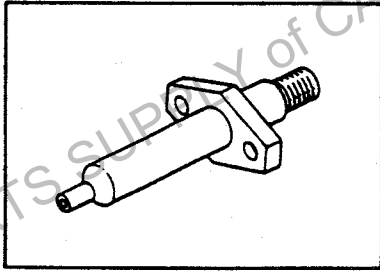

09408-1041

**COMPRESSION GAUGE
ADAPTOR (GLOW PLUG)**

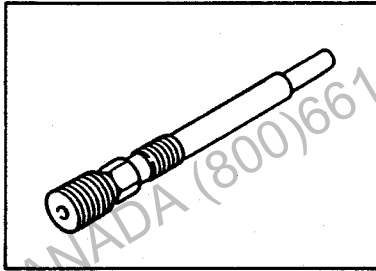

09552-1051

**COMPRESSION GAUGE
ADAPTOR**

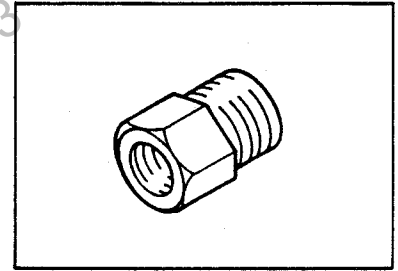

09552-1070

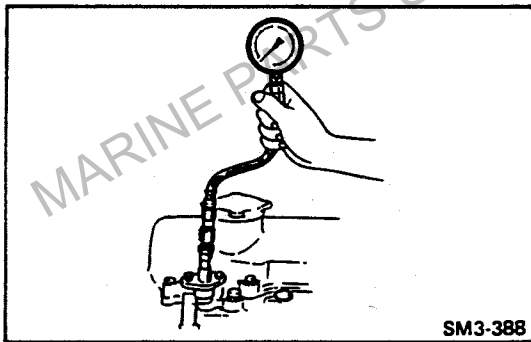

SM3-388

FACTORS WHICH DETERMINE WHEN AN ENGINE OVERHAUL IS NEEDED.

1. Lowered compression pressure
 - a. Before the measurement
 - a) Correct the valve clearance.
 - b) Warm up engine [Bring the coolant temperature to about 80°C (176°F)].
 - c) Charge the battery fully.
 - d) Remove the air cleaner.

- b. Measurement
 - 1) Measure at nozzle holder hole.
 - a) Remove the nozzle holders.
 - b) Install the gauge adapter in the nozzle holder hole.

Special Tool: Compression Gauge Adapter (09408-1041)
(09552-1070)

- 2) Measure at glow plug hole.
 - a) Remove the glow plug.
 - b) Install the gauge adapter in the glow plug hole.

Special Tool: Compression Gauge Adapter (09552-1051)
(09552-1070)

- c) Connect a compression gauge to the gauge adapter.
- d) Drive the engine with the starter and read the compression pressure.

NOTE: Do not continuously operate the starter for more than 15 seconds at a time.

- e) Measure the compression pressure for each cylinder. If the compression pressure is low, be sure to repeat the measuring.

NOTE: Be sure not to leak through sealing face.

Unit: kg/cm² (lb/sq.in)

Engine model	Compression pressure		Difference between each cylinder	Engine speed (rpm)
	Standard	Limit		
W04D W04C-T	33-36 (469-511)	25 (356)	Less than 3 (43)	270-310
W04C-TI	30-33 (427-469)	22 (313)		

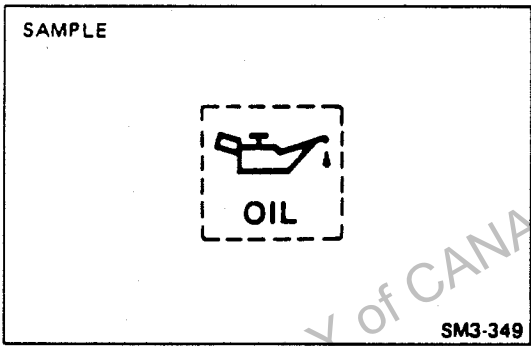

2. Decreased oil pressure
Check the oil pressure warning lamp when the oil and coolant temperature is hot [about 80°C (176°F)].
 - a. If the warning lamp is lighted, check the oil level.
 - b. Check oil deterioration.
If oil quality is poor, replace with a suitable grade oil.
 - c. Remove the oil pressure switch and install the oil pressure gauge.
 - d. Measure the oil pressure at coolant temperature 80°C (176°F) or more.

Standard oil pressure: 0.5–5.0 kg/cm² (7.11–71.10 lb/sq.in)
Service limit: Less than 0.5 kg/cm² (7.11 lb/sq.in)

S.A.E. GRADE	ATMOSPHERIC TEMPERATURE							°F
	-10	0	32	50	70	90	100	
	°C							
	-23	-18	0	10	21	32	39	°C
40								
30								
20W/20								
15W/40								

3. Other factors
 - a. The blow-by gas increases.
 - b. The engine does not start easily.
 - c. Engine output decreases.
 - d. Fuel consumption increases.
 - e. Engine makes greater noise.
 - f. Excessive oil consumption.

ENGINE MOVING PARTS

DESCRIPTION

Representative engine model W04C-T1

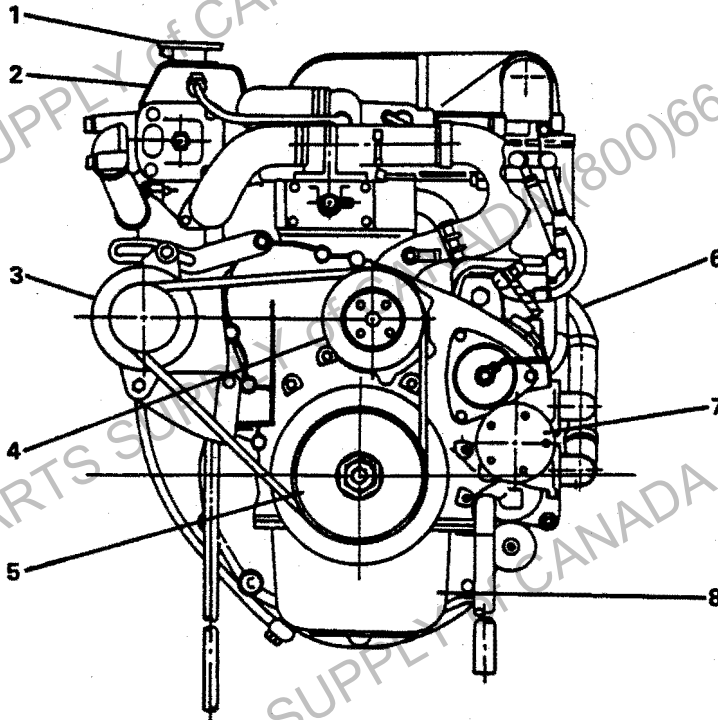

1. Heat exchanger cap
2. Heat exchanger
3. Generator
4. Engine coolant pump
5. Crankshaft pulley
6. Seawater pipe
7. Seawater pump
8. Oil pan
9. Water separator
10. Fuel filter
11. Engine stop solenoid
12. Oil level gauge
13. Intercooler
14. Fuel feed pump
15. Fuel injection pump
16. Starter

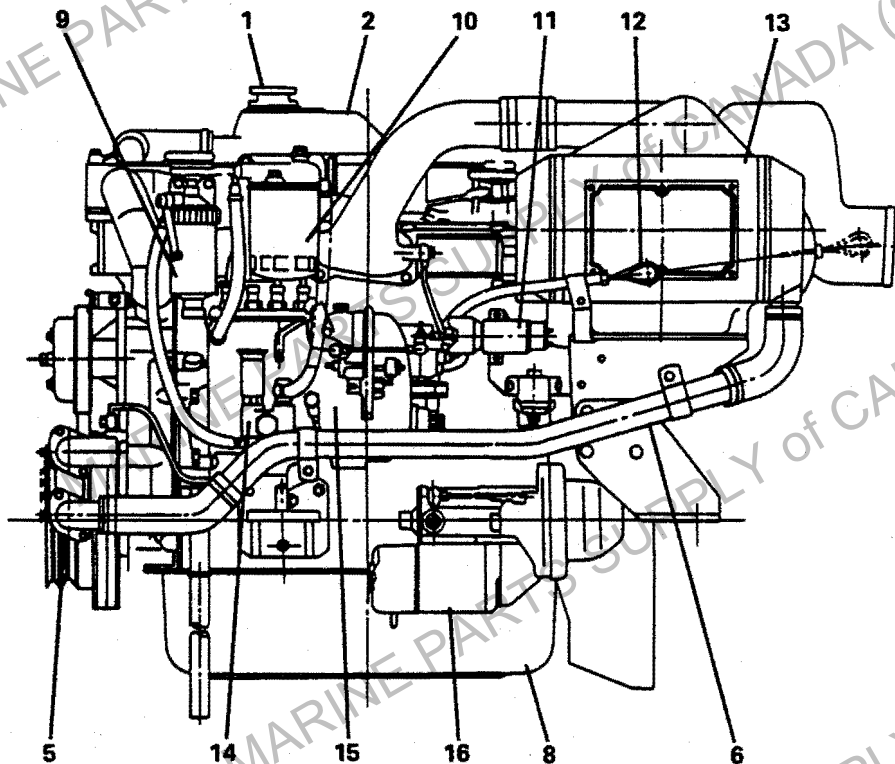

SPECIAL TOOL

Prior to starting an engine overhaul, it is necessary to have the following.

SLIDING HAMMER

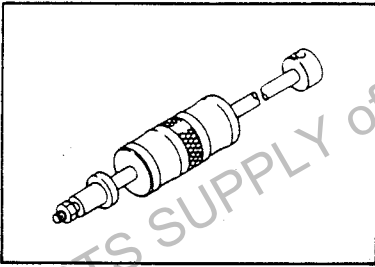

09420-1442

**ADAPTOR
(USED WITH 09420-1442)**

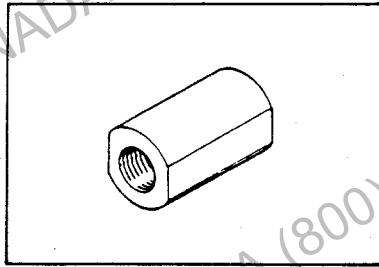

09462-1370 for model W04D

**ADAPTOR
(USED WITH 09420-1442)**

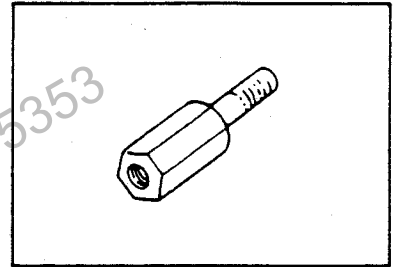

09462-1130 for models W04C-T and W04C-TI

CYLINDER HEAD BOLT WRENCH

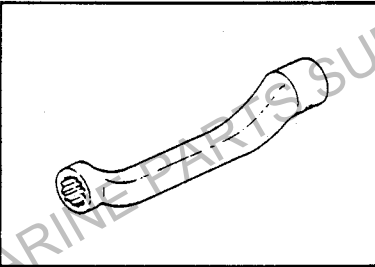

09411-1260

**EYE BOLT
(USED WITH 09470-1022)**

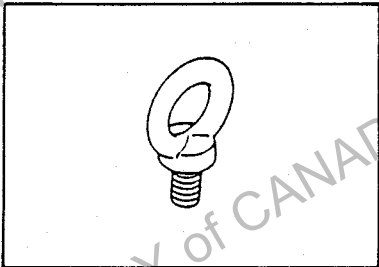

09433-1070

WIRE

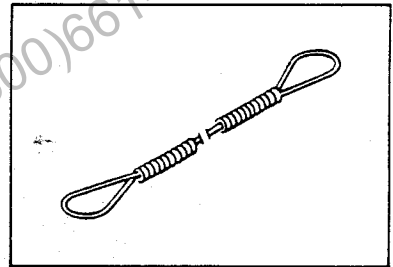

09491-1010

VALVE SPRING PRESS

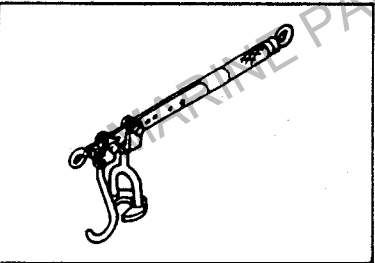

09470-1022

VALVE LAPPING TOOL

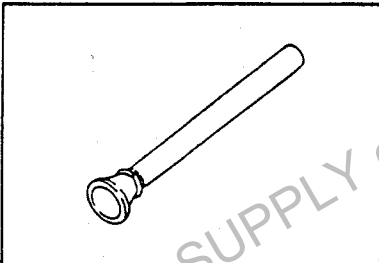

09431-1010

VALVE STEM SEAL PRESS

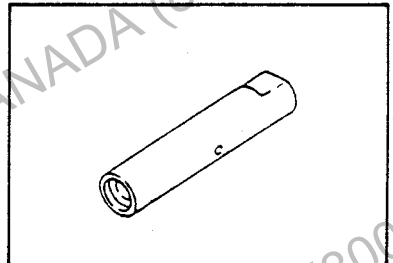

09472-1650

**CRANKSHAFT PULLEY
PULLER**

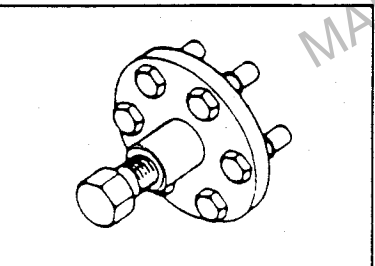

09420-1500

TIMER SETTING TOOL

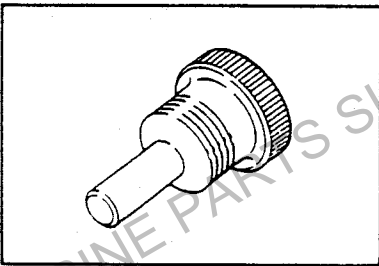

09512-2090 for model W04D
09512-2100 for models W04C-T
and W04C-TI

IDLER GEAR SHAFT PULLER

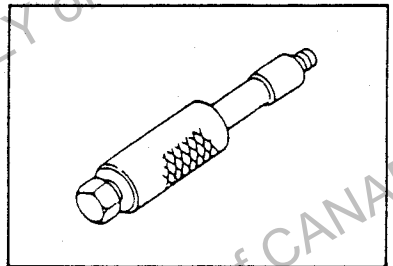

09420-1100

TIMING GEAR COVER OIL SEAL PRESS

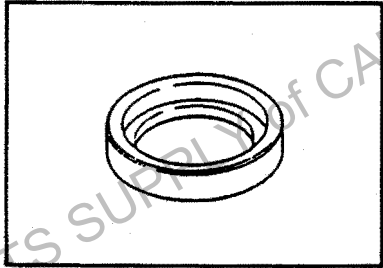

09482-1530

PISTON RING EXPANDER

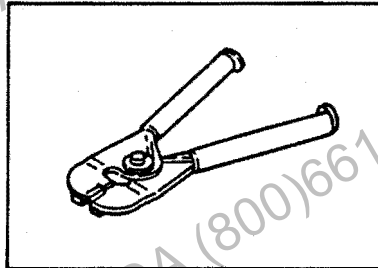

09442-1180

CYLINDER LINER PULLER

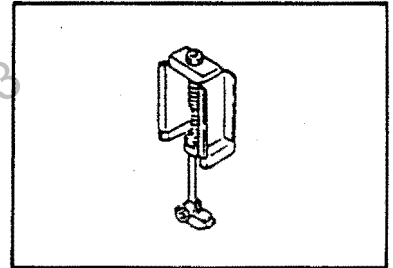

09420-1460

CYLINDER LINER GUIDE

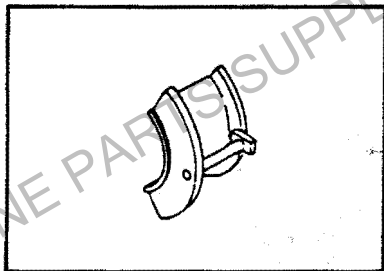

09480-1120

GUIDE

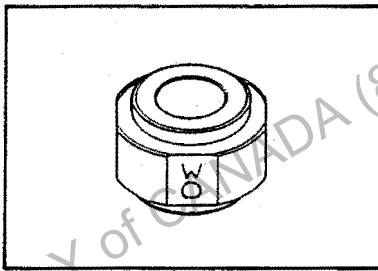

09481-1130

PRESS SUB ASSEMBLY

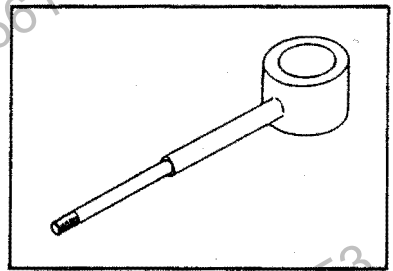

09402-1450

WING NUT

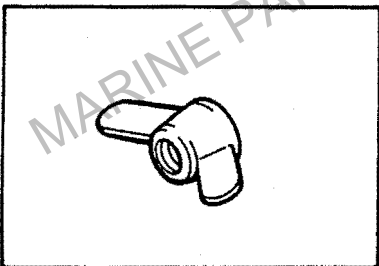

9233-10360

SPINDLE

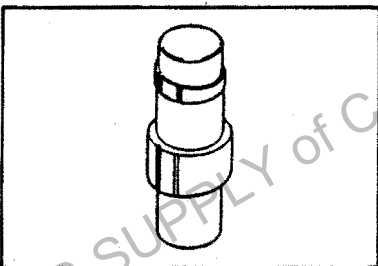

09402-1470 for models W04C-T and W04C-TI

SPINDLE

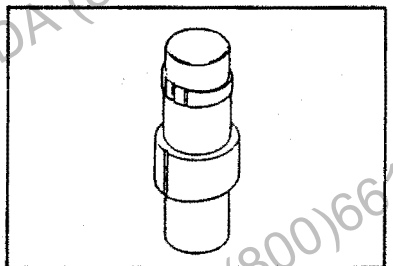

09402-1460 for model W04D

GUIDE

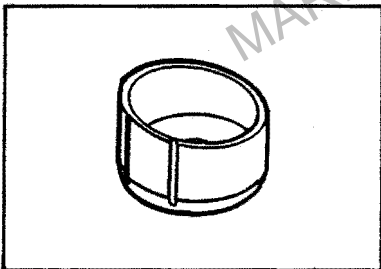

09481-1140 for models W04C-T and W04C-TI

GUIDE

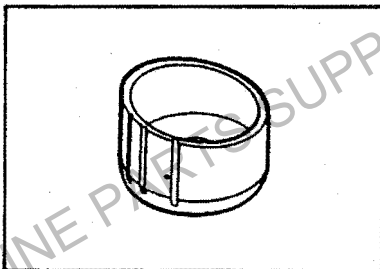

09481-1120 for model W04D

BOLT

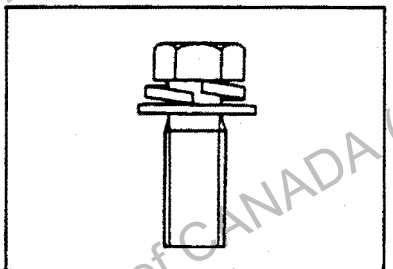

9191-08252

PISTON RING HOLDER

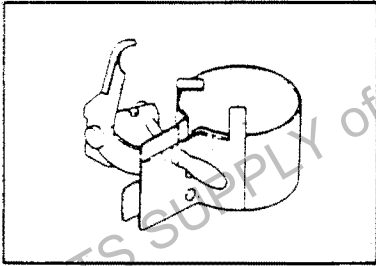

09441-1260

FLY WHEEL HOUSING OIL SEAL PRESS

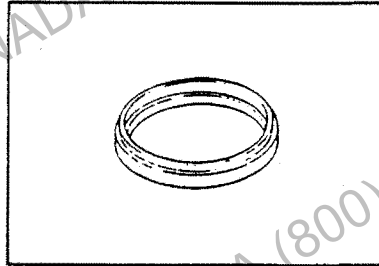

09482-1540

MARINE PARTS SUPPLY of CANADA (800)661-5353

CYLINDER HEAD

OVERHAUL

ME11-040-00X02 (1310)

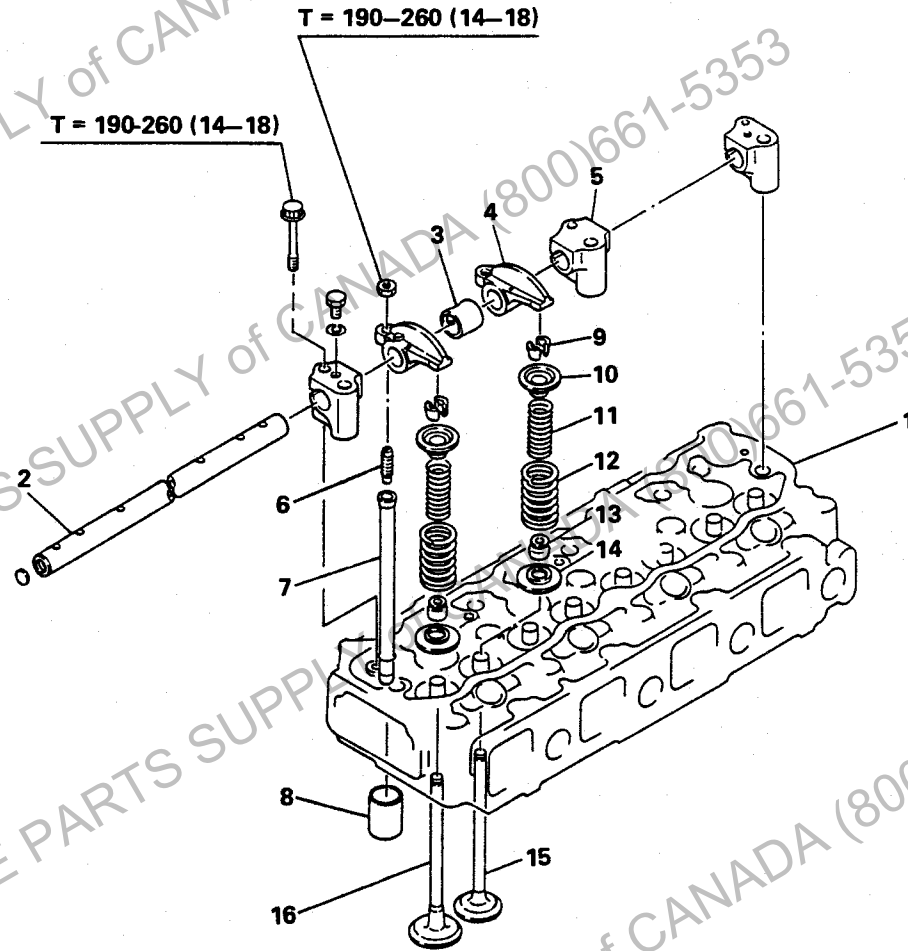

T = Tightening torque kg-cm (lb.ft)

- | | | |
|------------------------------------|-----------------------------------|-----------------------------|
| 1. Cylinder head | 7. Push rod | 13. Valve stem oil seal |
| 2. Rocker arm shaft | 8. Tappet | 14. Valve spring lower seat |
| 3. Bushing | 9. Cotter key | 15. Exhaust valve |
| 4. Rocker arm | 10. Valve spring upper seat | 16. Intake valve |
| 5. Rocker arm support | 11. Inner valve spring (For W04D) | |
| 6. Valve clearance adjusting screw | 12. Outer valve spring | |

OVERHAUL

T = 450-500 (33-36)

T = 130-190 (10-13)

T = 1,300-1,400 (94-101)

T = 130-190 (10-13)

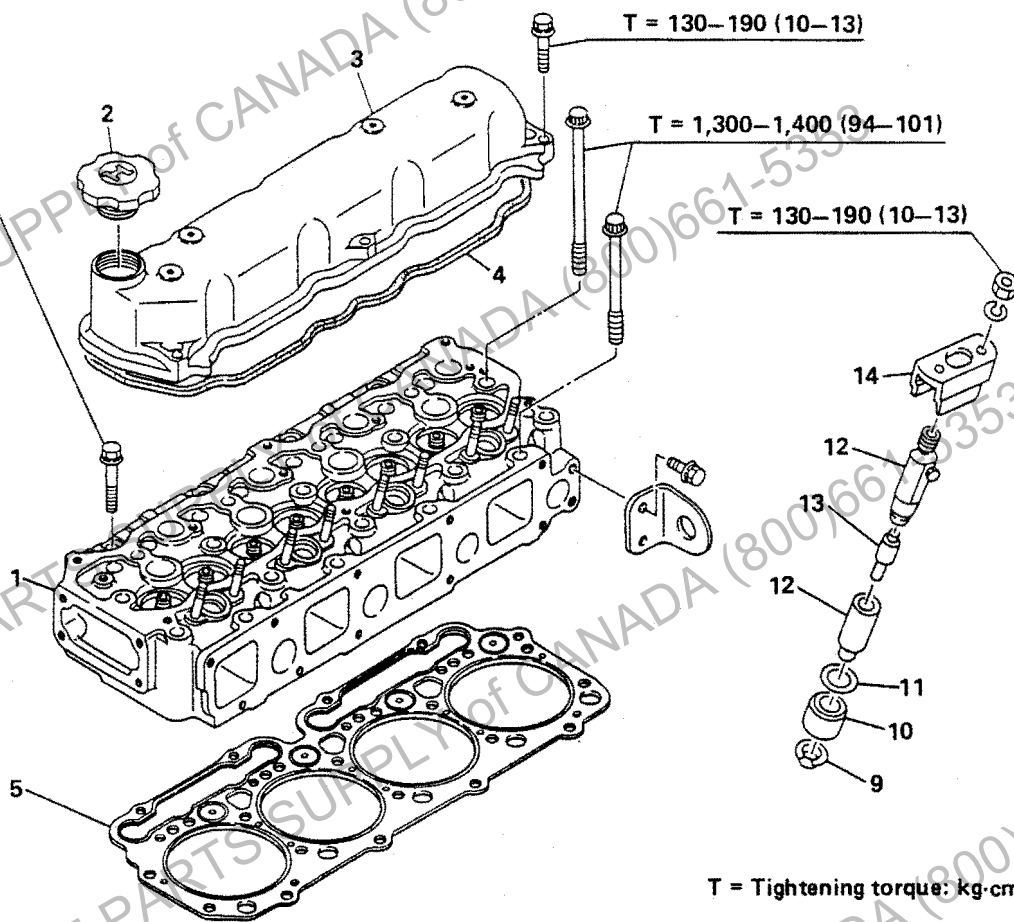

T = Tightening torque: kg-cm (lb.ft)

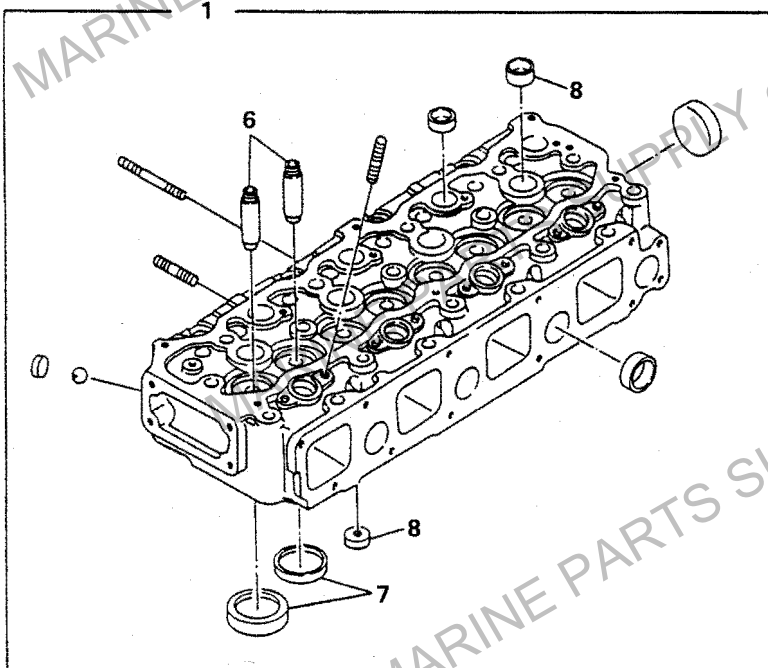

- 1. Cylinder head
- 2. Oil filler cap
- 3. Cylinder head cover
- 4. Cylinder head cover gasket
- 5. Cylinder head gasket
- 6. Valve guide
- 7. Valve seat
- 8. Expansion plug
- 9. Nozzle holder gasket
- 10. Packing ring
- 11. Shim
- 12. Nozzle holder
- 13. Nozzle
- 14. Nozzle holder adapter

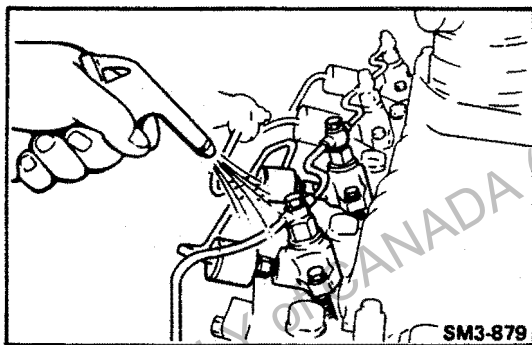
**IMPORTANT POINTS – DISASSEMBLY**

CLEAN OFF SURROUNDING AREA OF THE NOZZLES AND THE FUEL LINE CONNECTORS.

NOTE: If foreign matter is allowed to enter the combustion chamber, engine trouble may result.

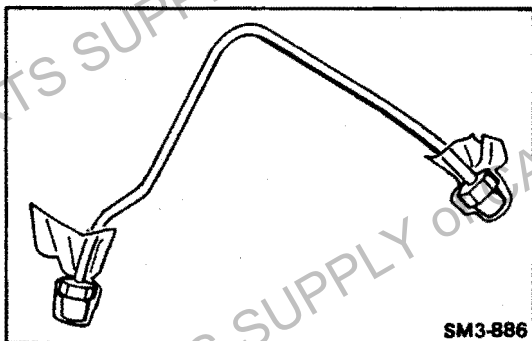
**REMOVE THE INJECTION PIPES.**

NOTE: Cover open ends of the pipes to prevent entry of dirt.

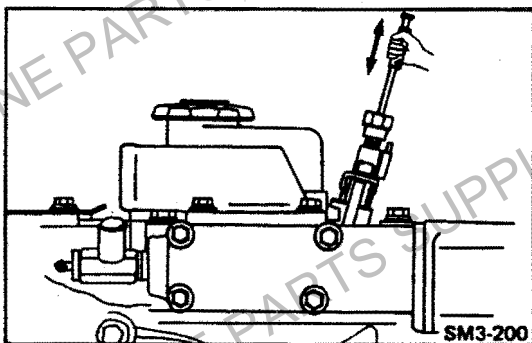
**REMOVE THE NOZZLE ASSEMBLY.**

Using a special tool, if the nozzle is difficult to remove by hand.

Special Tool: Sliding Hammer (09420-1442)
Adapter (09462-1370) for W04D
(09462-1130) for W04C-T, W04C-T1

NOTE: ○ After removal of the nozzle holder, cover the nozzle holder with cloth. Also cover the cylinder head with a cloth to prevent dust from getting in.

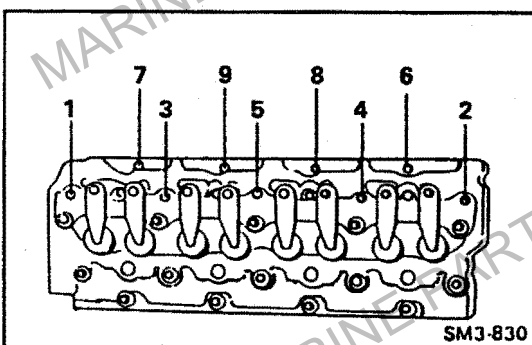
**REMOVE THE CYLINDER HEAD ADDITIONAL BOLTS AND ROCKER ARM SUPPORT BOLTS.**

Loosen the cylinder head additional bolts and rocker arm support bolts in the numerical order as shown.

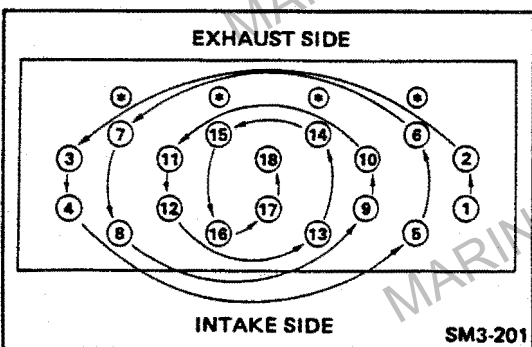
**LOOSEN THE CYLINDER HEAD BOLTS AND REMOVE THEM.**

Loosen the cylinder head bolts little by little in three stages and in the numerical order as shown.

Special Tool: Wrench (09411-1280)

* Mark position (Cylinder head additional bolts)

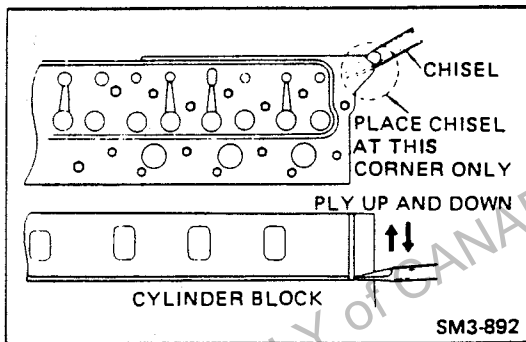

LIFT THE CYLINDER HEAD FROM THE DOWELS ON THE CYLINDER BLOCK AND PLACE IT ON WOODEN BLOCKS

1. If the cylinder head is difficult to lift off, pry with a chisel between the cylinder head and block.

NOTE: Do not damage the machined surface of the head or block when removing the cylinder head.

**Special Tool: Eye Bolt (09433-1070)
Wire (09491-1010)**

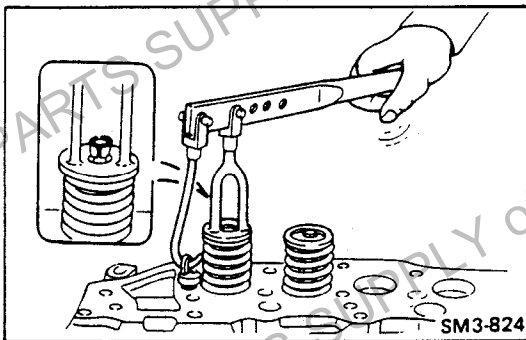

REMOVE THE VALVE SPRINGS.

1. Remove the valve stem cotters, upper valve seats, and inner (for W04D) and outer valve springs from cylinder head.

Special Tool: Valve Spring Press (09470-1022)

2. Remove the intake and exhaust valves.

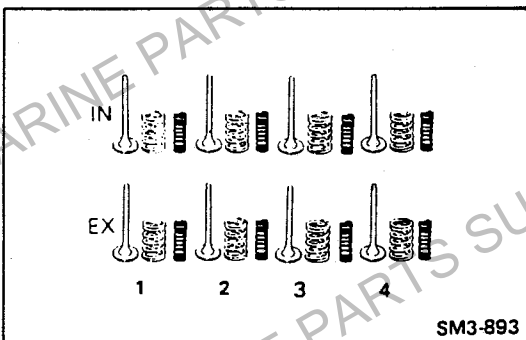

3. Tag valves to identify their cylinder numbers and to eliminate valve lapping.

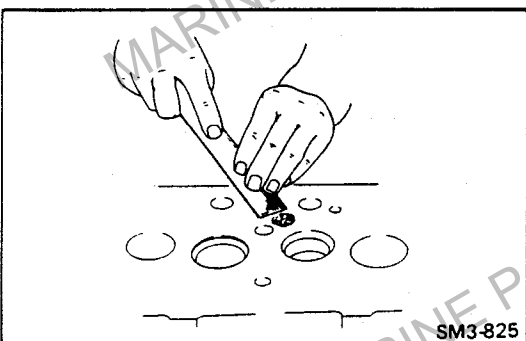

IMPORTANT POINTS – ASSEMBLY

CLEAN THE CYLINDER HEAD THOROUGHLY WITH A SUITABLE SOLVENT.

NOTE: Be careful not to damage the cylinder head surface.

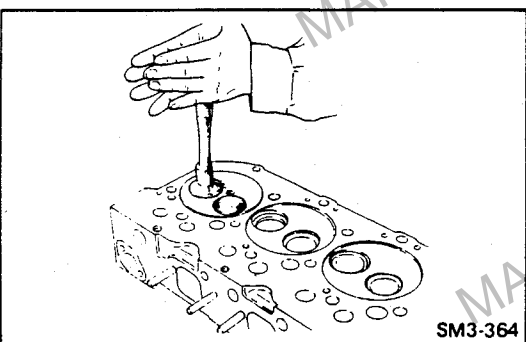

IF NECESSARY, HAND-LAP THE VALVE AND VALVE SEAT.

Lightly apply lapping compound to the valve face. Install the valve with a special tool, tap and rotate the valve against the seat.

Special Tool: Valve Lapping Tool (09431-1010)

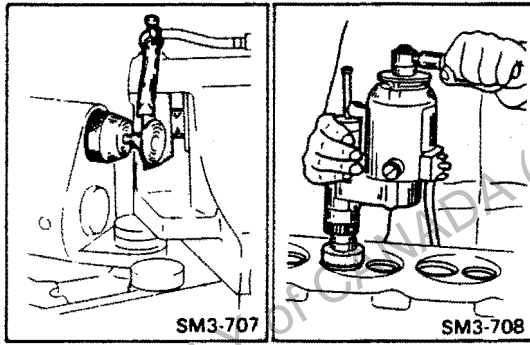

IF NECESSARY, GRIND THE VALVES AND VALVE SEATS.

- NOTE:
- Grinding of valves and valve seats should only be performed when hand-lapping does not result in proper seating.
 - After grinding, always recheck the valve sink.

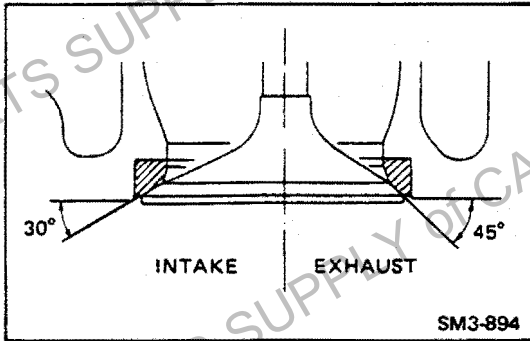

Standard:

- Valve Seat (Intake) : 30° - 30°30'
- Valve Face (Intake) : 29°45' - 30°15'
- Valve Seat (Exhaust) : 45° - 45°30'
- Valve Face (Exhaust) : 44°45' - 45°15'

IF NECESSARY, REPLACE THE VALVE SEAT.

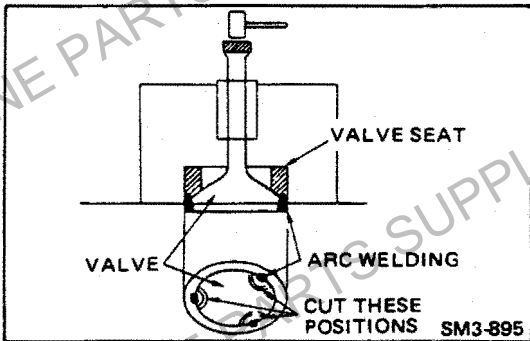

1. Cut the circumference of a valve head at three places with a grinder and install it into the seat as shown and weld the valve to the seat. Then drive the valve and the seat out with a hammer and a brass block.

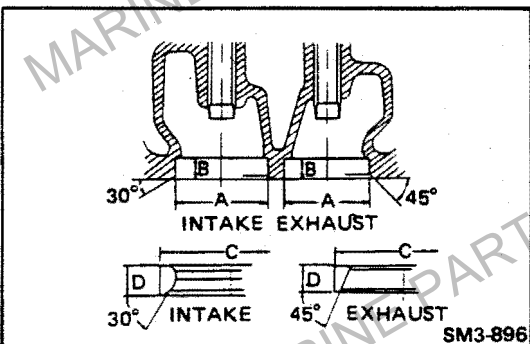

2. Valve seat section machining specifications. Unit: mm (in)

		Intake	Exhaust
Cylinder head dimension	A	46.500-46.516 (1.8308-1.8313)	41.000-41.016 (1.6142-1.6148)
	B	8.8-9.0 (0.3465-0.3543)	7.2-7.4 (0.2835-0.2913)
Valve seat dimension	C	46.585-46.600 (1.8341-1.8346)	41.130-41.145 (1.6193-1.6198)
	D	7.5-7.7 (0.2953-0.3031)	6.0-6.2 (0.2363-0.2440)

3. Valve seat installation

Heat the cylinder head to 80°-100°C (176-212°F) with hot water. On the other hand, cool the valve seat with dry ice or liquid freon for approx. 30 minutes. Hold the seat with pincers and place it into the heated cylinder head.

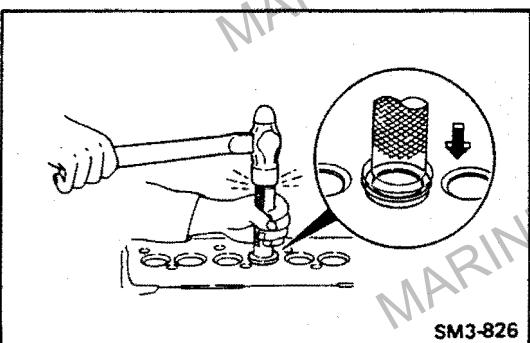

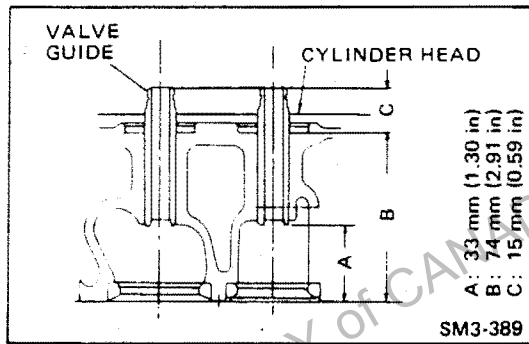
**IF NECESSARY, REPLACE THE VALVE GUIDE.**

1. Remove the valve stem seal.
2. Using a brass rod and hammer, drive out the valve guide.
3. Install the valve guide as shown.

NOTE: Apply engine oil lightly to the valve guide outer circumference before installing.

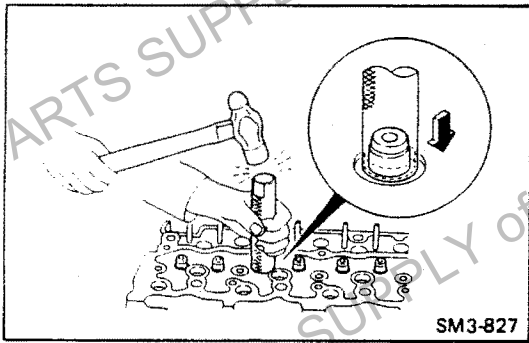
**IF NECESSARY, REPLACE THE VALVE STEM SEAL.**

1. Remove the valve stem seal.
2. Install the valve stem seal.

First, install the lower spring seat (for stopper of special tool) and valve. Then apply engine oil to the lip of the stem seal and drive the special tool until it hits the lower spring seat.

Special Tool: Valve Stem Seal Press (09472-1650)

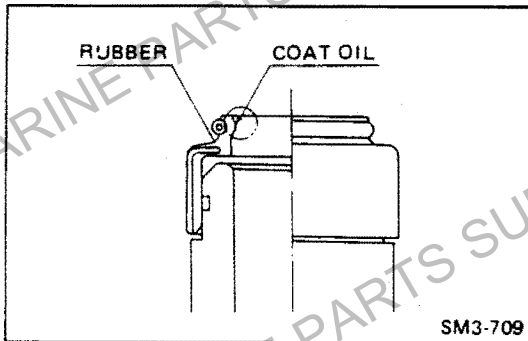

- NOTE:**
- After installing stem seal, make sure that check the rubber position for cracks or any other damage.
 - Do not use the special tool if its tip (surface contacting lower spring seat) is worn or deformed.

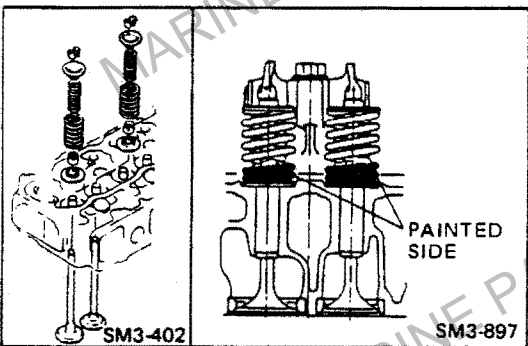
**ASSEMBLE THE CYLINDER HEAD.**

- NOTE:**
- Apply engine oil to contact surfaces of all parts.
 - Make sure that the valves are installed in the correct cylinders.
 - Install the valve springs with their painted side down, since they have variable pitches.

Press upper spring seats and install the valve stem keys securely in the upper spring seats.

Special Tool: Valve Spring Press (09470-1022)

- NOTE:**
- When pressing with the valve spring press, be careful not to damage the stem seals by contacting the upper seats.
 - Drive the valve stem lightly with a hammer to assure proper fit the valve stem key.

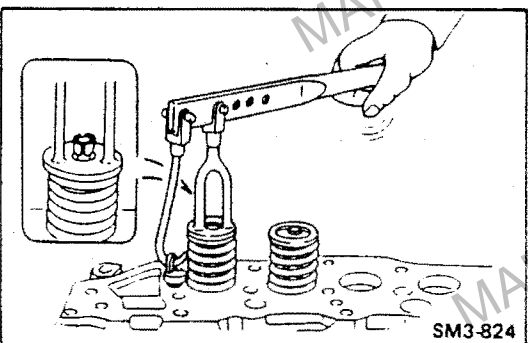

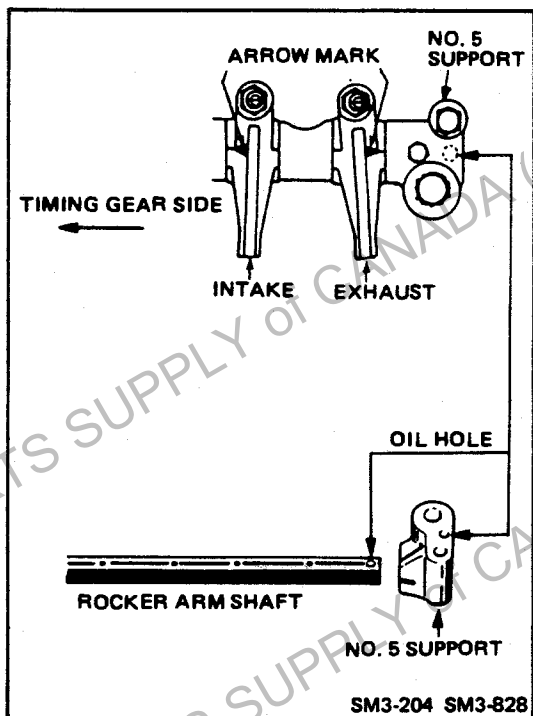

ASSEMBLE THE ROCKER ARM.

Lubricate the rocker arm shaft and bushing.

NOTE: Confirm that oil hole of rocker arm assembly No. 5 support aligns with shaft oil hole. Improper installation will result in burning of the entire valve assembly.

INSTALL THE TAPPETS IN THE CYLINDER BLOCK IN CORRECT ORDER.

NOTE: Apply engine oil to the tappet faces and tappet guide when installing them in the cylinder block.

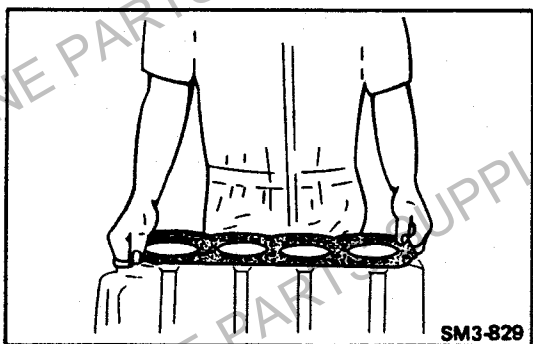

INSTALL THE CYLINDER HEAD AND ROCKER ARM ASSEMBLY.

1. Install the cylinder head gasket.

NOTE: Always use new cylinder head gasket after cleaning the surfaces of the cylinder head, cylinder block and head gasket free of all dirt, water and grease.

2. Install the cylinder head over the dowels on the cylinder block.

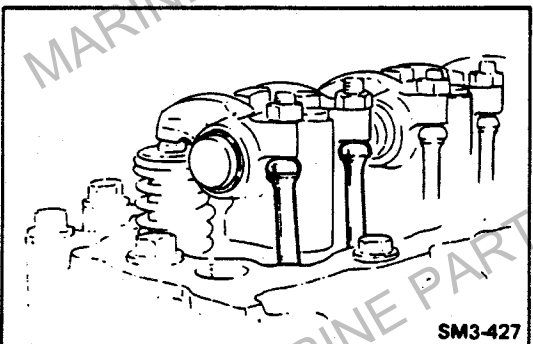

3. Insert the push rods in correct order, after applying engine oil to both ends.

4. Mount the rocker arm assembly on the cylinder head, make sure that the push rods interlock with the adjusting screws.

NOTE: Always loosen the lock nut and raise the adjusting screws fully to the top.

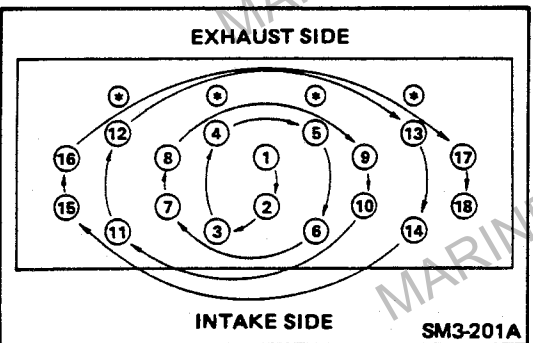

5. Tighten the cylinder head bolts little by little in three stages and in the numerical order as shown.

NOTE: Apply engine oil to the bolt threads and under the bolt head.

- Mark bolts (cylinder head additional bolt): ϕ 10 mm (0.39 in)
- No. 1 – No. 18 Bolts (Cylinder head bolt): ϕ 12 mm (0.47 in)

Special Tool: Wrench (09411-1260)

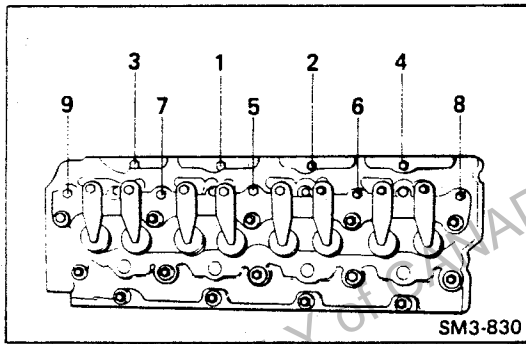

6. Tighten the cylinder head additional bolts and rocker arm support bolts little by little in three stages and in the numerical order as shown. Tighten the bolts to the specified torque.

7. Retighten the cylinder head bolts.



NOTE: Refer to SECTION ENGINE TUNE-UP.

INSPECTION AND REPAIR

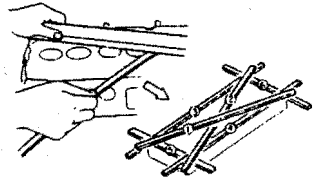
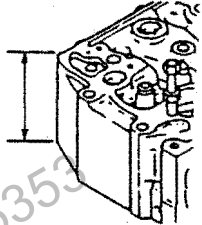
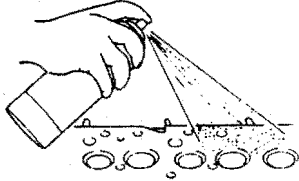
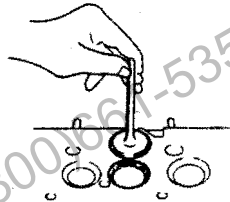
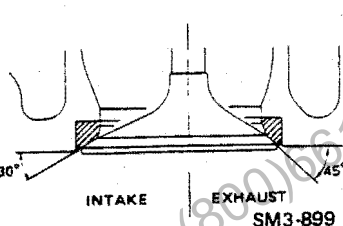
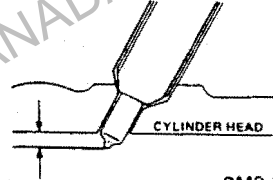
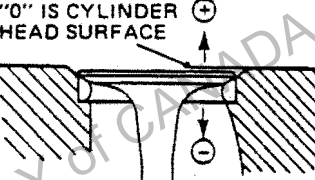
Unit: mm (in)

Inspection Item		Standard	Limit	Remedy	Inspection Procedure
Cylinder Head Flatness		0.05 (0.0019)	0.1 (0.0039)	Regrind or replace	 SM3-831
Cylinder Head Height		87.0 (3.425)	86.8 (3.417)	Replace	 SM3-887
Cylinder Head Cracks and Damage * Using a Dye Penetrant		-	-	Replace, if necessary	 SM3-832
Valve Seating Condition * Using Red Lead Marking Compound		There should be good contact around entire circumference of valve head.	-	Hand-lap with lapping compound	 SM3-833
Valve Seat Angle	Intake	30°-30°30'	-	Regrind or replace valve and/or valve seat	
	Exhaust	45°-45°30'			
Valve Angle	Intake	29°45'-30°15'	-		30° INTAKE 45° EXHAUST SM3-899
	Exhaust	44°45'-45°15'			
Nozzle Protrusion from Cylinder Head Surface		2.75-3.25 (0.1083-0.1279)	-	Replace nozzle gasket	 SM3-391
Intake Valve Sink	W04D	-0.15 - -0.45 (-0.0059 - -0.0177)	-0.55 (-0.0216)	Replace valve and/or valve seat	"0" IS CYLINDER HEAD SURFACE 
	W04C-T W04C-TI	0.05 - 0.35 (0.0019-0.0137)	-0.05 (-0.0019)		
Exhaust Valve Sink		-0.47 - -0.77 (-0.0185 - -0.0303)	-0.87 (-0.0342)		SM3-236

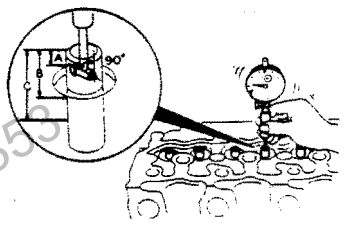
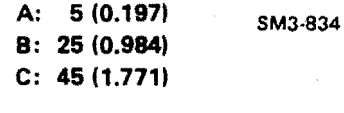
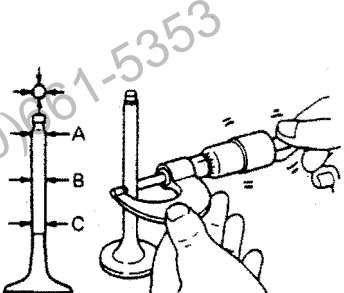
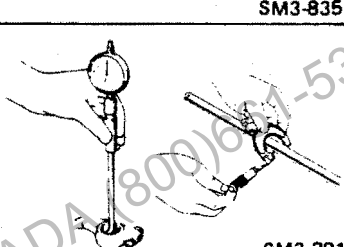
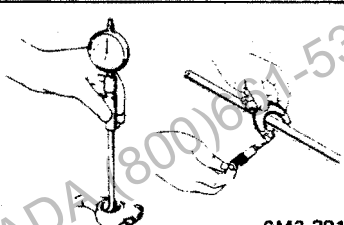
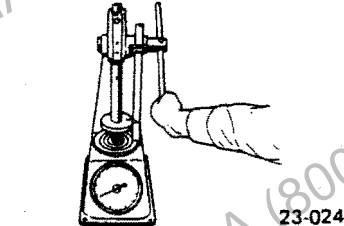
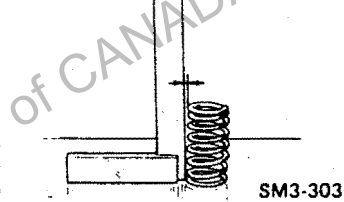
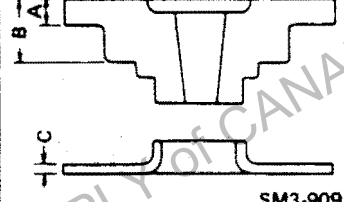
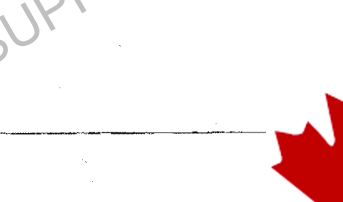
Unit: mm (in)

Inspection Item	Standard	Limit	Remedy	Inspection Procedure
Intake Valve Stem Diameter	8.95—8.97 (0.3524—0.3531)	8.90 (0.3903)	Replace valve guide and/or valve	
Exhaust Valve Stem Diameter	8.93—8.95 (0.3516—0.3524)	8.80 (0.3464)		
Intake and Exhaust Valve Guide Diameter	9.000—9.015 (0.3544—0.3549)	A & B: 9.05 (0.3562) C: 9.10 (0.3582)		 <p>A: 5 (0.197) B: 25 (0.984) C: 45 (1.771)</p> <p>SM3-834</p>
Clearance between Valve Stem and Valve Guide (Intake)	0.035—0.068 (0.0004—0.0026)	A & B: 0.10 (0.0040) C: 0.18 (0.0071)		 <p>SM3-835</p>
Clearance between Valve Stem and Valve Guide (Exhaust)	0.050—0.083 (0.0020—0.0032)	A & B: 0.12 (0.0047) C: 0.2 (0.0078)		 <p>SM3-835</p>
Rocker Arm Shaft Diameter	18.97—18.98 (0.7469—0.7472)	18.95 (0.7461)	Replace rocker arm bush and/or shaft	 <p>SM3-291</p>
Clearance between Rocker Arm Shaft and Rocker Arm Bush	0.036—0.079 (0.0015—0.0031)	0.1 (0.0039)		 <p>SM3-291</p>
Inner Valve Spring Setting Load (For W04D only)	8.8 kg (19.4 lb) at 43.0 mm (1.69 in)	8.0 kg (17.6 lb)	Replace	 <p>23-024</p>
Outer Valve Spring Setting Load	27.4 kg (54.5 lb) at 45.5 mm (1.79 in)	25.5 kg (56.2 lb)		 <p>SM3-303</p>
Valve Spring Straightness (Inner and Outer)	-	2.0 (0.0787)	Replace	 <p>SM3-909</p>
Valve Spring Seat for Wear	A: 2.5 (0.0984) B: 5.0 (0.1969) C: 1.0 (0.0394)	-	Replace	 <p>SM3-909</p>

Unit: mm (in)

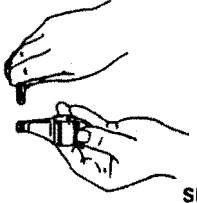
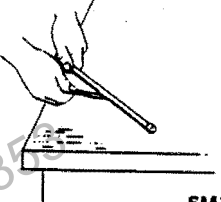
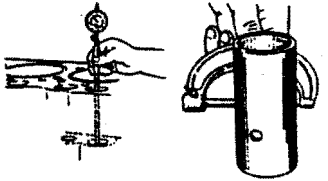
Inspection Item	Standard	Limit	Remedy	Inspection Procedure
Valve Stem Tip Surface for Wear	-	-	Resurface or replace	Visual Check 
Valve Stem Contact Surface of Rocker Arm for Wear				
Push Rod Bend	-	0.3 (0.0118)	Replace	 SM3-292
Tappet Diameter	26.95–26.97 (1.0611–1.0618)	-	Replace tappet	 SM3-420 SM3-293
Tappet Guide Inside Diameter	27.00–27.02 (1.0630–1.0637)			
Clearance between Tappet and Tappet Guide	0.025–0.071 (0.0010–0.0029)			
Tappet for Wear	Should not be worn unevenly.	-	Replace, if necessary	Visual Check

TIMING GEAR, CAMSHAFT AND OIL PAN

OVERHAUL

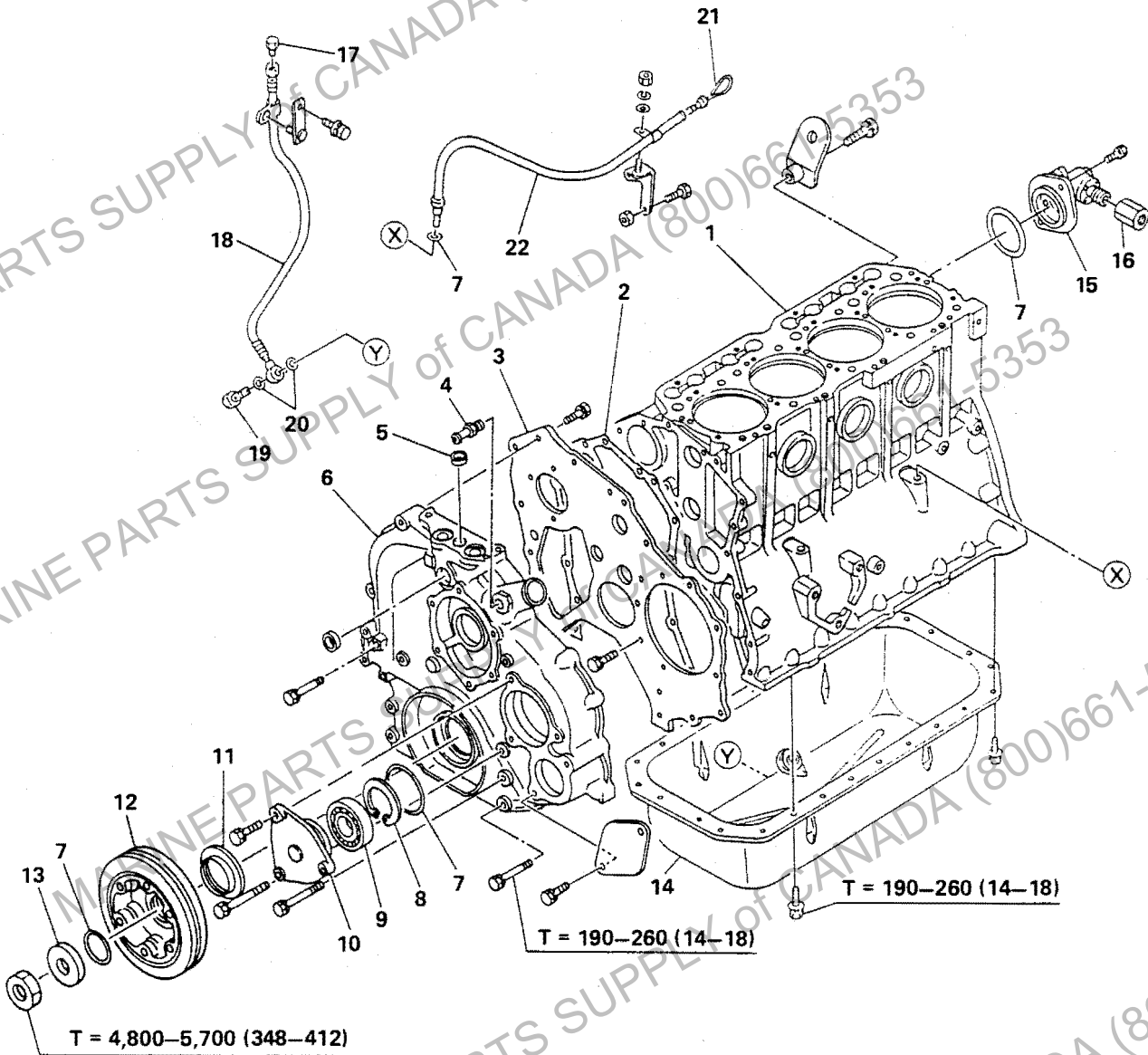

T = Tightening torque: kg-cm (lb.ft)

- | | | |
|----------------------|-------------------------------|---------------------------|
| 1. Cylinder block | 9. Ball bearing | 17. Oil drain plug |
| 2. Gasket | 10. Bearing holder case | 18. Oil drain hose |
| 3. Timing gear plate | 11. Oil seal | 19. Connector bolt |
| 4. Connector | 12. Crankshaft pulley | 20. Soft washer |
| 5. Expansion plug | 13. Plain washer | 21. Oil level gauge |
| 6. Timing gear cover | 14. Oil pan | 22. Oil level gauge guide |
| 7. O-ring | 15. Tachometer drive assembly | |
| 8. Retainer ring | 16. Connector | |

OVERHAUL

T = 1,100-1,300 (80-94)

T = 190-260 (14-18)

T = 190-260 (14-18)

T = 1,100-1,300 (80-94)

T = 300-350 (22-25)

- | | | |
|------------------------|----------------------------|-------------------------------|
| 1. Camshaft | 7. Idler gear thrust plate | 13. Injection pump drive gear |
| 2. Key | 8. Straight pin | 14. Coupling flange |
| 3. Thrust bearing | 9. Idler gear shaft | 15. O-ring |
| 4. Camshaft gear | 10. Bearing | 16. Timer cover |
| 5. Thrust washer | 11. Idler gear | 17. Soft washer |
| 6. Oil pump drive gear | 12. Crankshaft gear | 18. Plug |

T = Tightening torque: kg-cm (lb.ft)

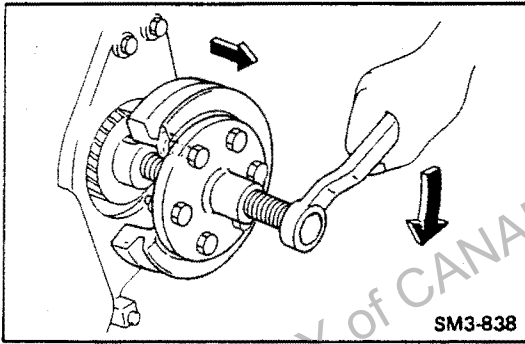
**IMPORTANT POINTS – DISASSEMBLY****REMOVE THE CRANKSHAFT PULLY.**

1. Remove the nut and spacer.
2. Using a special tool, remove the pulley.

Special Tool: Crankshaft pulley Puller (09420-1500)

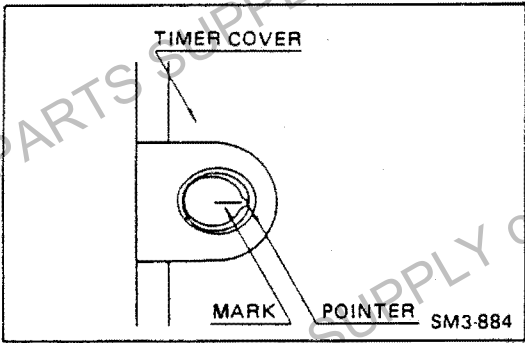
**DISMOUNT THE FUEL INJECTION PUMP.**

1. Remove the plug from the port on the timer cover.
2. Turn the crankshaft counter-clockwise viewed from flywheel side to align the injection timing mark.

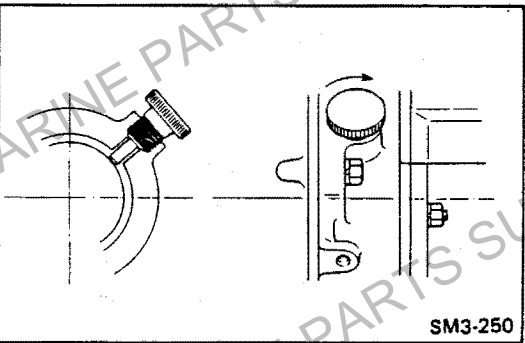

3. Lock the coupling flange with a special tool.

Special Tool: Timer Setting Tool

(09512-2090) for W04D

(09512-2100) for W04C-T, W04C-T1

NOTE: Do not loosen the injection pump drive gear fitting bolts.

4. Loosen the timer cover fitting bolts and then remove the injection pump with timer cover.

NOTE: Do not loosen the injection pump body fitting nuts.

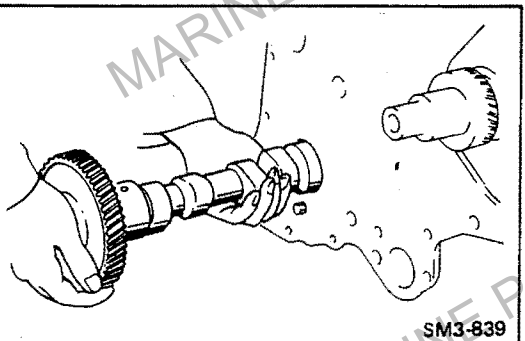
**REMOVE THE CAMSHAFT WITH GEAR.**

NOTE: Pull out the camshaft, slowly turning it so as not damage the bearings.

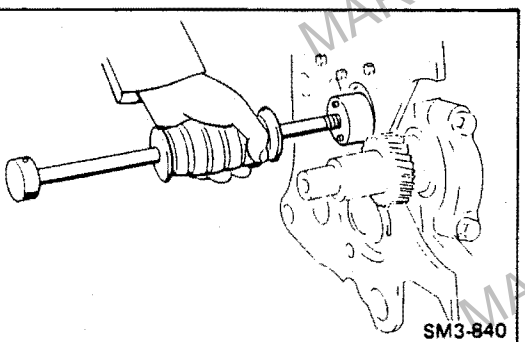
**REMOVE THE IDLER GEAR SHAFT.**

Using a special tool, remove the idler gear shaft.

Special Tool: Sliding Hammer (09420-1100)

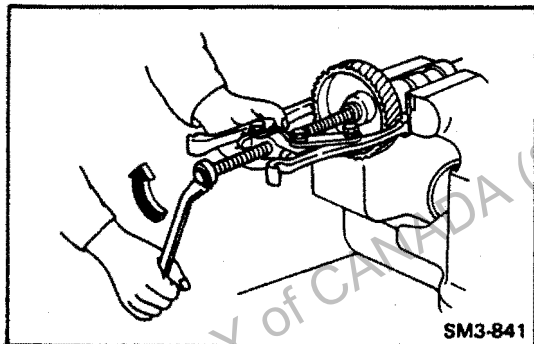

SM3-841

IF NECESSARY, REMOVE THE CAMSHAFT GEAR.

1. Hold the camshaft with a vice through wooden plates.
2. Remove the bolt and plain washer, then using a gear puller, remove the gear.

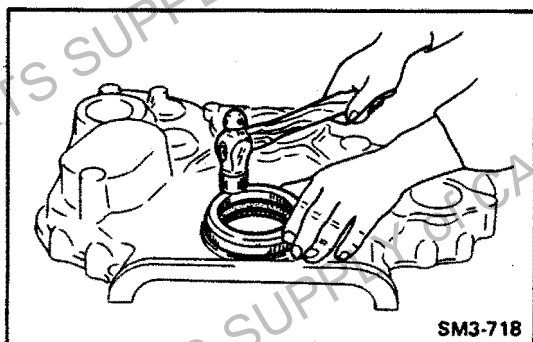

SM3-718

IMPORTANT POINTS – ASSEMBLY**IF NECESSARY, REPLACE THE TIMING GEAR CASE COVER OIL SEAL.**

1. Using a screwdriver, remove the oil seal.
2. Using a special tool, install the new oil seal.

Special Tool: Press (09482-1530)

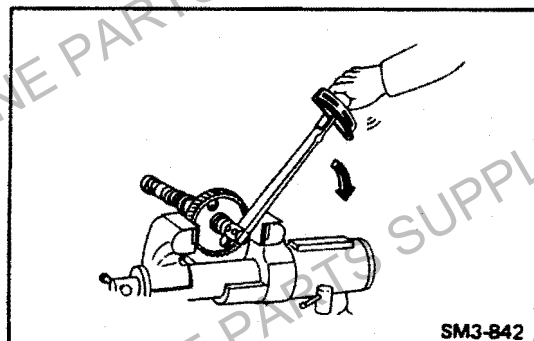

SM3-842

ASSEMBLE THE CAMSHAFT GEAR AND SHAFT.

Install the camshaft gear with thrust bearing.

NOTE: When installing the gear to the camshaft:

- Heat the gear in hot water [Approx. 100°C (212°F)], then install the gear to the camshaft by using a press.
- When tightening the bolt, apply engine oil to the threads and plate surface of the bolt.

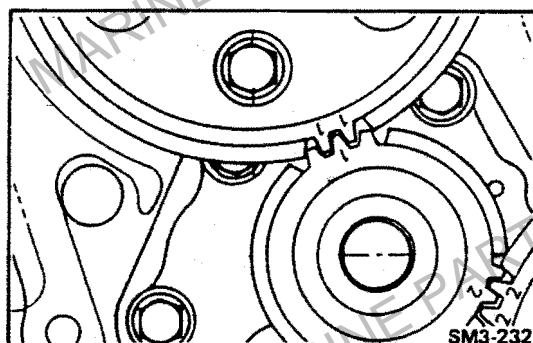

SM3-232

INSTALL THE CAMSHAFT.

Lubricate all journals of the camshaft and insert the camshaft assembly into the cylinder block.

- NOTE:**
- Insert the camshaft, slowly turning while inserting so that the bearing will not be damaged.
 - When installing the camshaft, be sure that the match marks of the oil pump drive gear and camshaft gear are aligned correctly.

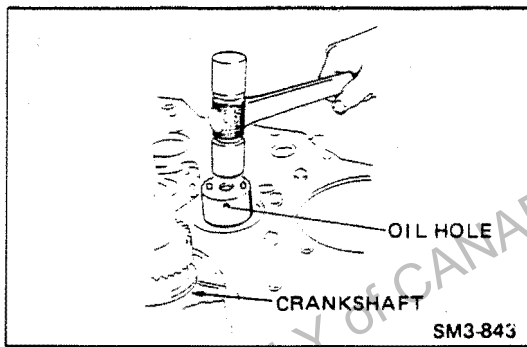
**INSTALL THE IDLER GEAR SHAFT.**

Install the idler gear shaft with thrust plate using a plastic hammer.

NOTE: Be sure that the oil hole is downward, if installed the wrong way, damage to the idler gear shaft and bearing can result.

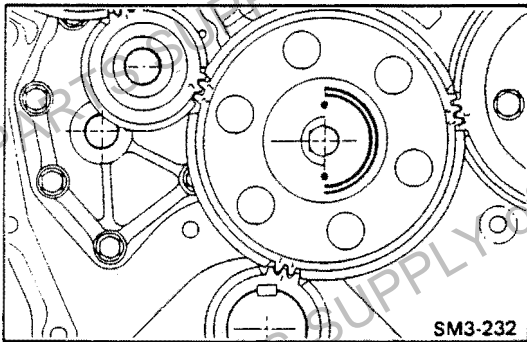
**INSTALL THE IDLER GEAR.**

NOTE: When installing the idler gear, be sure that the matching marks of the crankshaft gear, oil pump drive gear and idler gear are aligned correctly.

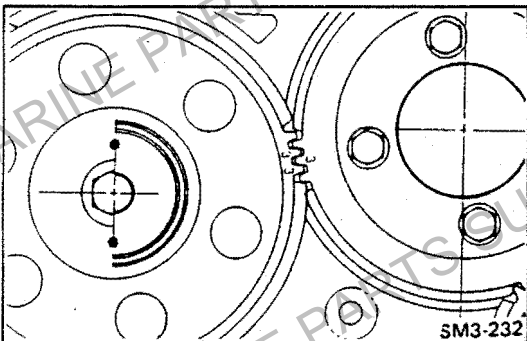
**INSTALL THE INJECTION PUMP TEMPORARILY.**

NOTE: When installing the injection pump, be sure that the match marks of the idler gear and injection pump drive gear are aligned correctly.

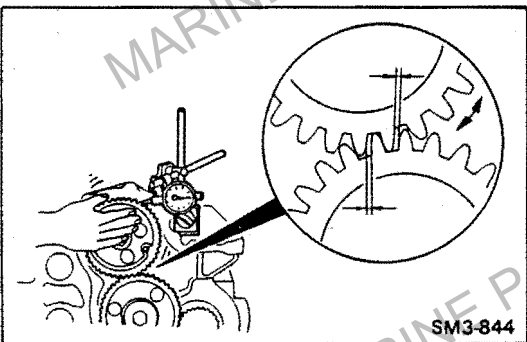
**MEASURE THE GEAR BACKLASH.**

Measure the backlash of each gear using a dial indicator.
Replace the gear if necessary.
Refer to **INSPECTION AND REPAIR**.

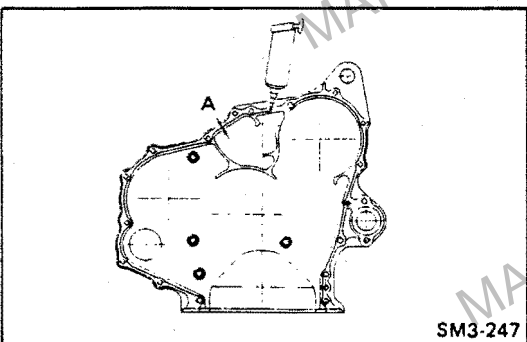
**INSTALL THE TIMING GEAR CASE.**

1. Clean the faces.
2. Apply the liquid gasket as shown and install the timing gear cover within 20 minutes.

NOTE: If leaving it more than 20 minutes, clean the liquid gasket completely and reapply the liquid gasket.

Coating Width (A): 1.5 – 2.5 mm (0.06 – 0.10 in)

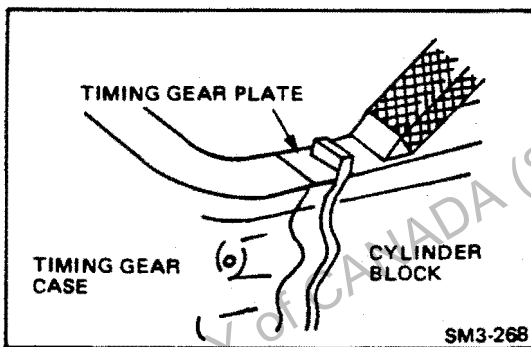

INSTALL THE OIL STRAINER.

Refer to "OIL PUMP AND OIL STRAINER" in SECTION LUBRICATING SYSTEM.

INSTALL THE OIL PAN.

1. Cut the protrusion of the timing gear plate gasket from the oil pan mounting surface.
2. Clean the faces.
3. Apply the liquid gasket as shown and install the oil pan within 20 minutes.

NOTE: If leaving it more than 20 minutes, clean the liquid gasket completely and reapply the liquid gasket.

Coating Width (A): 3 – 4 mm (0.12 – 0.15 in)

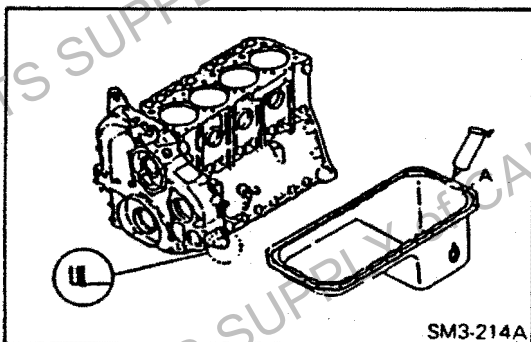

INSTALL THE CRANKSHAFT PULLEY.

NOTE: Apply engine oil to the nut threads.

INSPECTION AND REPAIR

Unit: mm (in)

Inspection Item	Standard	Limit	Remedy	Inspection Procedure
Gear Teeth for Pitting or Wear	-	-	Replace, if necessary	Visual check SM3-845
Idler Gear Shaft Diameter	49.95–49.97 (0.9311–1.9318)	49.94 (1.9307)	Replace bushing and/or shaft	 SM3-846
Idler Gear Bushing Inside Diameter	50.00–50.03 (1.9685–1.9696)	50.05 (1.9705)		
Clearance between Idler Gear Shaft and Bushing	0.03–0.08 (0.0012–0.0031)	0.1 (0.0039)		
Idler Gear End Play	0.04–0.10 (0.0016–0.0039)	0.15 (0.0059)	Replace thrust plate	 SM3-421

Unit: mm (in)

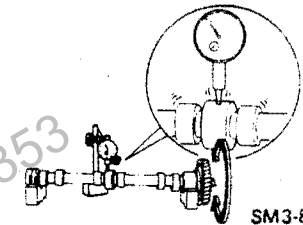
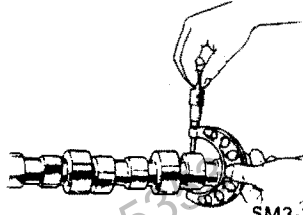
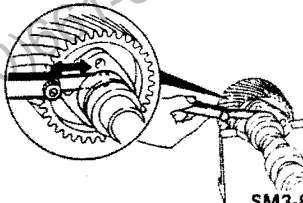
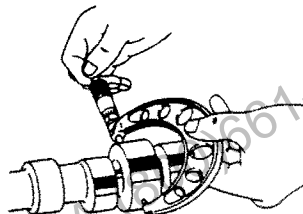
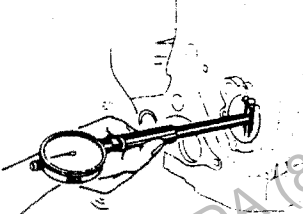
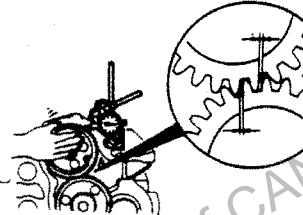
Inspection Item	Standard	Limit	Remedy	Inspection Procedure
Camshaft Bend	-	0.05 (0.0020)	Replace	 SM3-858
Camshaft Cam Height (Intake)	49.44 (1.9465)	48.44 (1.9071)	Replace	 SM3-374
Camshaft Cam Height (Exhaust)	49.50 (1.9488)	48.50 (1.9095)		
Camshaft end Play	0.10-0.18 (0.0040-0.0070)	0.3 (0.0118)	Replace thrust plate	 SM3-848
Camshaft Journal Diameter Journal No. :	No. 1: 57.0 (2.2441)	56.85 (2.2382)	Replace shaft and/or bushing	 SM3-849
	No. 2: 56.8 (2.2362)	56.85 (2.2303)		
	No. 3: 56.6 (2.2283)	56.45 (2.2224)		
Camshaft Journal Bearing Inside Diameter Journal No. :	No. 1: 57.0 (2.2441)	57.15 (2.2500)		 SM3-850
	No. 2: 56.8 (2.2362)	56.95 (2.2421)		
	No. 3: 56.6 (2.2283)	56.75 (2.2342)		
Clearnace between Camshaft Journal and Bearing	0.03-0.12 (0.0012-0.0047)	0.15 (0.0059)		
Timing Gear Backlash	Crankshaft Gear - Idler Gear	0.068-0.194 (0.0027-0.0076)	Replace gear, if necessary	 SM3-844
	Idler Gear - Oil Pump Gear	0.065-0.182 (0.0026-0.0071)		
	Oil Pump Gear - Camshaft Gear			
	Idler Gear - Injection Pump Gear			

PISTON, CRANKSHAFT, CYLINDER BLOCK AND FLYWHEEL HOUSING

OVERHAUL

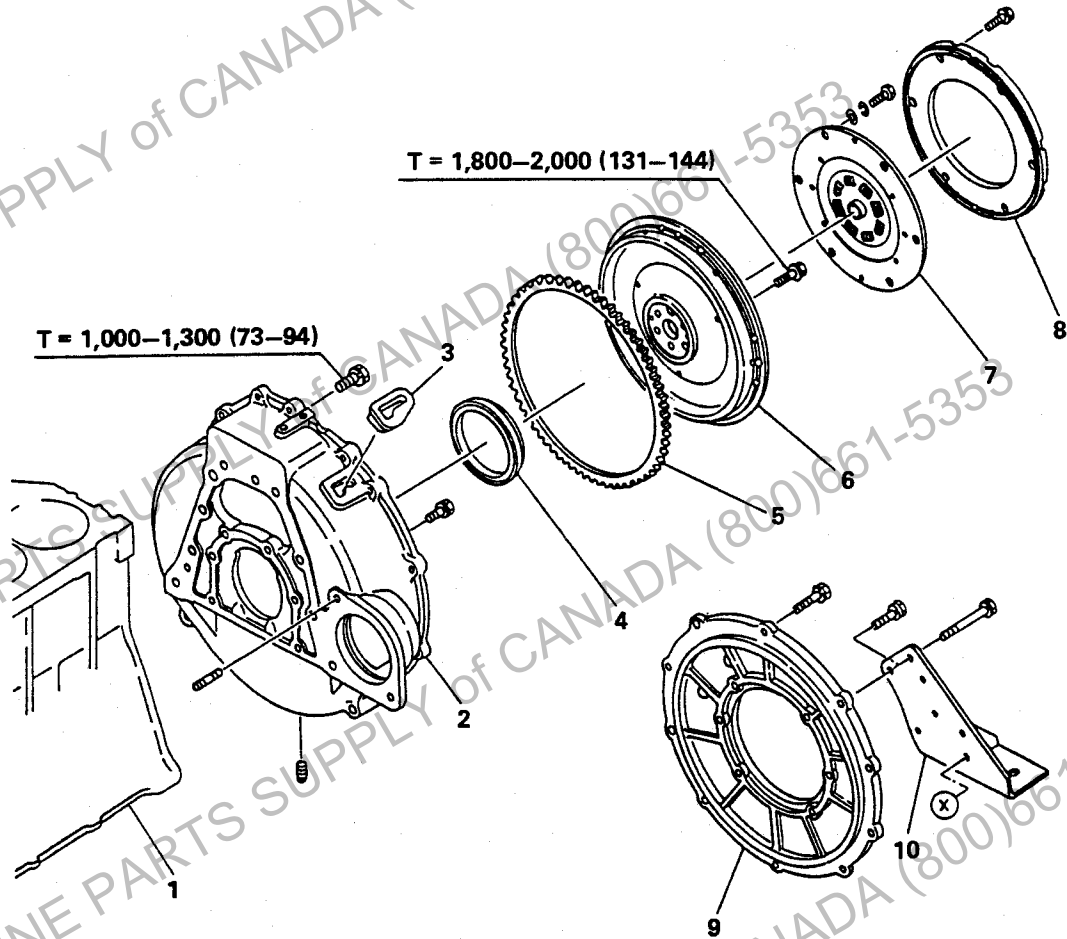

- 1. Cylinder block
- 2. Flywheel housing
- 3. Timing port cover
- 4. Oil seal

- 5. Ring gear
- 6. Flywheel
- 7. Torsion-elastic coupling
- 8. Spacer

T = Tightening torque: kg-cm (lb.ft)

- 9. Intermediate flange
- 10. Bracket

OVERHAUL

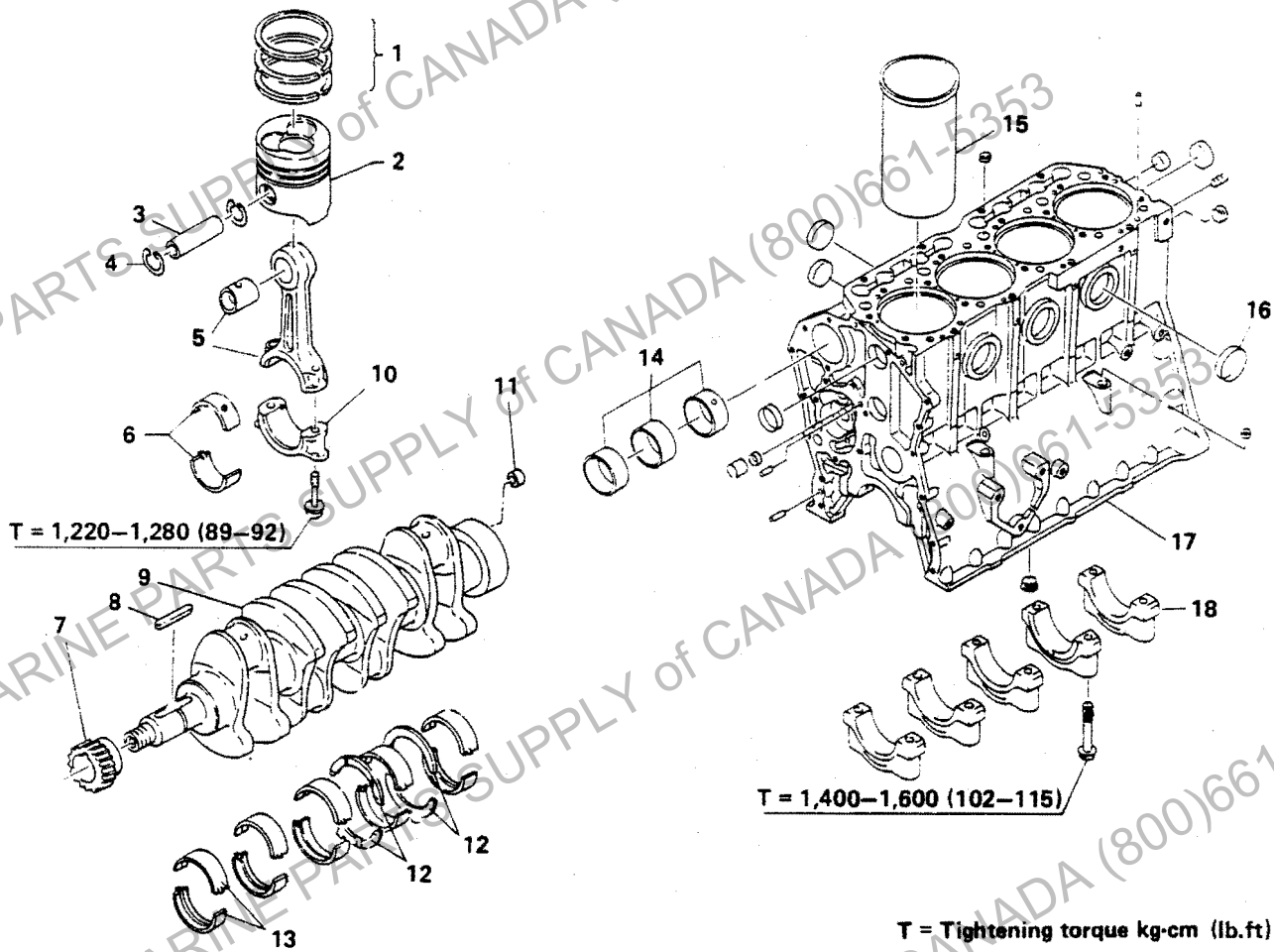

T = Tightening torque kg-cm (lb.ft)

SM3-1284

- | | | |
|---------------------------|------------------------------|------------------------|
| 1. Piston ring | 7. Crankshaft gear | 13. Crankshaft bearing |
| 2. Piston | 8. Key | 14. Camshaft bearing |
| 3. Piston pin | 9. Crankshaft | 15. Cylinder liner |
| 4. Retainer ring | 10. Connecting rod cap | 16. Expansion plug |
| 5. Connecting rod | 11. Collar | 17. Cylinder block |
| 6. Connecting rod bearing | 12. Crankshaft thrust washer | 18. Bearing cap |

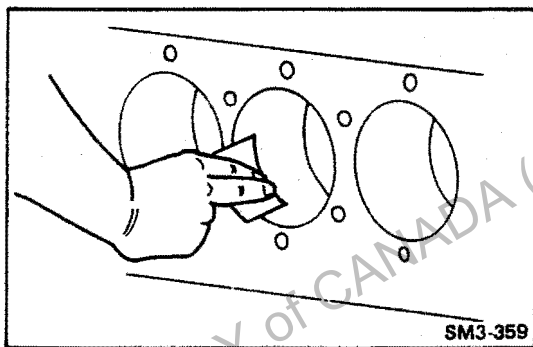

SM3-359

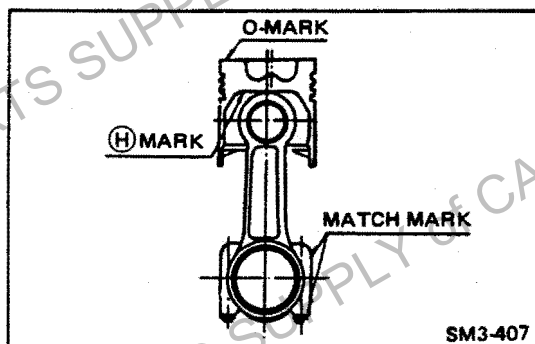

SM3-407

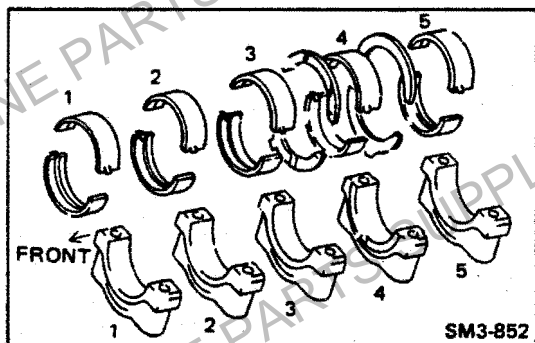

SM3-852

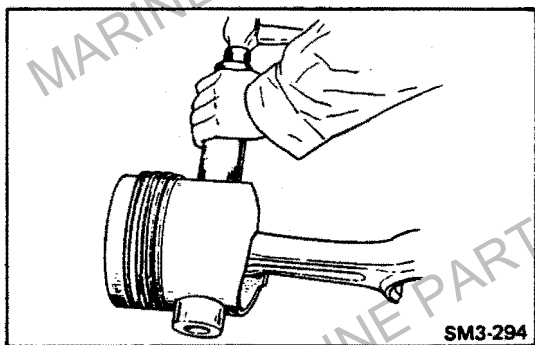

SM3-294

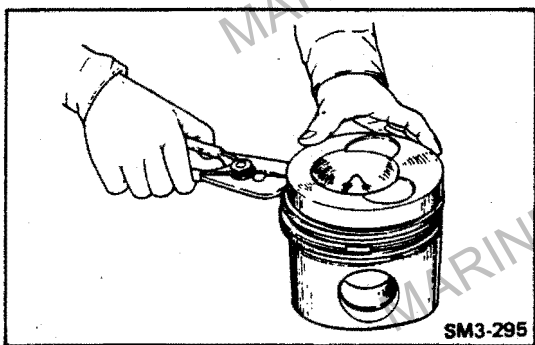

SM3-295

IMPORTANT POINTS – DISASSEMBLY

REMOVE THE PISTONS WITH CONNECTING RODS.

1. Remove the carbon from the upper end of the cylinder liner with a scraper or emery paper (recommended: No. 150) in a circular direction.

2. Extract the piston and connecting rod assembly out through the top of the cylinder.

NOTE: ○ Arrange the piston and connecting rod caps in order.

REMOVE THE CRANKSHAFT.

NOTE: Arrange the caps, bearings and thrust washers in order.

REMOVE THE CONNECTING ROD.

1. Remove the retainer ring installed on both ends of the piston pin, by means of retainer ring pliers.
2. Apply a metal pad to the pin and strike out the pin with a hammer.

NOTE: Warm up the piston first in hot water 80–90°C (176–194°F) for approx. 5 minutes before removing the pin.

REMOVE THE PISTON RINGS

Special Tool: Piston Ring Expander (09442-1180)

- NOTE:** ○ Handle the piston rings carefully because they are made of a special casting which is easily broken.
- Keep the rings for each cylinder separate.

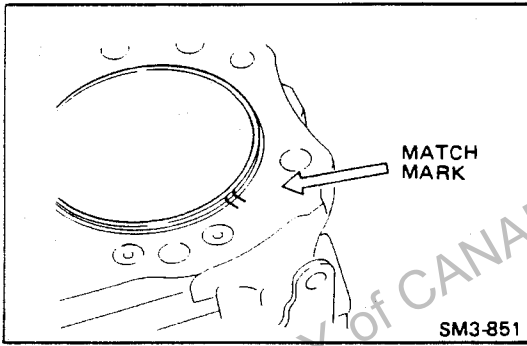

REMOVE THE CYLINDER LINER.

1. Place the match marks with a pen on the cylinder block and liner flange, before removing the cylinder liners.

NOTE: Do not put the match marks with a punch.

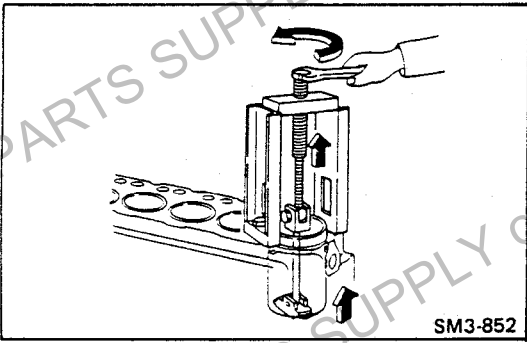

2. Using a special tool, remove the cylinder liners.

Special Tool: Cylinder Liner Puller (09420-1460)

NOTE: After removing the cylinder liners, put numbers on their periphery or arrange them in sequence.

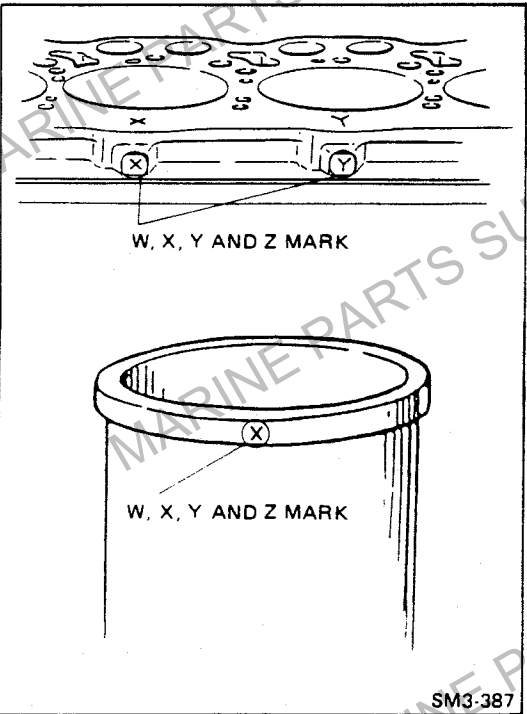

IMPORTANT POINTS – ASSEMBLY

INSERT THE CYLINDER LINER INTO THE CYLINDER BLOCK.

1. When a new cylinder liner is used, make sure that the liner has the same mark as the mark on the cylinder block.

NOTE: ○ There are 4 different liner and cylinder block matches. The flange section of each liner has a marking any, W, X, Y, Z, or indicating the size of the outer diameter of the liner on which it is stamped. The markings W, X, Y and Z, indicating the inner diameter of the cylinder bore supporting the liner on the sides and top of the cylinder block (the boss section for attaching the coolant gallery cover), are inscribed on each cylinder.

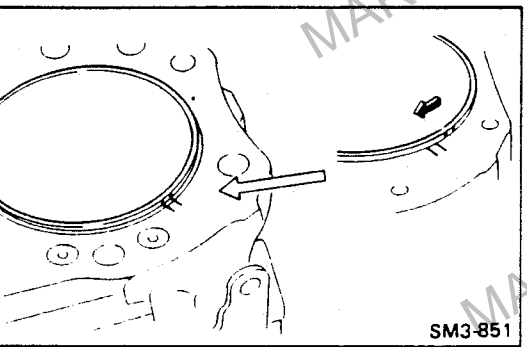

2. When reusing a liner, insert the liner its original position aligning the marking marked before disassembly.

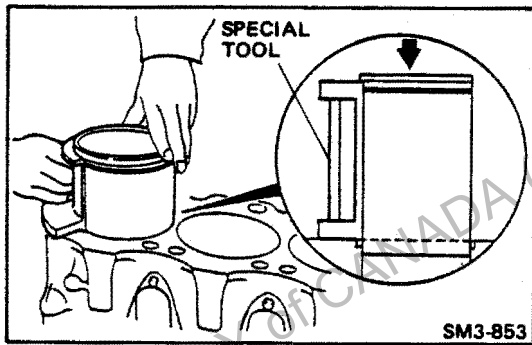

SM3-853

Apply a small amount of fresh engine oil on the outer periphery of the liner, and apply pressure on the entire flange section of the liner. If insertion by hand is difficult, use a cylinder guide, and the cylinder liner will easily be pushed in.

Special Tool: Cylinder Liner Guide (09480-1120)

- NOTE:**
- Do not use a liner that has been dropped.
 - Take extra care when handling the liner since the liner is easily deformed.

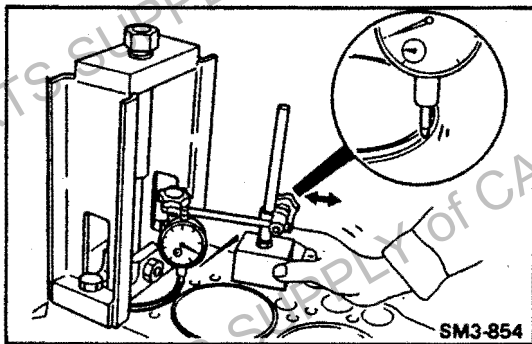

SM3-854

MEASURE THE PROJECTION OF THE CYLINDER LINER.

Tighten a special tool with a tightening torque of 100 kg-cm (7.23 lb-ft) and measure the amount of projection of the top end of the liner from the cylinder block with a dial gauge or straight edge and a thickness gauge.

Special Tool: Cylinder Liner Puller (09420-1460)

Tightening Torque: 100 kg-cm (7.23 lb.ft)

Assembly Standard: 0.01–0.08 mm (0.0004–0.0031 in)

Unit: mm (in)

Under size	Outside diameter	
	Crankpin	Journal
0.25	61.69–61.71 (2.4288–2.4295)	72.69–72.71 (2.8619–2.8625)
0.50	61.44–61.46 (2.4189–2.4196)	72.44–72.46 (2.8520–2.8527)
0.75	61.19–61.21 (2.4091–2.4098)	72.19–72.21 (2.8422–2.8429)
1.00	60.94–60.96 (2.3992–2.4000)	71.94–71.96 (2.823–2.8330)

UNDER SIZE BEARINGS FOR CRANKSHAFT.

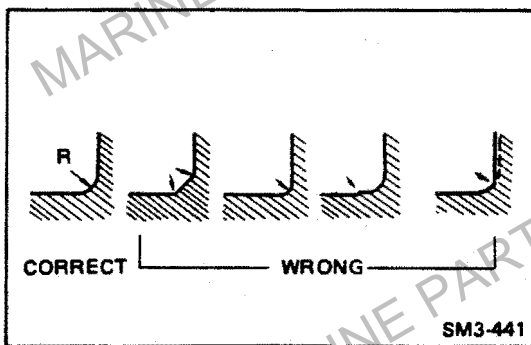

SM3-441

Dimension of Fillet R:

Crank pin: 3.50 – 4.00 mm (0.1378 – 0.1574 in)

Journal : 3.05 – 3.50 mm (0.1201 – 0.1377 in)

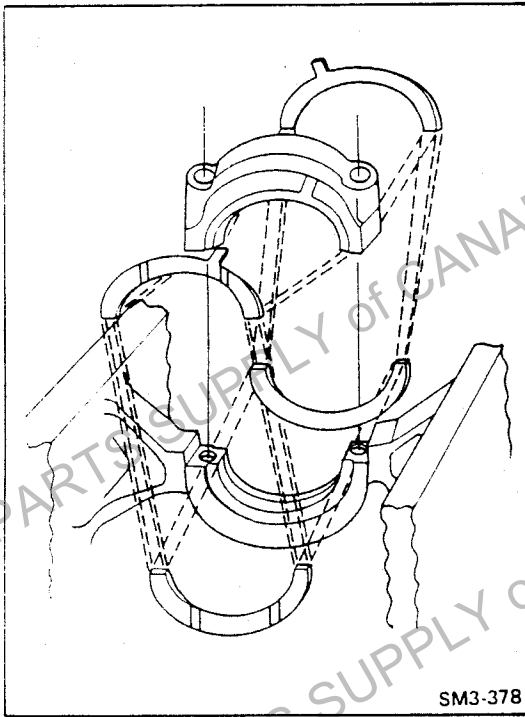

INSTALL THE CRANKSHAFT.

1. Install the crankshaft bearings on the cylinder block and bearing cap.

NOTE: Apply fresh engine oil to each bearing surface.

2. Install the crankshaft on the cylinder block.
3. Insert the crankshaft thrust bearings along the groove of the cylinder block.
4. Install the thrust bearings on the No. 4 bearing cap sides.

NOTE: Apply fresh engine oil to each thrust bearing surface.

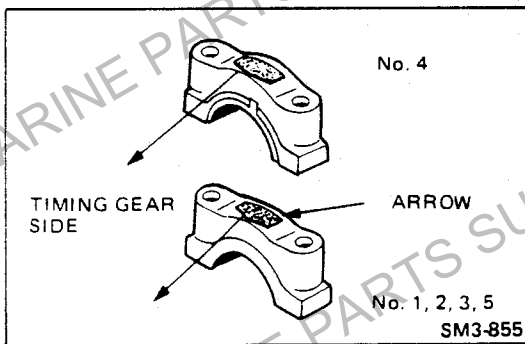

5. Install the crankshaft bearing caps. Install the bearing caps in numbered order from timing gear side with the arrow point toward the timing gear side.

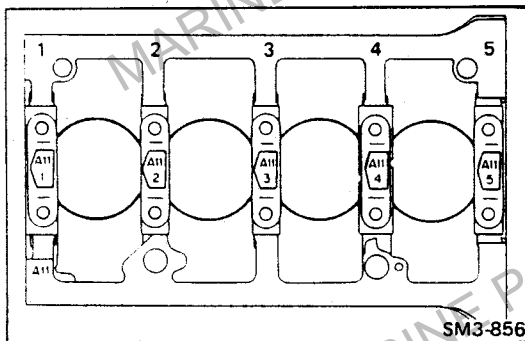

6. Tighten the cap bolts in three stages following the tightening order.

NOTE: Apply engine oil to the bolt threads and under the bolt head.

Tightening order: 3-2-4-1-5

- NOTE:**
- Make sure that the crankshaft rotates smoothly.
 - Inspect the crankshaft end play.

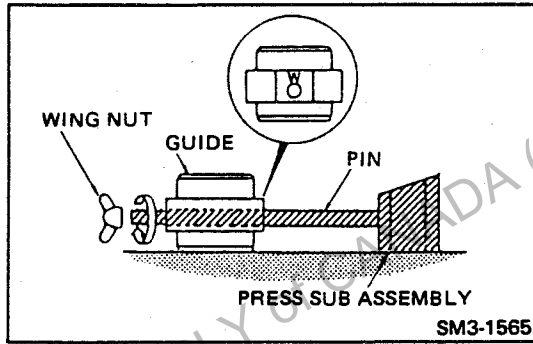

IF NECESSARY, REPLACE THE PISTON PIN BUSHING.

1. Prepare the special tools.

Assemble the guide and press sub assembly inserting its pin into the guide, then secure them with the wing nut.

Special tools: Guide (09481-1130)
Press sub assembly (09402-1450)
Wing nut (9233-10360)

NOTE: ○ Bring letter "W" punched on the guide above the pin.
○ Make sure to align both supporting surface of the guide and press sub assembly flush on a flat plane.

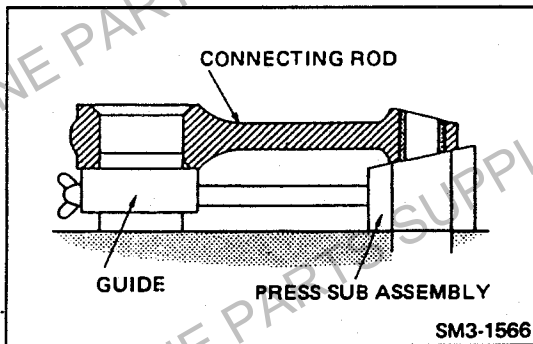

2. Using a special tool, remove the piston pin bushing.

a. Set the connecting rod assembled without crank pin bore bearing on the guide and press sub assembly.

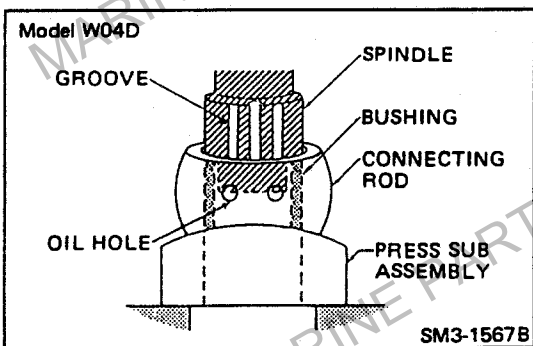

b. Set the spindle on the bushing.

Special Tool: Spindle (09402-1460) for W04D
(09402-1470) for W04C-T and W04C-T1

NOTE: Align the grooving of the spindle with the oil hole of the bushing.

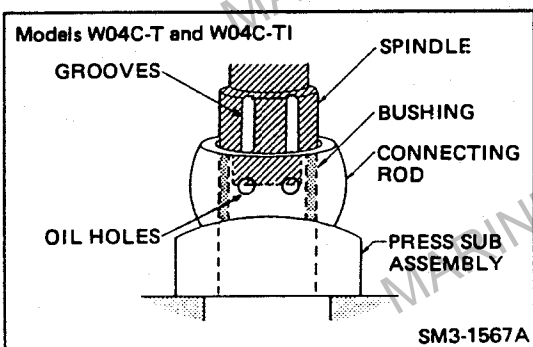

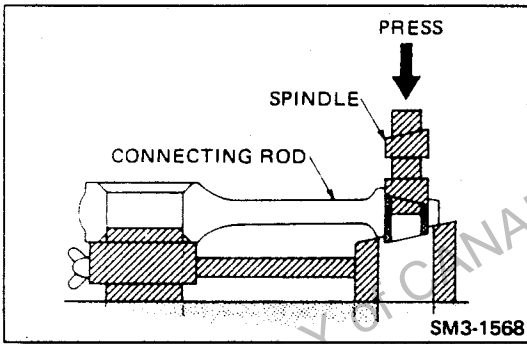

c. Using a hydraulic press, remove the bushing.

NOTE: Always operate the press slowly and smoothly.

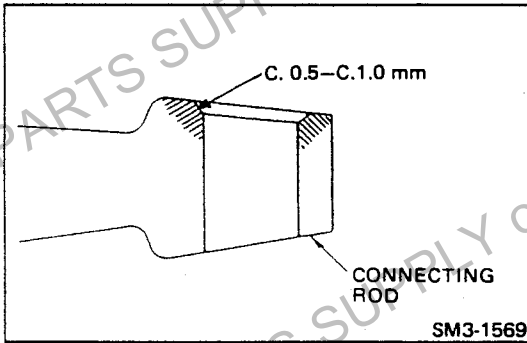

3. Assemble the piston pin bushing.

Chamfer one edge of the bushing hole at the small end of the connecting rod uniformly by C 0.5-1.0 mm (0.0196-0.0393 in).

NOTE:
 ○ Irregular chamfering can cause out-of-roundness of the pressed bushing, which may result in jamming during insertion.
 ○ Remove dust from the inner surface of the small-end hole.

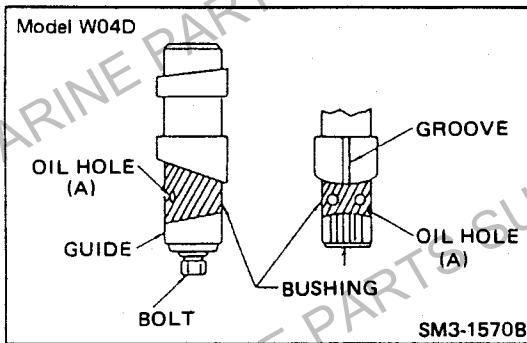

4. Mount the bushing on the spindle.

- a. Set the bushing and guide on the spindle aligning oil hole (A) in the bushing the grooves on the both the spindle and guide.
- b. Secure the bushing and guide with the bolt.

Special Tool: Spindle (09402-1460) for W04D
 (09402-1470) for W04C-T and W04C-TI
 Guide (09481-1120) for W04D
 (09481-1140) for W04C-T and W04C-TI
 Bolt (9191-08252)

NOTE:
 ○ Be sure to slip the bushing over the spindle in the proper direction so that oil hole (A) will later align with the oil path in the connecting rod.
 ○ Apply fresh engine oil to the bushing and guide.

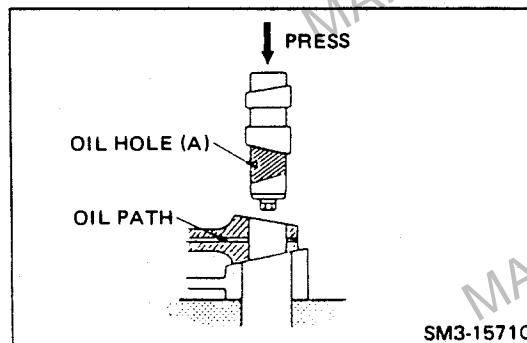
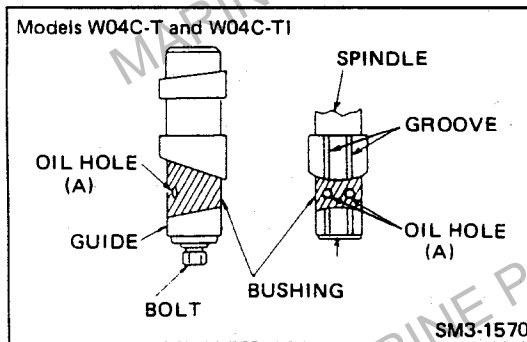

5. Install the bushing in the connecting rod.

Position the bushing—special tool assembly so that oil hole (A) align with the oil path through the connecting rod.

NOTE:
 ○ Fully coat the bore in the connecting rod with fresh engine oil.
 ○ Always operate the press slowly and smoothly.

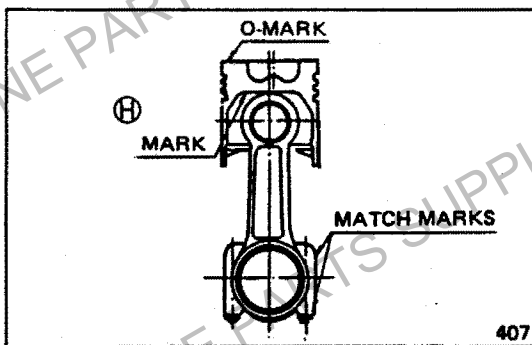
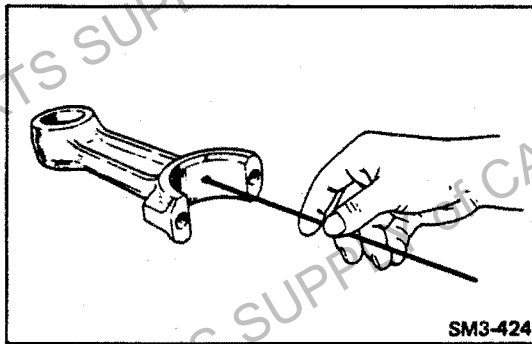
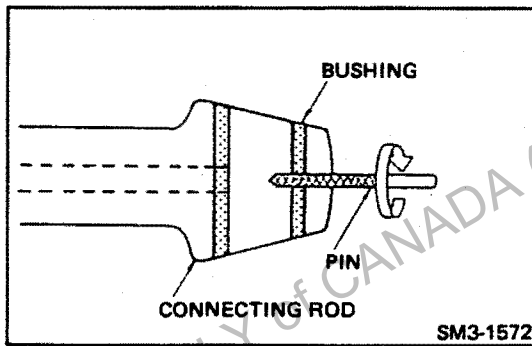

6. Inspect the bushing position after installation.

- NOTE:**
- Make sure that the oil holes of the bushing and connecting rod are aligned.
 - Insert a pin of 3 mm (0.1181 in) dia. into an hole at the end of the connecting rod, and make sure that the pin fully penetrates.
 - If there is any deviation in the alignment of the oil holes correct it with a drill of 3 mm (0.1181 in) dia.
 - Misalignment of the oil holes can lead to insufficient lubrication, which may result in seizure.
 - Insert a new piston pin and rotate it slowly to make sure that there is no rattling.

ASSEMBLE THE PISTON AND CONNECTING ROD.

Make sure that the O-mark at the top of the piston and the connecting rod match marks in opposite directions.

- NOTE:**
- Use the new retainer rings.
 - Heat the piston to 80–90°C (176–194°F) in hot water approx. 5 minutes.

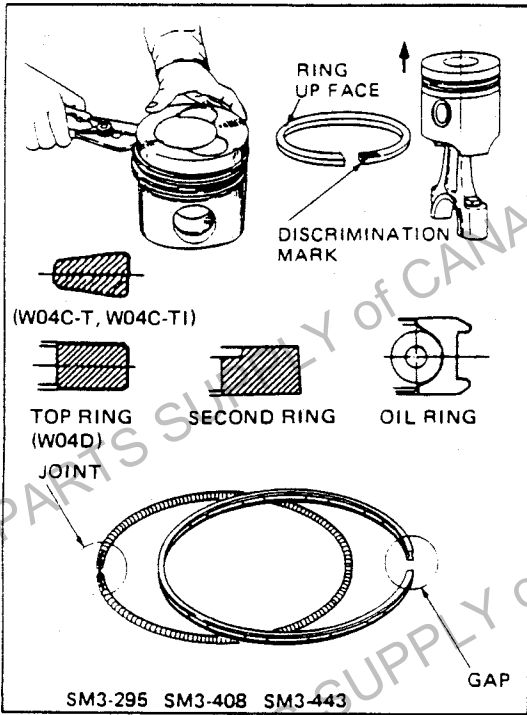

INSTALL THE PISTON RING.

1. Install the piston rings in the sequence oil ring, second ring and top ring with the identification mark at the top of the ring facing up.

NOTE:

- Identification mark of second ring and oil ring is applied with gold paint.
- Apply oil to the piston rings.

Special Tool: Piston Ring Expander (09442-1180)

2. Connect the ends of the coil expander and then fit the coil inside the piston ring after ensuring that the gap of the piston ring is 180° away from the joint of the coil.

3. Arrange the piston rings so that their gaps are equally spaced.

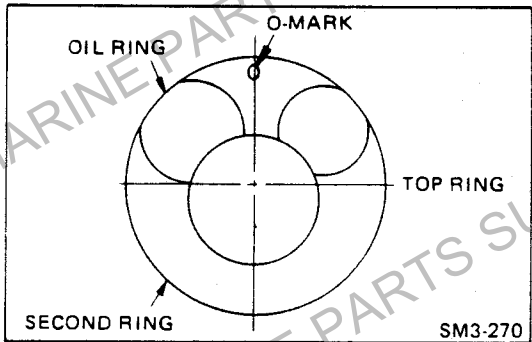

INSTALL THE PISTON IN THE CYLINDER LINER.

1. Apply engine oil to the piston, cylinder liner and connecting rod bearing surface.
2. Using a special tool, hold the piston rings and push the piston with connecting rod assembly with a wooden rod.

NOTE: Check the piston that the O-mark on the top is on the tappet chamber side.

Special Tool: Piston Ring Holder (09441-1260)

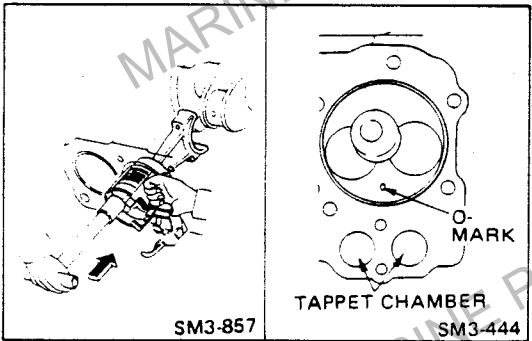

INSTALL THE CONNECTING ROD CAP.

1. Apply engine oil to the cap bearing surface.
2. Align the match marks on the connecting rod and cap.
3. Apply engine oil to the bolt threads and under the bolt head.
4. Tighten the cap bolt in three stages.

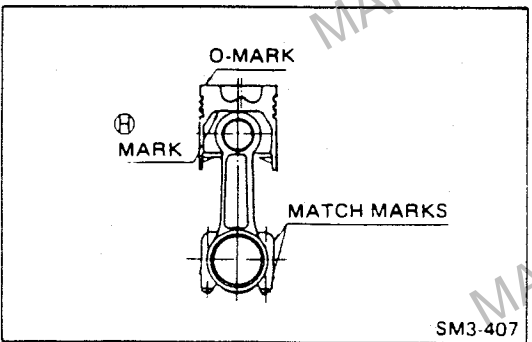

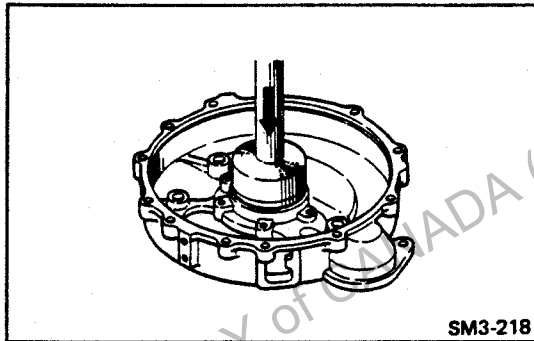

SM3-218

INSTALL THE OIL SEAL IN THE FLYWHEEL HOUSING.

Using a special tool, press in the oil seal in the flywheel housing.

Special Tool: Press (09482-1540)

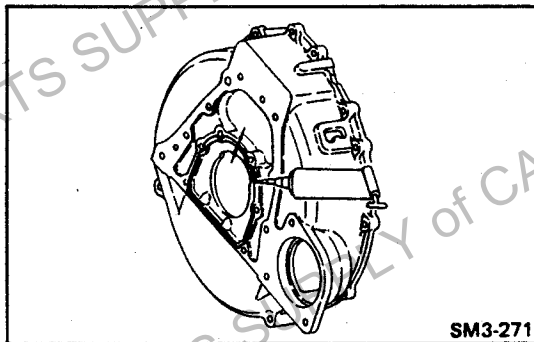

SM3-271

INSTALL THE FLYWHEEL HOUSING.

1. Clean the faces.
2. Apply the liquid gasket as shown and install the flywheel housing within 20 minutes.

NOTE: If leaving it more than 20 minutes, clean the liquid gasket completely and reapply the liquid gasket.

Coating Width: 1.5–2.5 mm (0.06–0.10 in)

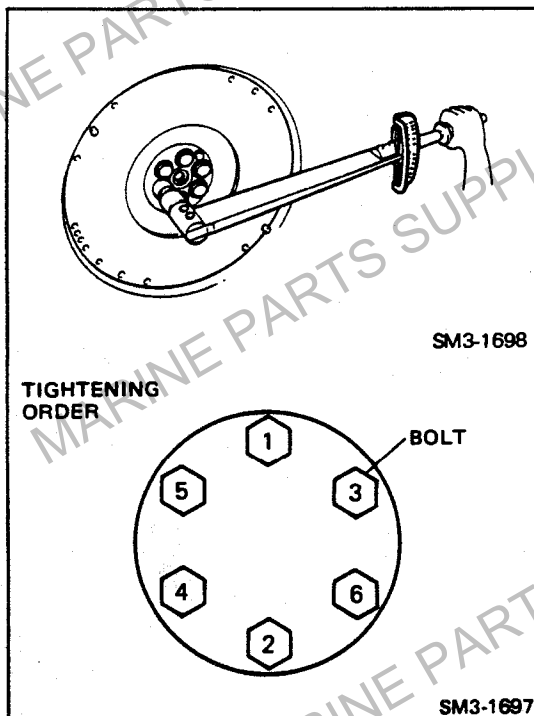

SM3-1698

TIGHTENING
ORDER

BOLT

SM3-1697

INSTALL THE FLYWHEEL.

Install the flywheel and tighten the bolts through several repetitions of the tightening order so as to reach specified torque evenly and gradually, then slacken and tighten them one by one to the specified torque.



- NOTE:**
- Align the "O" mark on the flywheel and crankshaft collar knock-in.
 - When tightening the bolt, apply engine oil to the threads and flywheel surface of the bolts.

INSPECTION AND REPAIR

Unit: mm (in)

Inspection Item		Standard	Limit	Remedy	Inspection Procedure
Piston Diameter		103.860–103.884 (4.0890–4.0899)	—	Replace piston and/or liner	
Cylinder Liner Inside Diameter		104.008–104.040 (4.0949–4.0960)	104.15 (4.1003)		
Clearance between Piston and Cylinder Liner		0.140–0.172 (0.0056–0.0067)	—		
Piston Pin Diameter	W04D	34.989–35.000 (1.3776–1.3779)	34.980 (1.3771)	Replace bushing and/or piston pin	
	W04C-T W04C-TI	36.987–37.003 (1.4562–1.4568)	36.98 (1.4559)		
Piston Pin Hole Inside Diameter	W04D	34.987–35.003 (1.3775–1.3780)	35.02 (1.3787)		
	W04C-T W04C-TI	36.987–37.003 (1.4561–1.4568)	37.02 (1.4574)		
Clearance between Piston Pin and Piston Pin Hole		0.013T–0.014L (0.00052T–0.00055L) T: Tight L: Clearance	0.04 (0.0015)		
Crankshaft end Play		0.05–0.22 (0.0020–0.0086)	0.4 (0.0157)	Replace thrust bearing	
Connecting Rod Small End Bushing Inside Diameter	W04D	35.015–35.025 (1.3786–1.3789)	35.080 (1.3811)	Replace piston end/or piston pin	
	W04C-T W04C-TI	37.015–37.025 (1.4573–1.4575)	37.080 (1.5172)		
Piston Pin Diameter	W04D	34.989–35.000 (1.3776–1.3779)	34.980 (1.3771)		
	W04C-T W04C-TI	36.987–37.003 (1.4562–1.4568)	36.98 (1.4559)		
Clearance between Piston Pin and Connecting Rod Small End Bushing		0.015–0.036 (0.00016–0.0014)	0.1 (0.0039)		

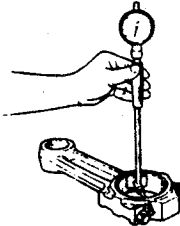
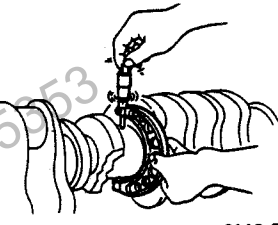
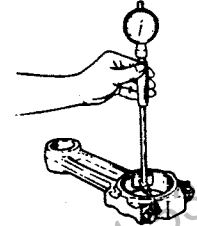
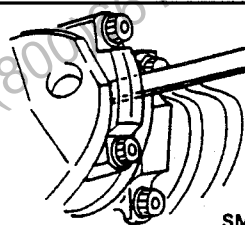
Unit: mm (in)

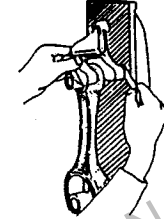
Inspection Item	Standard	Limit	Remedy	Inspection Procedure
Connecting Rod Big end Inside Diameter	65.985—66.000 (2.5979—2.5984)	—	Replace connecting rod assembly	 SM3-300
Connecting Rod Big End Roundness	0.06 (0.0023)	—		
Crank Pin Diameter	61.94—61.96 (2.4386—2.4393)	60.76 (2.3921)	Regrind under size or replace crankshaft	 SM3-860
Clearance between Connecting Rod and Crank Pin	0.031—0.082 (0.0013—0.0032)	0.12 (0.0047)	Replace bearing	 SM3-300
Connecting Rod End Play	0.20—0.52 (0.0079—0.0204)	0.6 (0.0236)	Replace connecting rod	 SM3-862
Connecting Rod Straightness	—	0.1 (0.0039) Per 200 (7.8740)	Replace	 SM3-541
Connecting Rod Twist	—	0.1 (0.0039) Per 200 (7.8740)	Replace	 SM3-542

Unit: mm (in)

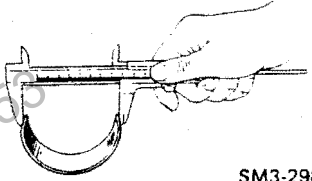
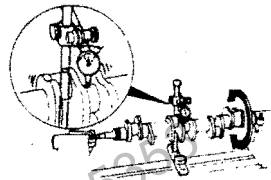
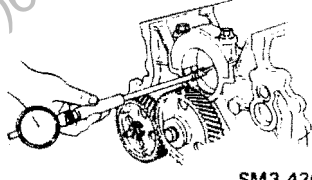
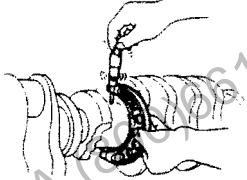
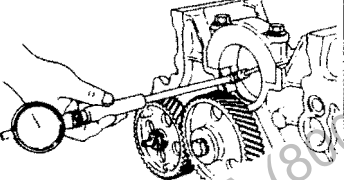
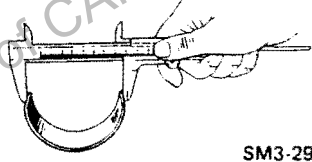
Inspection Item	Standard	Limit	Remedy	Inspection Procedure
Connecting Rod Bearing Sptread Dimension	67.05–67.55 (2.6398–2.6594)	–	Replace	 SM3-298
Crankshaft bearing spread dimension	79.00–79.60 (3.1102–3.1339)	–		
Crankshaft Bend	–	0.04 (0.0015)	Repair or replace	 SM3-861
Crankshaft Main Bearing Cap Roundness	0.06 (0.0023)	–	Repair or replace	 SM3-436
Crankshaft Journal Diameter	72.94–72.96 (2.8717–2.8724)	71.76 (2.8521)	Regrind undersize or replace crankshaft	 SM3-860
Crankshaft main Bearing Inside Diameter	77.985–78.00 (3.0703–0.0708)	–	Replace bearing	 SM3-436
Clearance between Crankshaft Journal and Main Bearing	0.039–0.090 (0.0016–0.0035)	0.13 (0.0051)		
Crankshaft Main Bearing Spread Dimension	79.00–79.06 (3.1103–3.1125)	–	Replace	 SM3-298

Unit: mm (in)

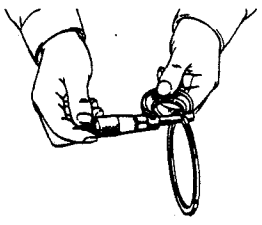
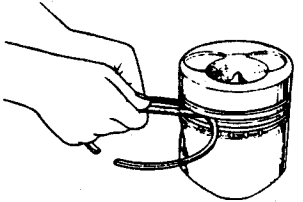
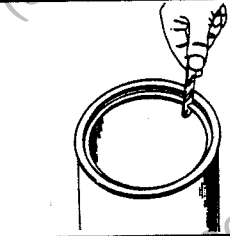
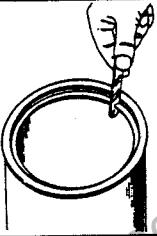
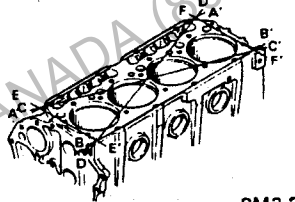
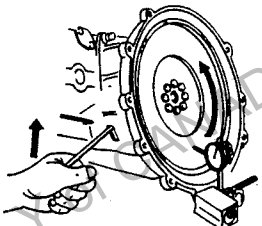
Inspection Item			Standard	Limit	Remedy	Inspection Procedure
Piston Ring Breadth	Top	W04D	2.47–2.49 (0.0972–0.0980)	2.32 (0.0914)	Replace	
		W04C-T W04C-TI	–	–		
	2nd	W04D	1.97–1.99 (0.0776–0.0783)	1.82 (0.0716)		
		W04C-T W04C-TI	2.47–2.49 (0.0972–0.0980)	2.32 (0.0914)		
	Oil		4.97–4.99 (0.1957–0.1964)	4.95 (0.1948)		
Piston Ring Groove Breadth	Top	W04D	2.57–2.59 (0.1012–0.1019)	2.74 (0.1078)	Replace piston ring and/or piston	
		W04C-T W04C-TI	–	–		
	2nd	W04D	2.03–2.05 (0.0800–0.0807)	2.20 (0.0866)		
		W04C-T W04C-TI	2.53–2.55 (0.0996–0.1004)	2.70 (0.1063)		
	Oil		5.01–5.03 (0.1973–0.1980)	5.08 (0.2000)		
Clearance between Piston Ring and Piston Ring Breadth Ring No.:			Top: 0.08–0.12 (0.0032–0.0047) (Model W04D only)	0.3 (0.0118)		
			2nd: 0.04–0.08 (0.0016–0.0031)	0.3 (0.0118)		
			Oil: 0.02–0.06 (0.0008–0.0023)	0.08 (0.0031)		
Piston Ring Gap All Rings: * Insert the Piston Rings Where the Wear of the Liner is Small.			0.3–0.45 (0.0119–0.0177)	1.2 (0.0472)	Replace	
Cylinder Block Flatness			0.05 (0.0019)	0.1 (0.0039)	Regrind and/or replace	
Flywheel Face Alignment			–	0.15 (0.0059)	Regrind and/or replace	

SM3-379

SM3-301

SM3-302

SM3-216

SM3-908

LIQUID GASKET AND APPLICATION POINTS

The W04D, W04C-T and W04C-T1 type engine use liquid gasket (Three Bond TB1207C 04132 1207) instead of conventional sheet gaskets. Apply liquid gasket, therefore, taking the following items into account.

1. LIQUID GASKET APPLICATION POINTS AND COATING WIDTH

Unit: mm (in)

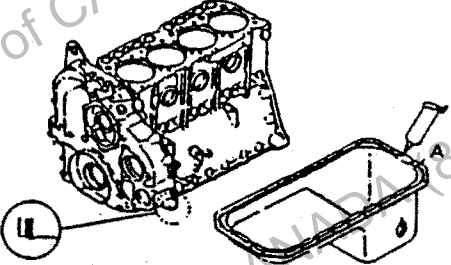
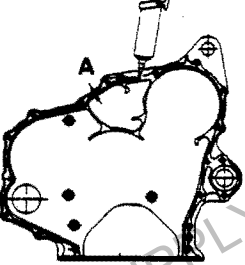
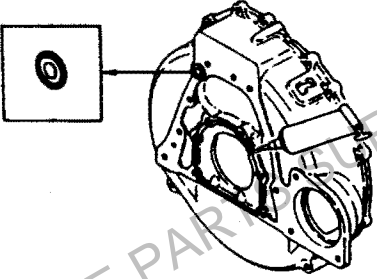
Application point (part)	Portion of engine	Coating width 
(a) Oil pan	Flange face which mates with cylinder block  SM3-214A	3 – 4 (0.12 – 0.16)
(b) Timing gear cover	Faces which mates with gear plate (flange face, boss face)  SM3-247	1.5 – 2.5 (0.06 – 0.10)
(c) Flywheel housing	Faces which mates with cylinder block (flange face, boss face)  SM3-271	1.5 – 2.5 (0.06 – 0.10)

Unit: mm (in)

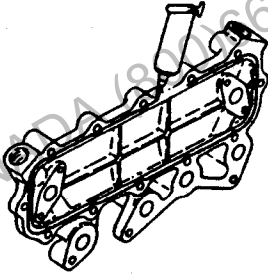
Application point (part)	Portion of engine	Coating width 
(d) Oil cooler	Flange face which mates with cylinder block  SM3-269	1.5 – 2.5 (0.06 – 0.10)
(e) Coolant pump	Flange face which mates with gear cover	1.5 – 2.5 (0.06 – 0.10)
(f) Thermostat case	Flange face which mates with cylinder head	1.5 – 2.5 (0.06 – 0.10)
(g) Seal plate	Flange face which mates with gear cover	1.5 – 2.5 (0.06 – 0.10)
(h) Intake pipe	Flange face which mates with intake manifold	1.5 – 2.5 (0.06 – 0.10)

2. COATING LIQUID GASKET AND PARTS ASSEMBLY PROCEDURE

- (1) Completely remove old liquid gasket from each part and the respective mating part, and remove oil, water, and dirt using a cloth.
- (2) Be careful not to apply excessive or insufficient liquid gasket. Also, be sure to overlap the start and end of each coating.
- (3) When assembling coated parts, be careful that there is no misalignment between mating parts. If there is any misalignment, coat the parts again.
- (4) Assemble the various parts within 20 minutes after applying liquid gasket. If more than 20 minutes have elapsed, remove the liquid gasket and apply it again.
- (5) After assembling the various parts, wait for at least 15 minutes before starting the engine.

3. REMOVING PARTS

When removing each part, do not attempt to pry one portion of the flange alone but use the flange collar or clearance to pry the flange at several points alternately.

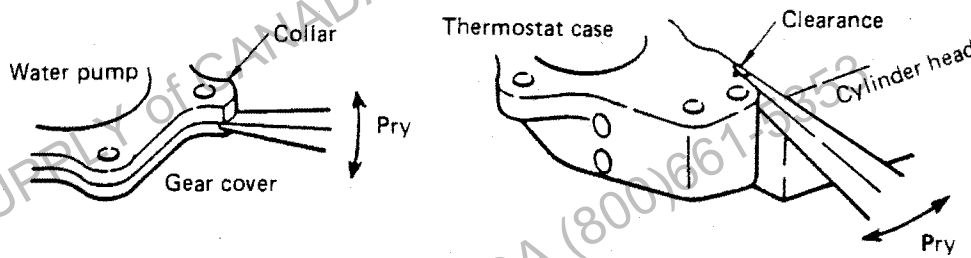

4. GEAR PLATE GASKET

When replacing the gear plate gasket, cut it so that no steps are formed in it, then liberally apply liquid gasket to the cut face and assemble the oil pan.

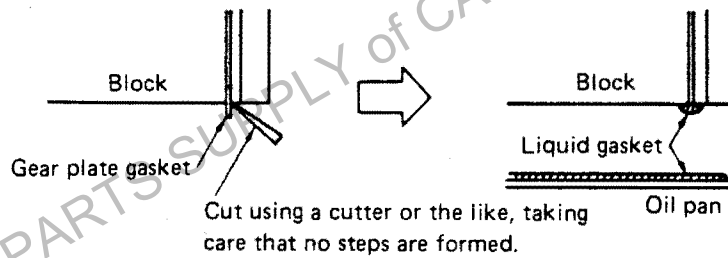

NOTE: The flange of the oil pan may sometimes become deformed preventing it from being reused. To prevent this, therefore, first insert plates with a thin edge at several points around the periphery of the oil pan, then remove the oil pan using a screwdriver.

LUBRICATING SYSTEM

DATA AND SPECIFICATIONS

Oil pump	
Type	Full forced pressure feed by gear pump
Drive	By gear
Oil cooler	
Type	Multi plates type, water-cooled

LUBRICATING SYSTEM DIAGRAM

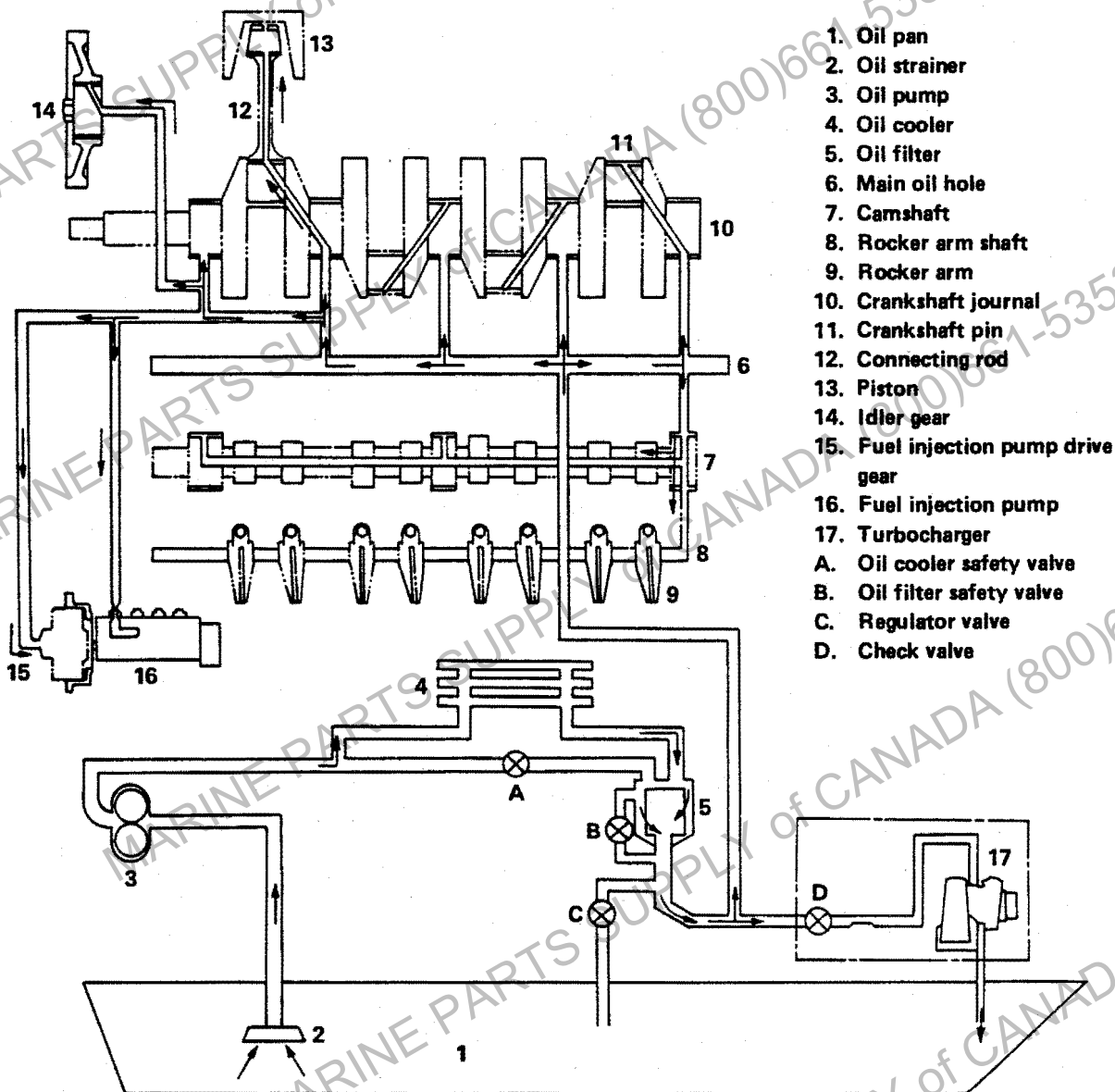

1. Oil pan
2. Oil strainer
3. Oil pump
4. Oil cooler
5. Oil filter
6. Main oil hole
7. Camshaft
8. Rocker arm shaft
9. Rocker arm
10. Crankshaft journal
11. Crankshaft pin
12. Connecting rod
13. Piston
14. Idler gear
15. Fuel injection pump drive gear
16. Fuel injection pump
17. Turbocharger
- A. Oil cooler safety valve
- B. Oil filter safety valve
- C. Regulator valve
- D. Check valve

SM3-1820

OVERHAUL

HE11-040-00X07 (1400)
X20

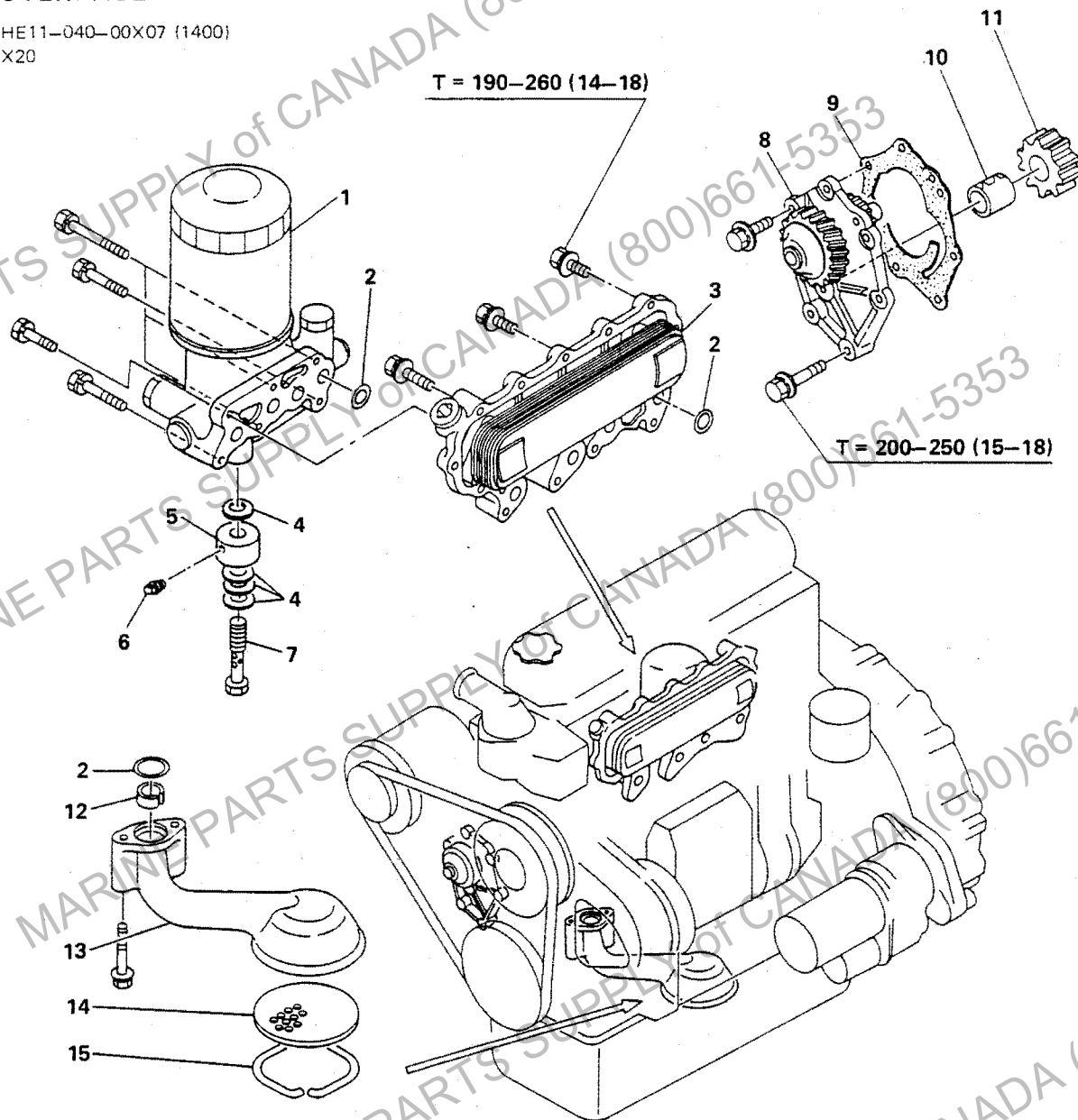

T = Tightening torque: kg-cm (lb.ft)

- 1. Oil filter
- 2. O-ring
- 3. Oil cooler
- 4. Soft washer
- 5. Connector pipe

- 6. Plug
- 7. Connector bolt
- 8. Oil pump cover subassembly
- 9. Gasket
- 10. Bushing

- 11. Oil pump driven gear
- 12. O-ring guide
- 13. Oil strainer
- 14. Oil strainer screen
- 15. Snap ring

OIL PUMP

DESCRIPTION

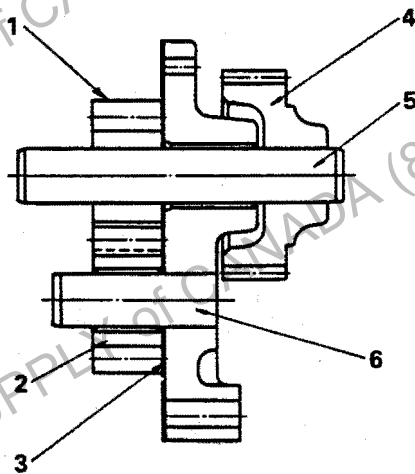

1. Drive gear (Inside)
2. Driven gear
3. Gasket
4. Drive gear (Outside)
5. Drive shaft
6. Driven shaft

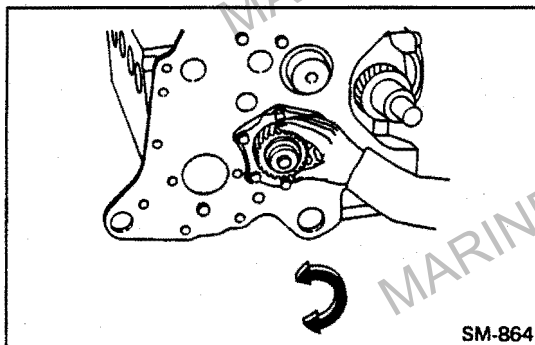
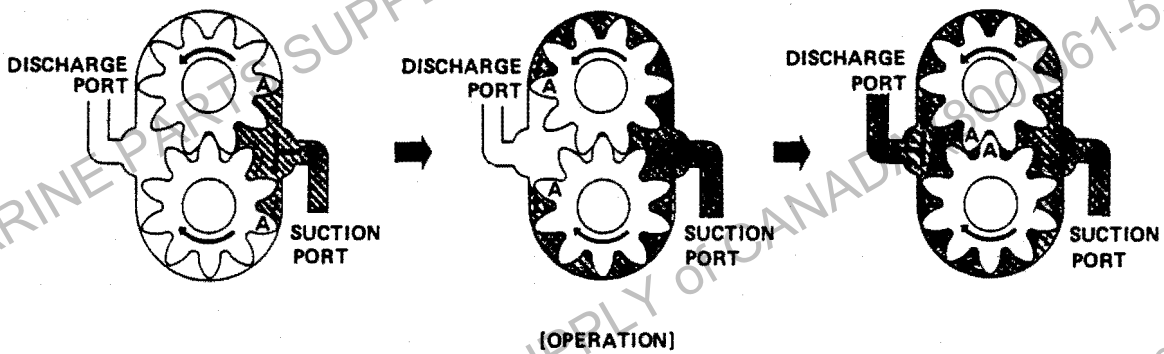



IMPORTANT POINT – MOUNTING

INSTALL THE OIL PUMP.

1. Apply oil liberally to cylinder block pump case and bearing before installing oil pump.
2. Confirm smooth rotation of oil pump after tightening bolts.

INSPECTION AND REPAIR

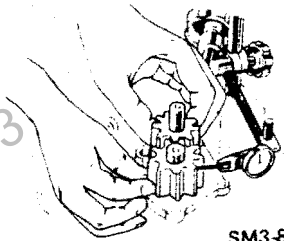
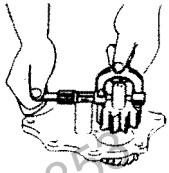
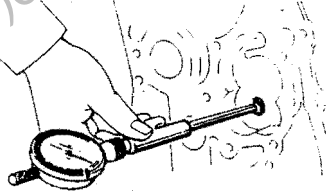
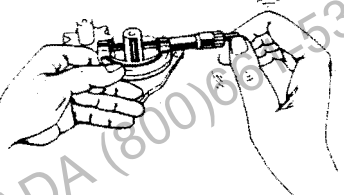
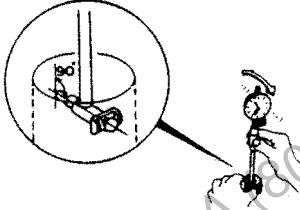
Unit: mm (in)

Inspection Item	Standard	Limit	Remedy	Inspection Procedure
Gear Backlash	0.09–0.21 (0.0036–0.0082)	0.30 (0.0118)	Replace gear	 SM3-867
Drive Gear Shaft Diameter	18.088–18.106 (0.7122–0.7128)	18.060 (0.7110)	Replace	 SM3-870
Drive Shaft Bearing Inside Diameter	18.146–18.173 (0.7145–0.7154)	18.20 (0.7165)	Replace	
Clearance between Drive Shaft and Bearing	0.040–0.085 (0.0080–0.0033)	0.1 (0.0039)	Replace bearing and/or shaft	 SM3-1070
Driven Gear Shaft Diameter	17.979–17.997 (0.7079–0.7085)	17.970 (0.7074)	Replace	 SM3-868
Driven Gear Inside Diameter	18.037–18.054 (0.7102–0.7107)	18.070 (0.7114)	Replace	
Clearance between Driven Gear and Shaft	0.040–0.075 (0.0080–0.0023)	0.1 (0.0039)	Replace bearing and/or shaft	 SM3-869
Gear Teeth Pitting or Wear	–	–	Replace, if necessary	Visual check  SM3-845

OIL COOLER AND OIL FILTER

SPECIAL TOOL

Prior to starting an engine overhaul, it is necessary to have these special tools.

WRENCH

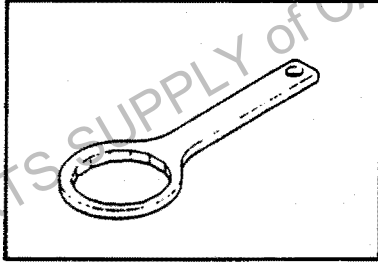

09553-1010

For spin-on type oil filter

OVERHAUL

1419M
I-No.21

1425G
I-No. 20

T = 250-350 (19-25)

T = 100-150 (8-10)

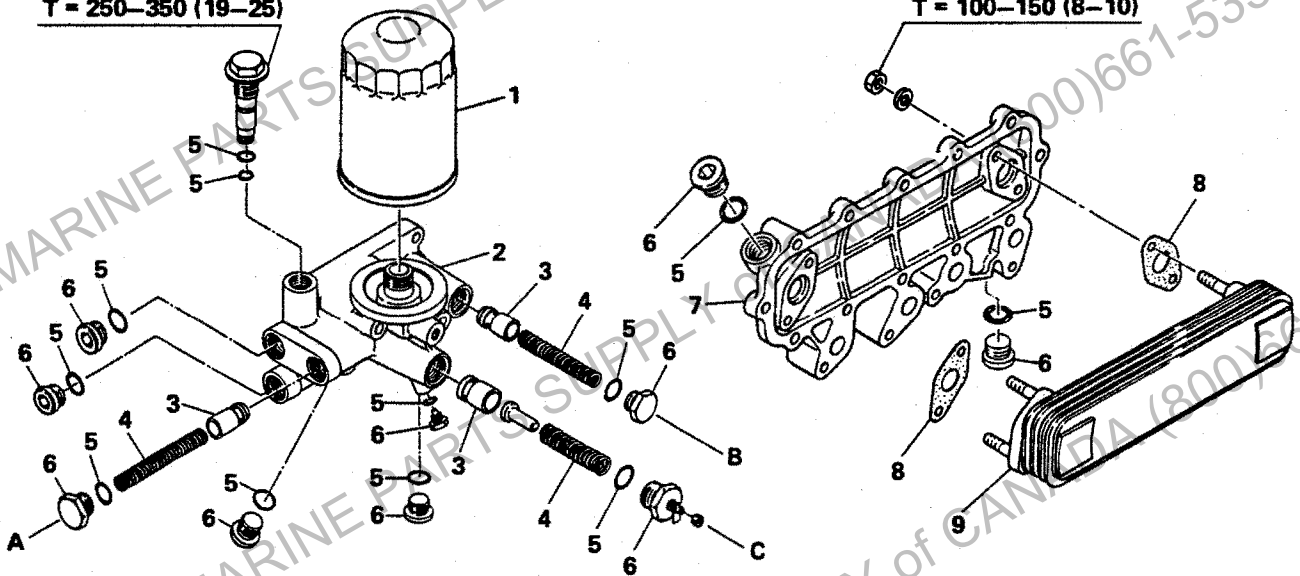

T = Tightening torque: kg-cm (lb.ft)

1. Oil filter
2. Oil filter cover
3. Valve
4. Spring
5. O-ring
6. Plug

7. Oil cooler case
8. Gasket
9. Oil cooler element

- A. Oil filter safety valve
1.3 kg/cm² (18.5 lb/sq.in)
- B. Oil cooler safety valve
4.0 kg/cm² (56.9 lb/sq.in)
- C. Regulator valve
4.0 kg/cm² (56.9 lb/sq.in)

IMPORTANT POINT — DISMOUNTING

REMOVE THE SPIN-ON TYPE OIL FILTER.

Using a special tool, unscrew the oil filter.

Special Tool: Wrench (09553-1010)

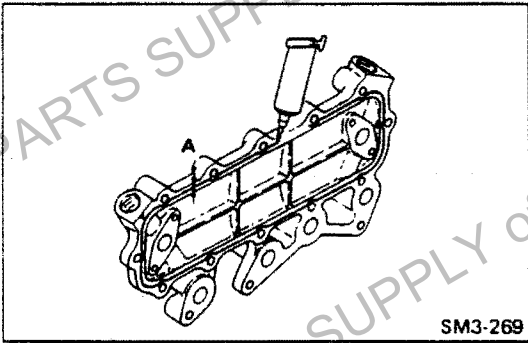

IMPORTANT POINTS — MOUNTING

INSTALL THE OIL COOLER.

1. Clean the faces.
2. Apply the liquid gasket as shown and install the oil cooler within 20 minutes.

NOTE: If leaving it more than 20 minutes, clean the liquid gasket completely and reapply the liquid gasket.

Coating Width (A): 1.5–2.5 mm (0.06–0.10 in)

INSTALL THE SPIN-ON TYPE OIL FILTER.

1. Apply a slight amount of engine oil to the gasket of the new filter.
2. Tighten the new filter by hand until the gasket touches the cover and the tighten another 3/4 to 1 full turn with a special tool.

Special Tool: Wrench (09553-1010)

INSPECTION AND REPAIR

Inspection Item	Standard	Limit	Remedy	Inspection Procedure
Valve and Springs of Oil Filter. Wear or Damage.	—	—	Replace, if necessary.	Visual check

FUEL SYSTEM

DATA AND SPECIFICATIONS

Injection nozzle

Type	Multi-hole nozzle type
Opening pressure	220 kg/cm ² (3,129 lb/sq.in)

FUEL SYSTEM DIAGRAM

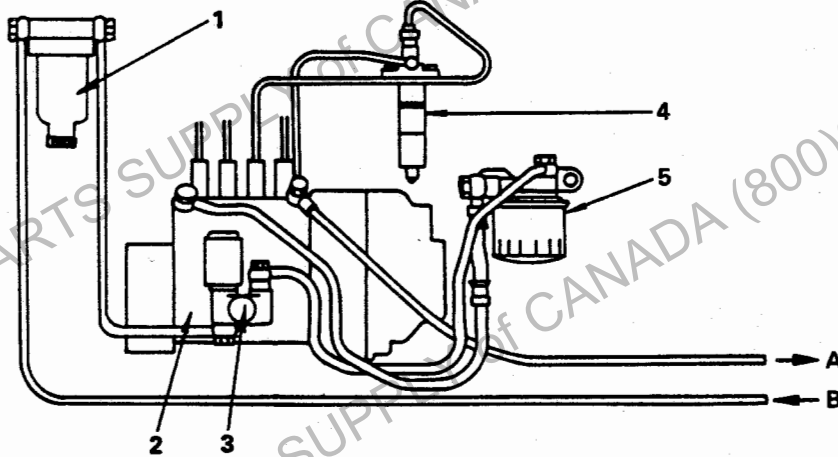

1. Water separator
(If so equipped)
2. Fuel injection pump
3. Fuel feed pump
4. Injection nozzle
5. Fuel filter
- A. To fuel tank
- B. From fuel tank

SM3-227A

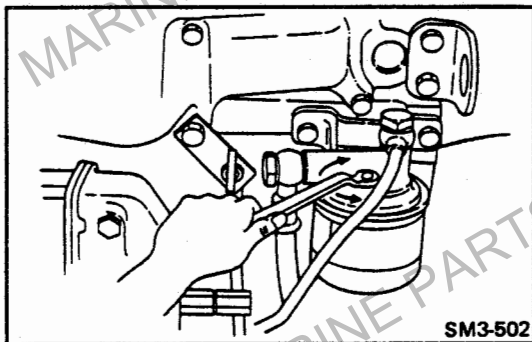

SM3-502

AIR BLEEDING FROM FUEL SYSTEM.

1. Loosen the bleeder plug on the fuel filter.
2. Loosen the priming pump knob.
3. Operate the priming pump knob until the air will not come out from the bleeder plug.
4. Tighten the bleeder plug.

Tightening Torque: 40–60 kg-cm (3–4 lb.ft)

NOTE: The bleeder plug should be tightened while the priming pump knob is operated.

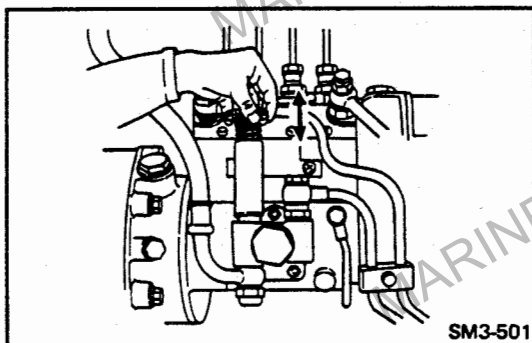

SM3-501

5. Push back the priming pump knob and tighten it.

NOTE: Wipe off any splashed fuel.

COOLING SYSTEM

DATA AND SPECIFICATIONS

Coolant pump	
Type	Forced circulation by volute pump
Drive	By V-belt
Seawater pump	
Type	Self priming type (Flexible impeller pump)
Drive	By gear
Thermostat	
Type	Wax type, bottom bypass system
Valve opening temperature	76.5°C (170°F)

COOLING SYSTEM DIAGRAM

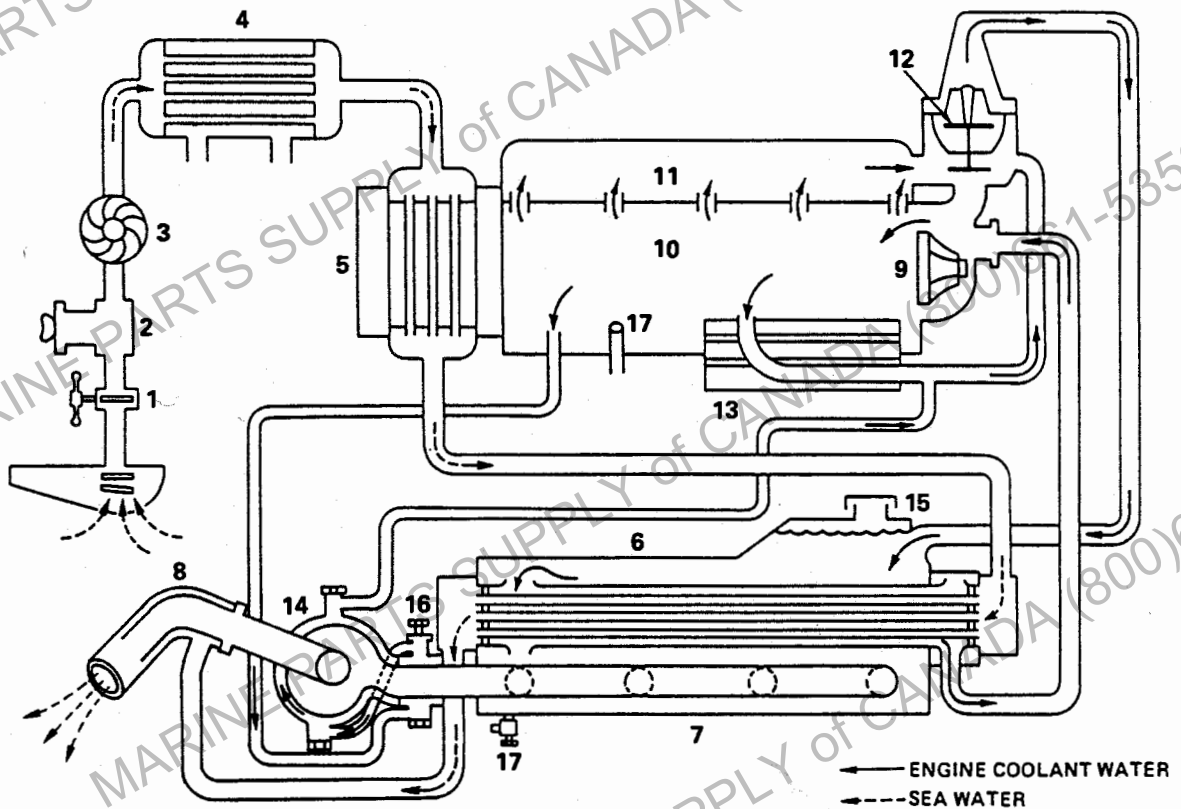

SM3-1854

- | | | |
|------------------------------------|----------------------------------|-------------------------------|
| 1. Seawater intake valve (Seacock) | 7. Water cooled exhaust manifold | 13. Engine oil cooler |
| 2. Seawater filter | 8. Exhaust pipe | 14. Water cooled turbocharger |
| 3. Seawater pump | 9. Coolant pump | 15. Coolant filler cap |
| 4. Intercooler | 10. Cylinder block | 16. Air bleeder plug |
| 5. Transmission fluid cooler | 11. Cylinder head | 17. Coolant drain plug |
| 6. Heat exchanger | 12. Thermostat | |

OVERHAUL

HE11-038-00X0

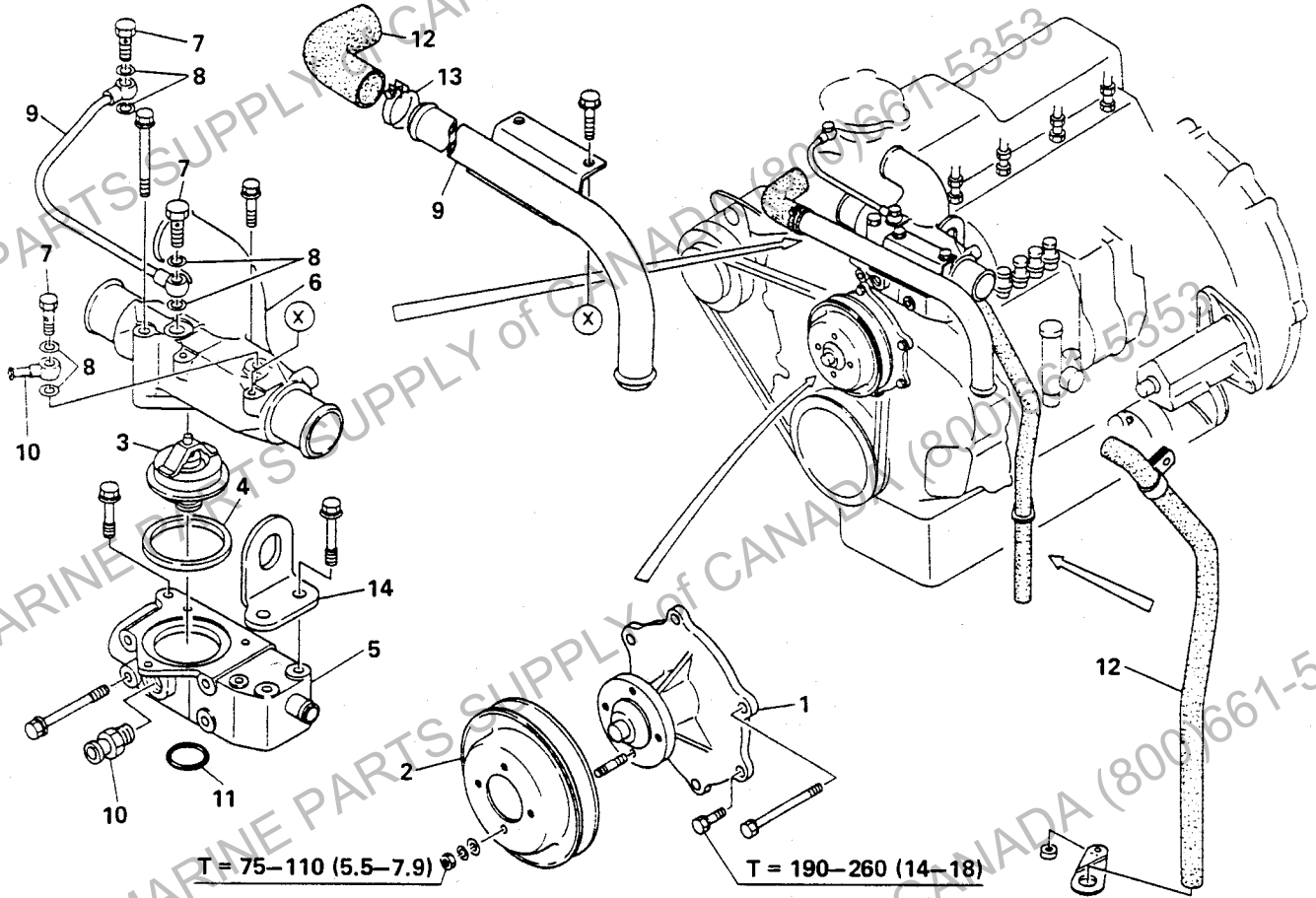

T = 75-110 (5.5-7.9)

T = 190-260 (14-18)

T = Tightening torque: kg-cm (lb.ft)

- 1. Coolant pump
- 2. Coolant pump pulley
- 3. Thermostat
- 4. Thermostat gasket
- 5. Thermostat case
- 6. Coolant manifold
- 7. Connector bolt
- 8. Soft washer
- 9. Pipe
- 10. Connector
- 11. O-ring
- 12. Hose
- 13. Clamp
- 14. Engine hanger

COOLANT PUMP

OVERHAUL

1659N
I-No. 21

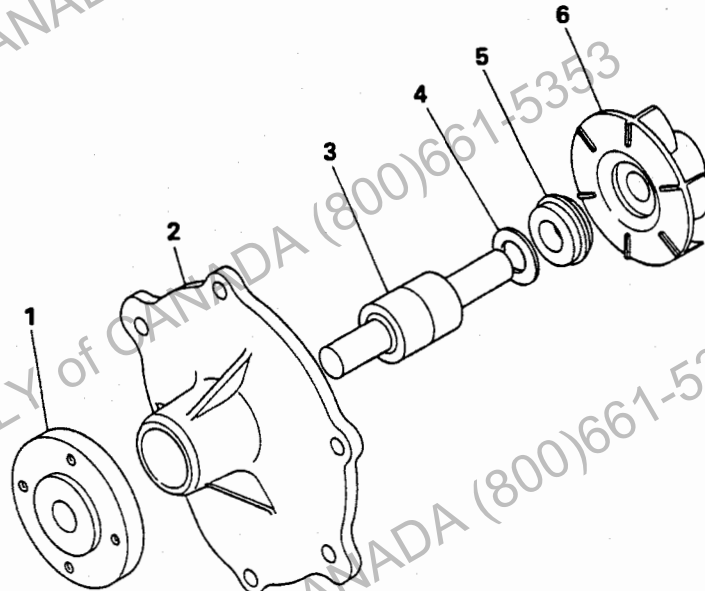

1. Pulley center
2. Pump case
3. Shaft subassembly

4. Slinger
5. Coolant seal
6. Vane

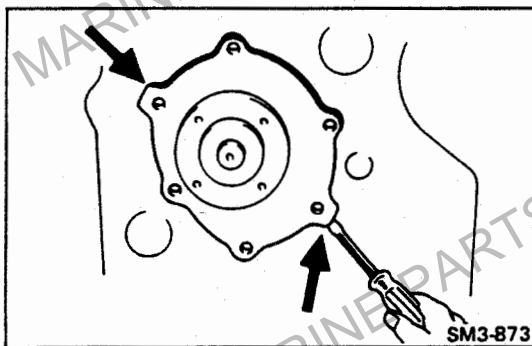

IMPORTANT POINT – DISMOUNTING

REMOVE BY PRYING LOOSE WITH SCREWDRIVER AT THE 2 POINTS ON THE FLANGE.

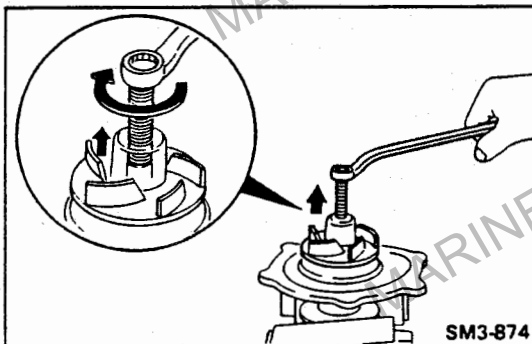

IMPORTANT POINTS – DISASSEMBLY

REMOVE VANE FROM SHAFT BY SCREWING IN A BOLT.

Bolt Size;

Diameter: 10 mm (0.394 in)

Pitch: 1.5 mm (0.059 in)

USING A PULLER, REMOVE THE PULLY CENTER FROM THE SHAFT.

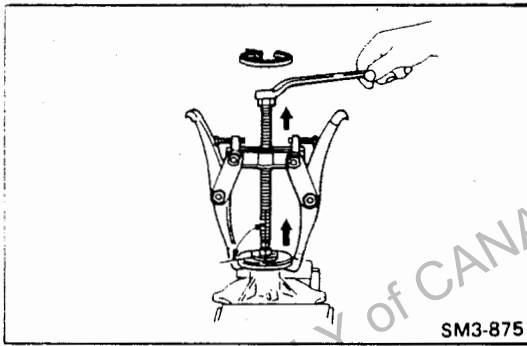

SM3-875

USING A STEEL PIPE AND PRESS, REMOVE THE SHAFT FROM BODY.

Steel Pipe Dimention: A: More than 57 mm (2.244 in)
 B: 18 – 21 mm (0.7087 – 0.8267 in)
 C: Less than 29.5 mm (1.161 in)

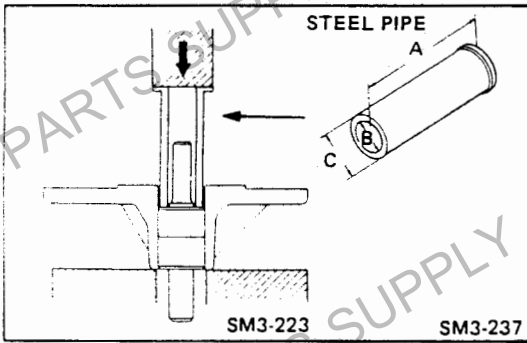

SM3-223

SM3-237

IMPORTANT POINTS – ASSEMBLY

USING A STEEL PIPE AND PRESS, INSTALL THE SHAFT TO THE CASE.

NOTE: Bearing face must be aligned with edge of body.

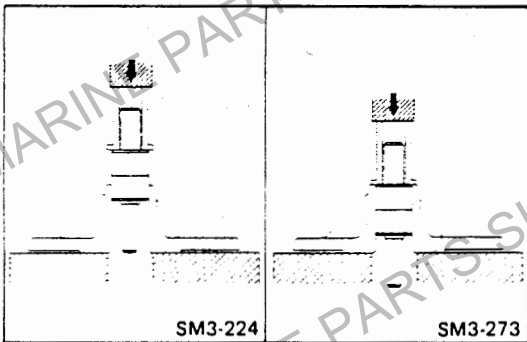

SM3-224

SM3-273

USING A PRESS, INSTALL THE PULLEY CENTER.

DIMENSION (A): 61.5 mm (2.421 in) for W04D, W04C-T
 90 mm (3.543 in) for W04C-T1

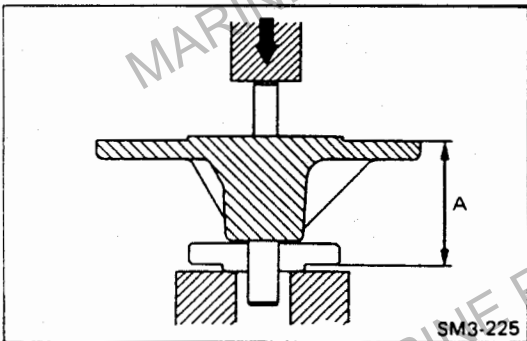

SM3-225

INSTALL THE NEW COOLANT SEAL.

1. Apply a little liquid sealer to the coolant seal outer circumference and coolant pump body.
2. Install the slinger and coolant seal.

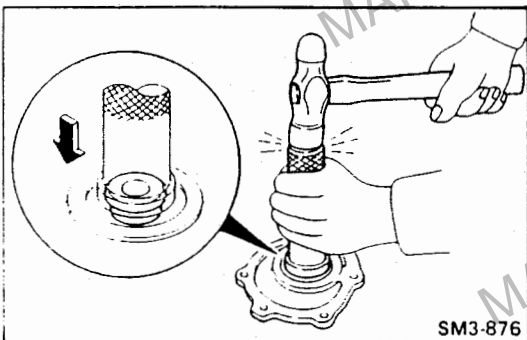

SM3-876

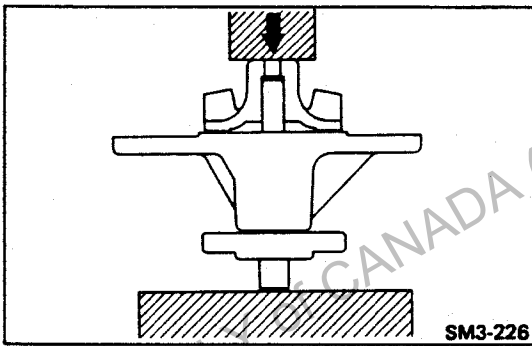

SM3-226

USING A PRESS, INSTALL THE VANE TO THE SHAFT.

NOTE: Apply a little engine oil to the coolant seal face.

AFTER THE COOLANT PUMP HAS BEEN ASSEMBLED, CHECK THAT THE SHAFT ROTATES SMOOTHLY.

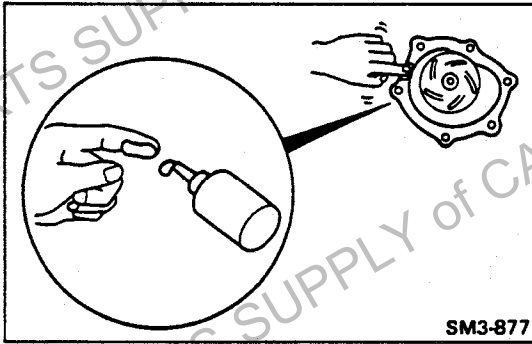

SM3-877

IMPORTANT POINT – MOUNTING

INSTALL THE COOLANT PUMP TO THE TIMING GEAR COVER.

1. Clean the contacting surface of the coolant pump and timing gear cover free of old sealer, water and oil.
2. Apply the liquid gasket as shown and install the coolant pump within 20 minutes.

NOTE: If leaving it more than 20 minutes, clean the liquid gasket completely and reapply the liquid gasket.

Coating Width: 1.5–2.5 mm (0.06–0.10 in)

HEAT EXCHANGER

DESCRIPTION

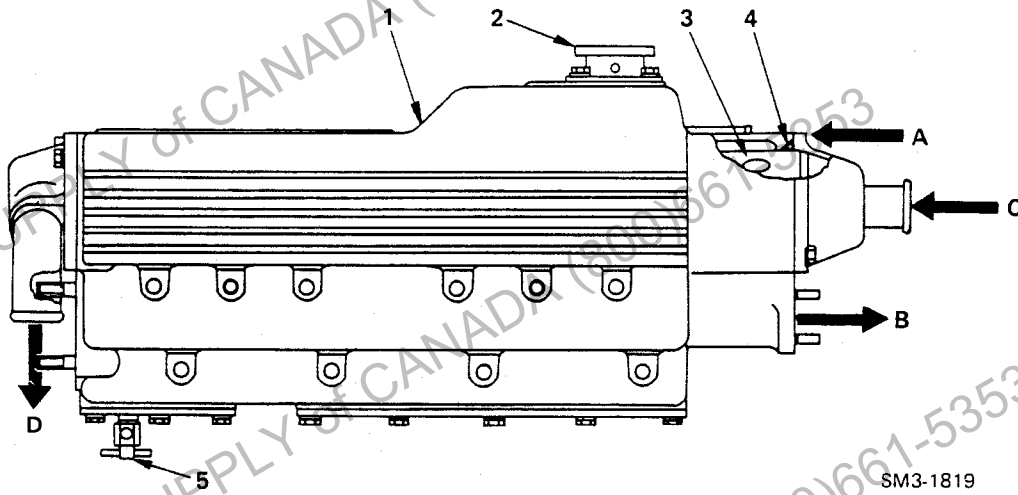

OVERHAUL

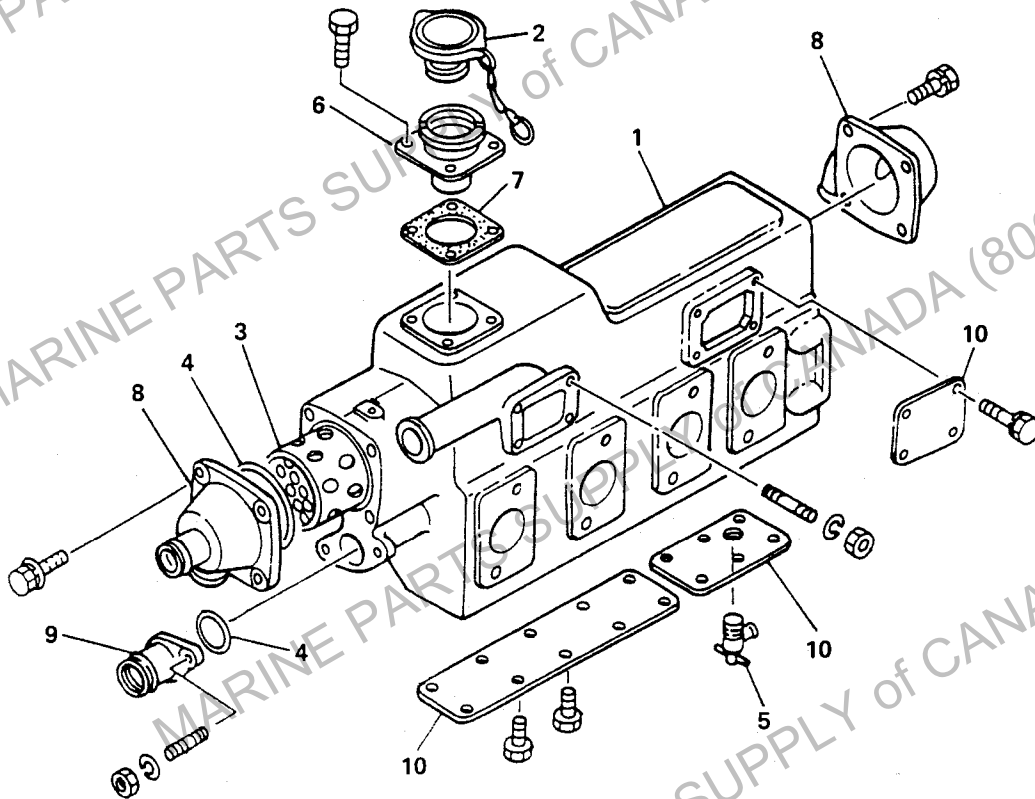

- 1. Housing
- 2. Cap
- 3. Element
- 4. O-Ring
- 5. Engine coolant drain cock

- 6. Filler pipe seat
- 7. Gasket
- 8. Water gallery cover
- 9. Coolant pipe
- 10. Plate

- A. Engine coolant inlet
- B. Engine coolant outlet
- C. Seawater inlet
- D. Seawater outlet

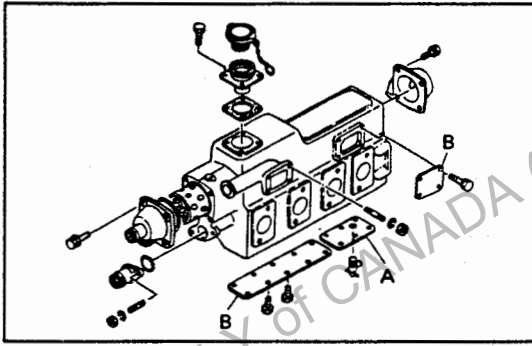



IMPORTANT POINTS – ASSEMBLY

ASSEMBLE THE HEAT EXCHANGER.

- NOTE:**
- Replace the O-rings and gasket with new ones.
 - Before installing the plates "A" and "B", apply sealing compound (Three bond No. T6-1207C or equivalent).
 - When installing the plate "A" on the heat exchanger, the "O" mark should face outside.

INSPECTION AND REPAIR

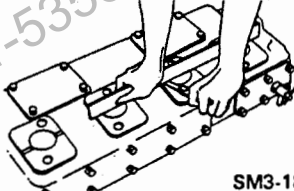
Unit: mm (in)

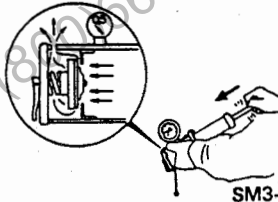
Inspection Item	Standard	Limit	Remedy	Inspection Procedure
Exhaust Manifold. Flatness	Less than 0.1 (0.0039)	0.5 (0.019)	Resurface or replace.	 SM3-1858
Element. Clogged.	—	—	Clean with compressed air or sodium hydroxide	 SM3-1800
Heat exchanger cap valve opening pressure.	0.4–0.6 kg/cm ² (5.7–8.5 lb/sq.in)	—	Replace	 SM3-823

THERMOSTAT

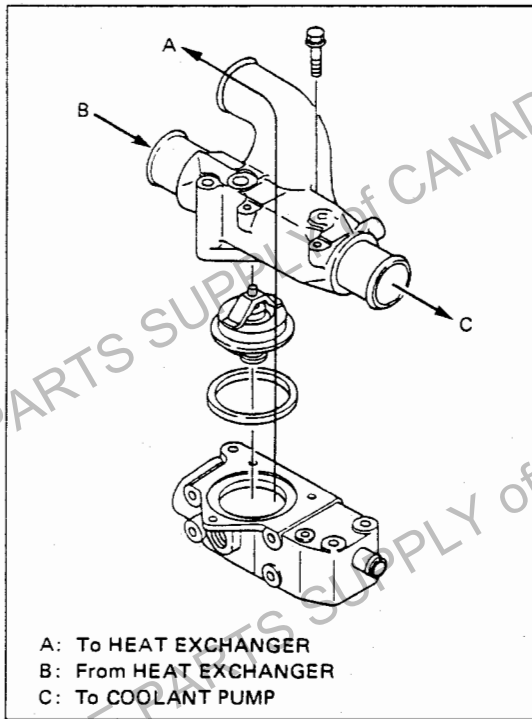

IMPORTANT POINT – MOUNTING

INSTALL THE THERMOSTAT.

1. Remove water and dirt adhering to the thermostat case.
2. Replace the gasket without fail if it is corroded, damaged or flattened.
3. Before installing the thermostat, apply sealing compound to the hose installation portion of the coolant manifold.
4. Assemble the thermostat, gasket, case and coolant manifold as shown.

INSPECTION AND REPAIR

Unit: mm (in)

Inspection Item	Standard	Limit	Remedy	Inspection Procedure
Thermostat Valve Opening Temperature	74.5–78.5°C (166–173°F)	—	Replace thermostat	
Thermostat Valve Lift	At least 10 (0.4) at 90°C (194°F)	—		
Thermostat Closing Condition	Fully opened valve should close completely within 5 minutes when thermostat is immersed in water of normal temperature.	—		

SM3-888

AIR INTAKE AND EXHAUST SYSTEM

OVERHAUL

ME11-040-00X07 (1320)

Model W04D

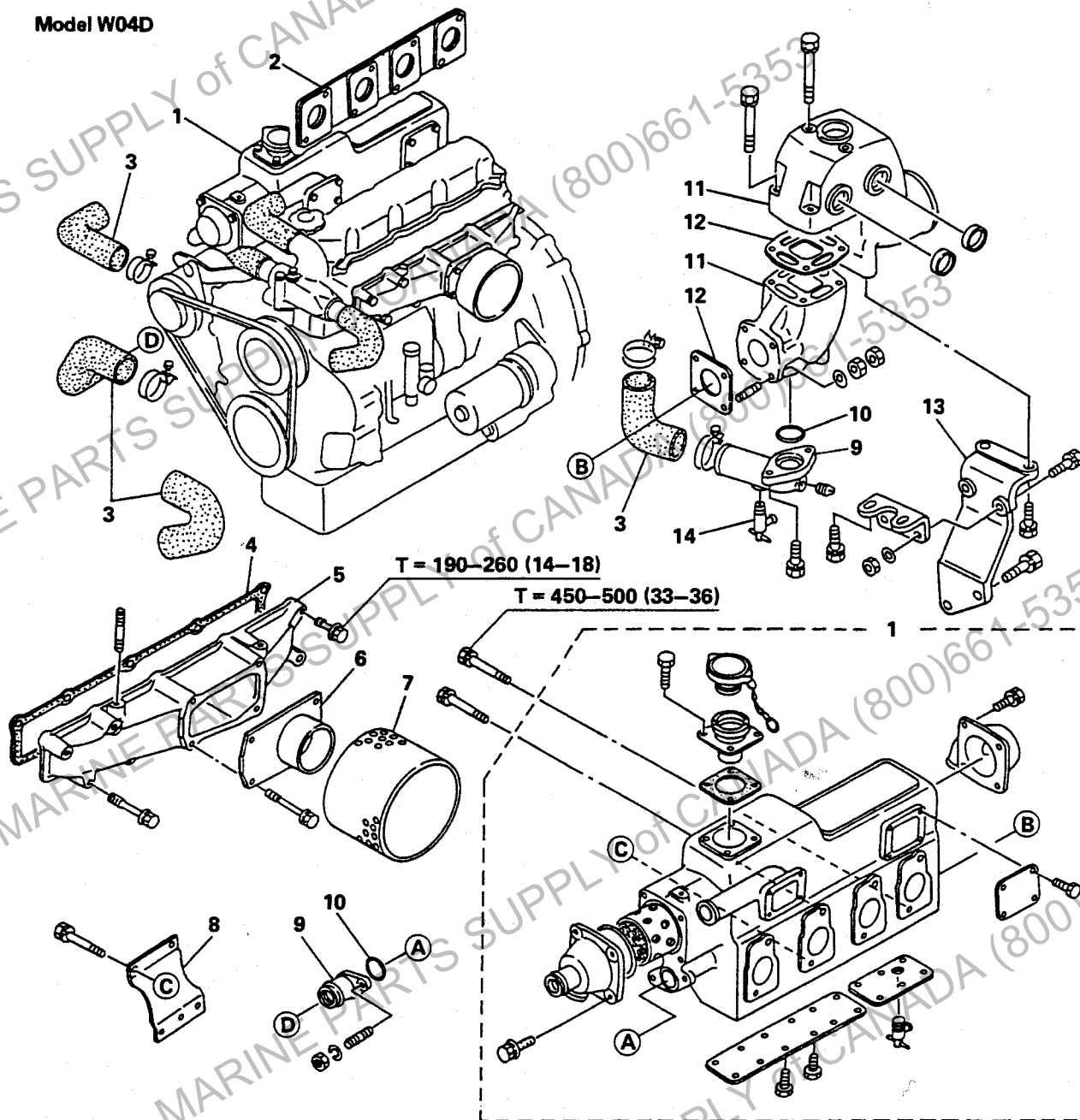

T = Tightening torque: kg-cm (lb.ft)

SM3-1837

1. Heat exchanger (Exhaust manifold)
2. Exhaust manifold gasket
3. Water hose
4. Intake manifold gasket
5. Intake manifold
6. Intake pipe
7. Air cleaner

8. Heat exchanger bracket
9. Water pipe
10. O-ring
11. Exhaust pipe
12. Gasket
13. Exhaust pipe bracket
14. Drain cock

OVERHAUL

HE11-038-00X03

Model W04C-T

1. Heat exchanger (Exhaust manifold)
2. Exhaust manifold gasket
3. Water hose
4. Clamp
5. O-ring
6. Water pipe
7. Engine coolant drain cock
8. Intake manifold gasket
9. Intake manifold
10. Intake air pipe
11. Oil pipe
12. Soft washer
13. Air bleeder plug
14. Engine coolant drain plug
15. Gasket
16. Turbocharger
17. Air hose
18. Air cleaner
19. Exhaust pipe
20. Exhaust pipe bracket
21. Heat exchanger bracket

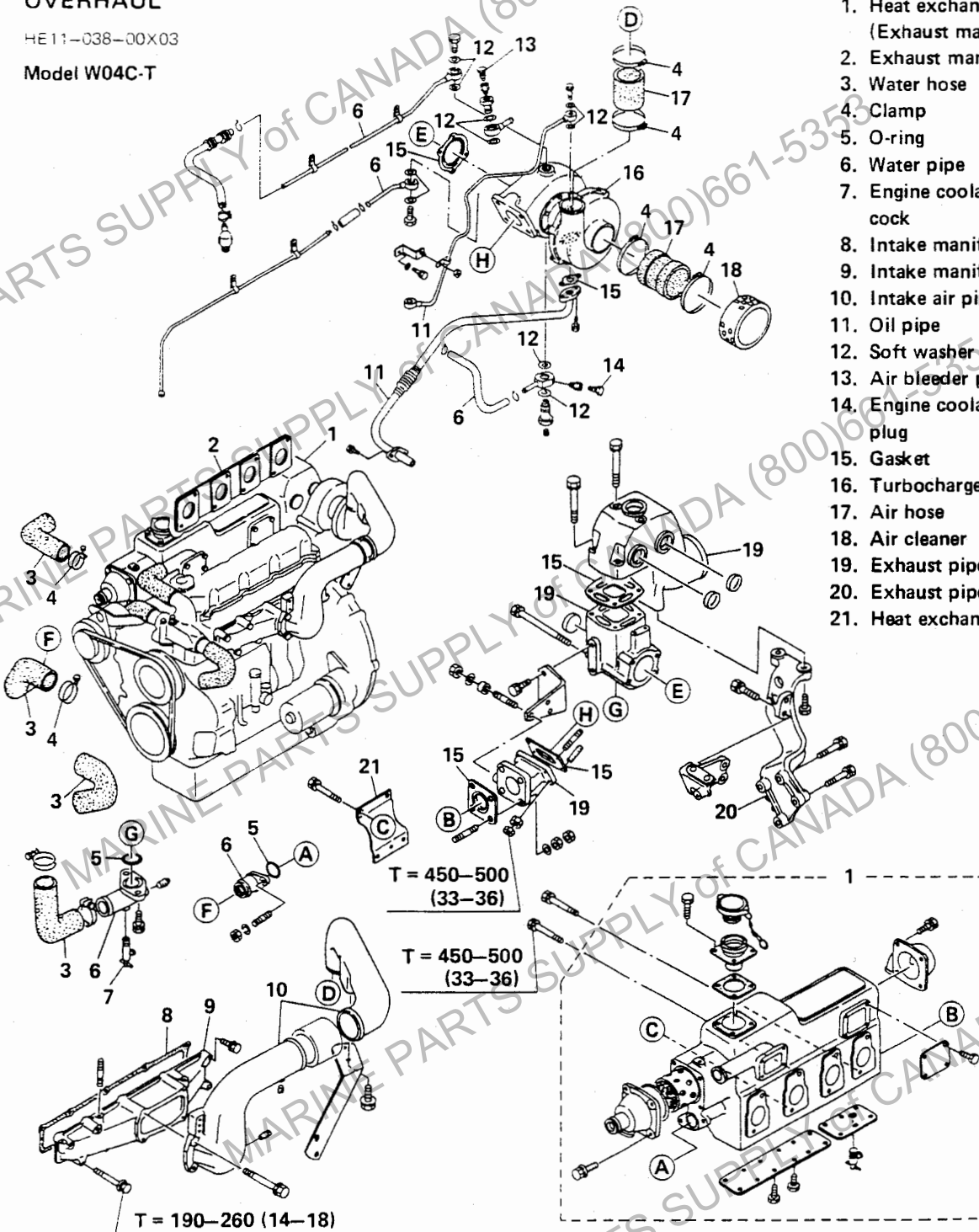

T = Tightening torque: kg-cm (lb.ft)

SM3-1838

OVERHAUL

HE11-039-00X05, 06

Model W04C-TI

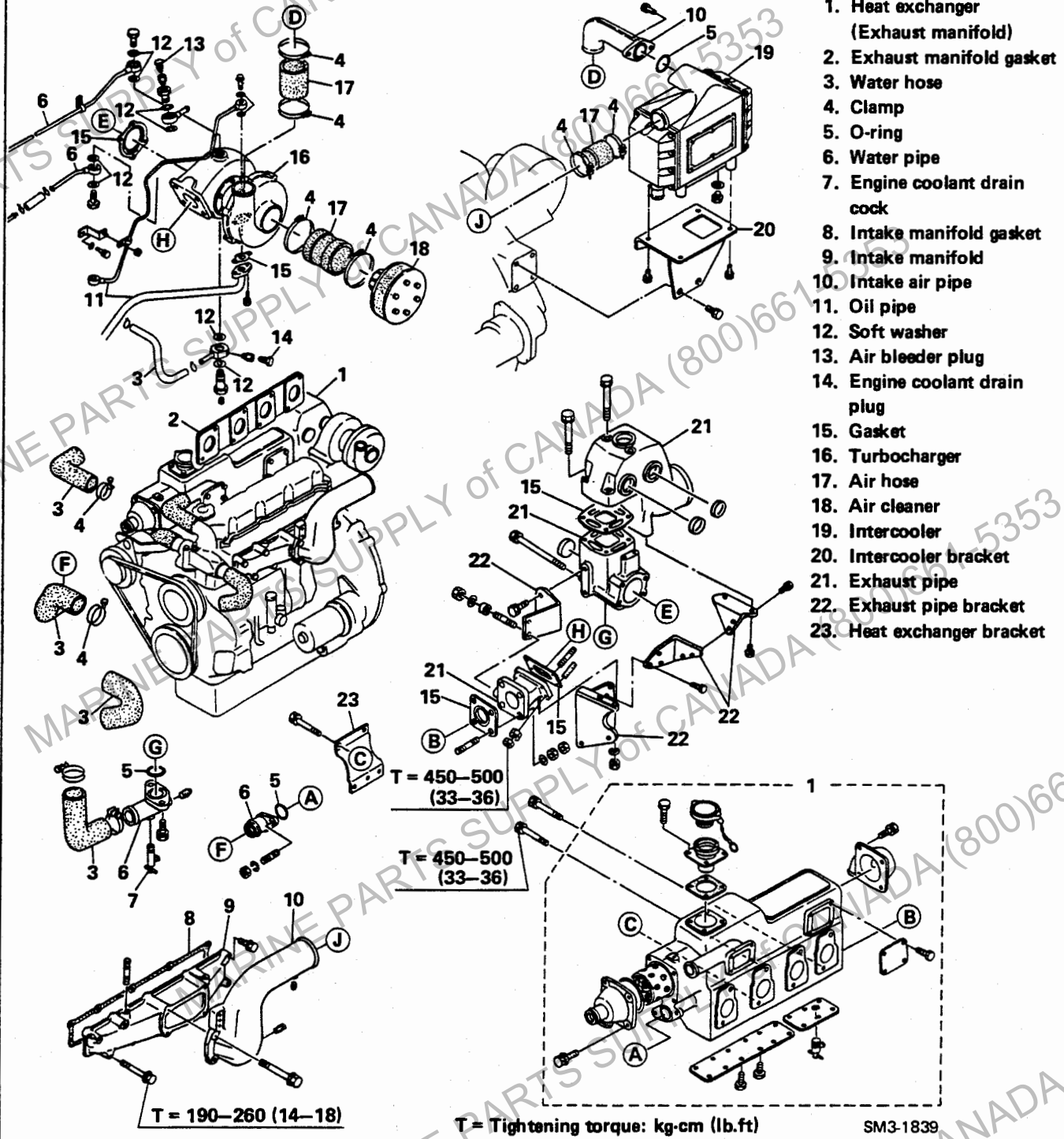

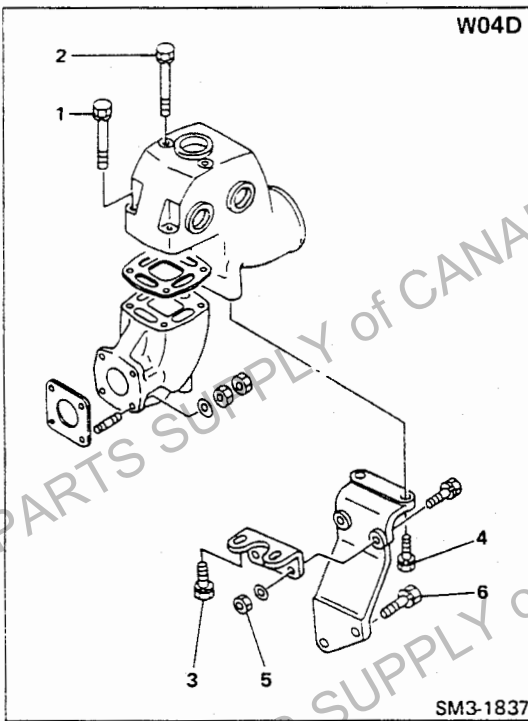
**IMPORTANT POINTS – MOUNTING****INSTALL THE EXHAUST PIPES.**

1. Install the connector and turbocharger on the heat exchanger (For W04C-T and W04C-TI).
2. Temporarily install the mounting brackets and exhaust pipes.
3. Tighten the bolts to the specified torque in the tightening order as shown.

Tightening Torque:**For W04D**

- 1 : 500–600 kg-cm (37–43 lb.ft)
- 2 : 500–600 kg-cm (37–43 lb.ft)
- 3 : 500–600 kg-cm (37–43 lb.ft)
- 4 : 450–500 kg-cm (33–36 lb.ft)
- 5 : 450–500 kg-cm (33–36 lb.ft)
- 6 : 1,000–1,300 kg-cm (73–94 lb.ft)

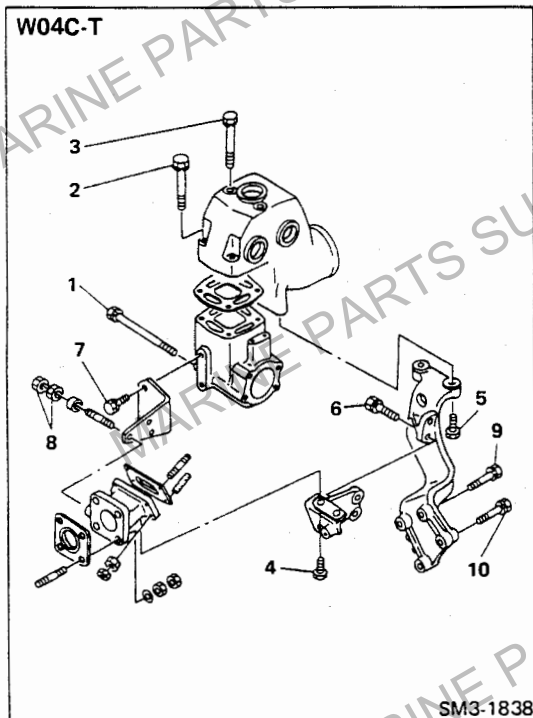
**For W04C-T**

- 1 : 190–270 kg-cm (14–19 lb.ft)
- 2 : 400–600 kg-cm (37–43 lb.ft)
- 3 : 500–600 kg-cm (37–43 lb.ft)
- 4 : 450–500 kg-cm (33–36 lb.ft)
- 5 : 350–400 kg-cm (26–28 lb.ft)
- 6 : 350–400 kg-cm (26–28 lb.ft)
- 7 : 350–400 kg-cm (26–28 lb.ft)
- 8 : 450–500 kg-cm (33–36 lb.ft)
- 9 : 1,000–1,300 kg-cm (73–94 lb.ft)
- 10 : 500–600 kg-cm (37–43 lb.ft)

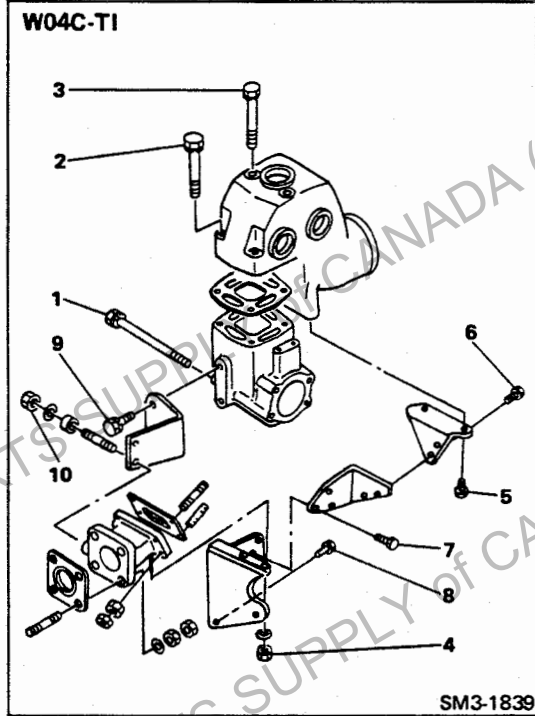

For W04C-TI

- 1 : 190–270 kg-cm (14–19 lb.ft)
- 2 : 500–600 kg-cm (37–43 lb.ft)
- 3 : 500–600 kg-cm (37–43 lb.ft)
- 4 : 450–500 kg-cm (33–36 lb.ft)
- 5 : 350–400 kg-cm (26–28 lb.ft)
- 6 : 350–400 kg-cm (26–28 lb.ft)
- 7 : 350–400 kg-cm (26–28 lb.ft)
- 8 : 1,000–1,300 kg-cm (73–94 lb.ft)
- 9 : 350–400 kg-cm (26–28 lb.ft)
- 10 : 450–500 kg-cm (33–36 lb.ft)

ENGINE TUNE-UP

NOTE: In case of marine engine equipped with seawater pump, never rotate the crankshaft in reverse direction (Clockwise viewed from flywheel). Reverse rotation may damage impeller in seawater pump.

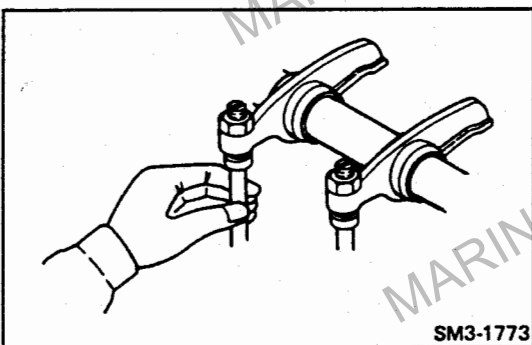
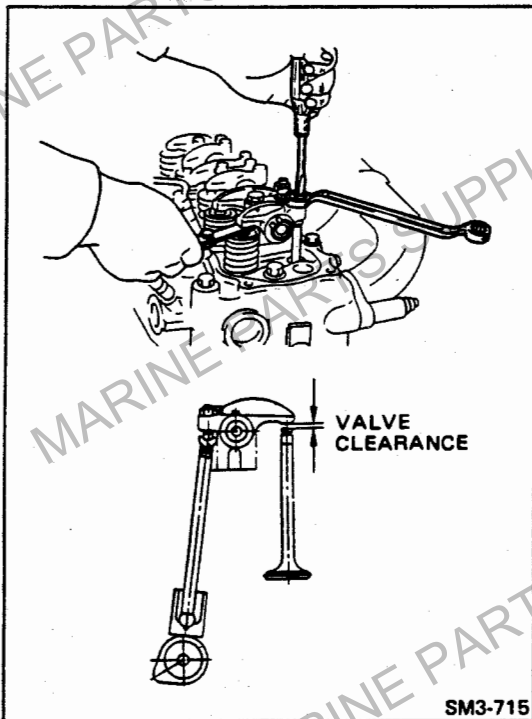
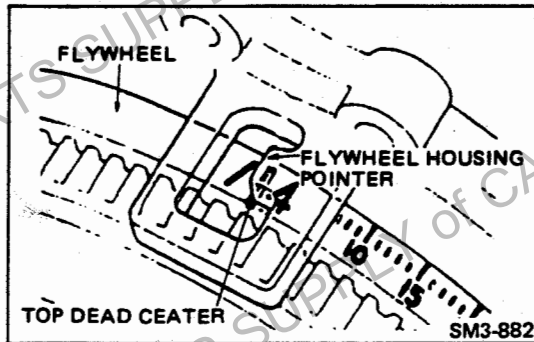

VALVE CLEARANCE

INSPECTION AND ADJUSTMENT TO THE VALVE CLEARANCE

1. Set the No. 1 piston to top dead center of compression stroke.

2. With the No. 1 piston positioned at top dead center and of the compression stroke, adjust the No. 1 valve clearance using a thickness gauge. The thickness gauge should move with a very slight pull.

Valve Clearance: Refer to SECTION DATA AND SPECIFICATIONS.

3. Adjust the other valves. Turn the crankshaft counter-clockwise 180° viewed from flywheel side. Adjust the valve clearance for each cylinder in the firing order.

Firing Order: 1-3-4-2

METHOD FOR DETERMINING IF THE NO. 1 OR NO. 4 PISTON IS AT THE TOP DEAD CENTER OF THE COMPRESSION STROKE.

Turning the crankshaft, align the mark "1-4" on the flywheel with the pointer on the flywheel housing. In this position either the No. 1 or No. 4 piston is at the top dead center of the compression stroke.

1. If both the No. 1 intake and exhaust rocker arms can be moved easily by hand, the No. 1 piston is at top dead center of the compression stroke.

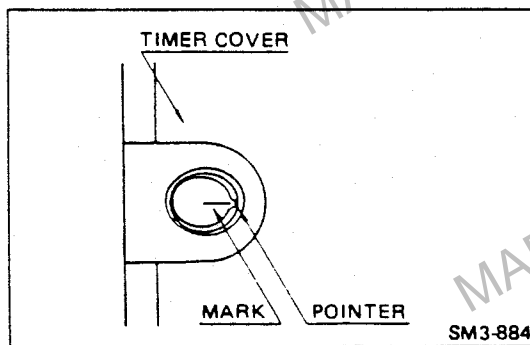
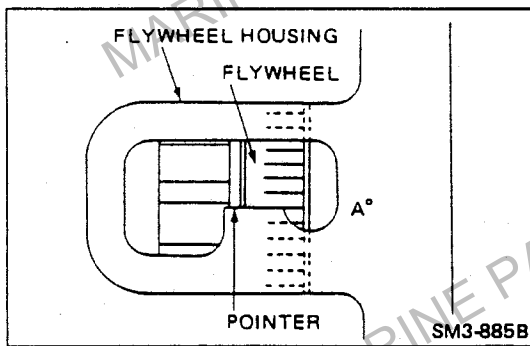
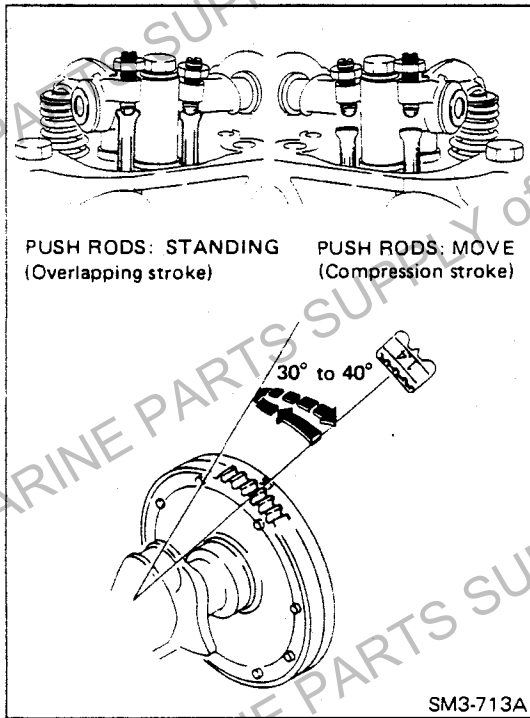
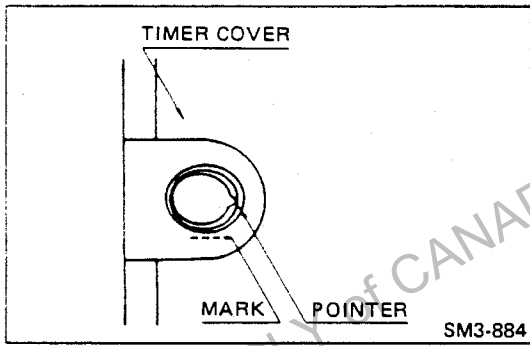

2. If the injection timing mark is nearly aligned with the pointer, the No. 1 piston is at top dead center on the compression stroke.

NOTE: If not, turn the crankshaft one complete revolution and align marks as above.

3. While locking the push rod of No. 1 and No. 4 pistons. Turn the flywheel counter-clockwise and clockwise about 30° to 40° (see left figure).

If the piston whose exhaust and intake push rods do not move during the interval, it is at the top dead center on the compression stroke.

If the piston whose push rods have moved, it is at the completion of the exhaust and begun of the intake stroke (overlapping stroke).

NOTE: Always loosen the lock nut and raise the adjusting screws fully to the top. If the adjusting screws are too low, the piston and valves may strike each other during valve clearance adjustment.

INJECTION TIMING

INSPECT THE INJECTION TIMING.

1. Rotate the crankshaft clockwise viewing from the timing gear cover side to align the injection timing marks on the flywheel at A° before top dead center of the compression stroke of the No. 1 cylinder, as seen in the injection hole of the flywheel housing.

Injection Timing (A): Refer to SECTION DATA AND SPECIFICATIONS.

BTDC: Before Top Dead Center

2. Check that the injection timing mark on the automatic timer is aligned with timer cover pointer. If not, adjust the injection timing.

NOTE: When adjusting the injection timing, refer to "INJECTION PUMP" in SECTION ENGINE COMPONENT PARTS for details.

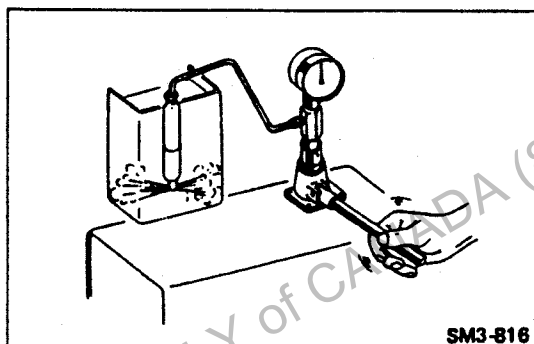

SM3-816

INJECTION NOZZLE**INSPECT AND ADJUST THE INJECTION PRESSURE.**

Refer to "INJECTION NOZZLE" in SECTION FUEL SYSTEM.

TEST THE SPRAY PROFILE.

Refer to "INJECTION NOZZLE" in SECTION FUEL SYSTEM.

TEST THE FUEL LEAKAGE.

Refer to "INJECTION NOZZLE" in SECTION FUEL SYSTEM.

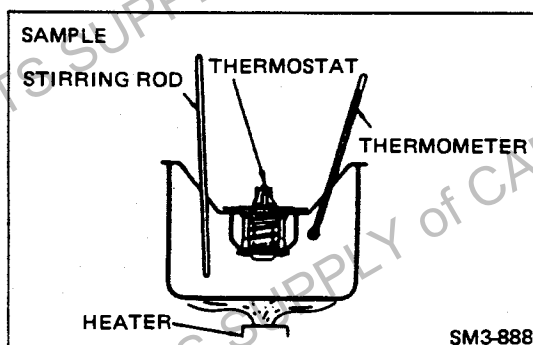

SM3-888

THERMOSTAT**INSPECT THE THERMOSTAT FUNCTION.**

1. Place the thermostat in hot water and check the opening temperature and the lift.
2. Using a thermometer, check to see the thermostat opens at the specified temperature: Refer to "THERMOSTAT" in SECTION COOLING SYSTEM.
3. Immerse the thermostat in hot water and measure the lift of the pellet after a period of 5 minutes using vernier calipers. Measure the position of the bottom of the pellet before and after heating the thermostat.

Valve Lift: Refer to "THERMOSTAT" in SECTION COOLING SYSTEM.

4. Immerse a heated thermostat in water of normal temperature. If it completely closes within 5 minutes it is satisfactory. If it remains even slightly open, it is defective and must be replaced.

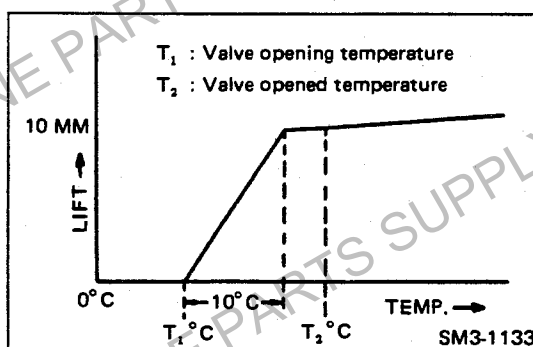

SM3-1133

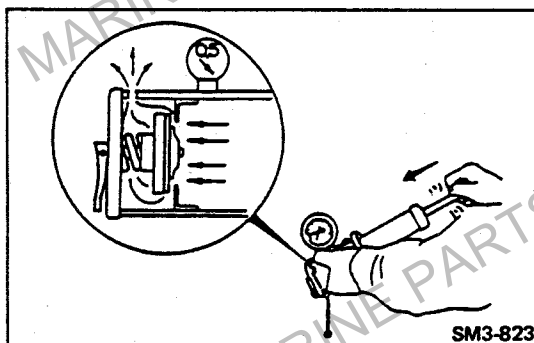

SM3-823

COOLANT FILLER CAP**INSPECT THE FILLER CAP FUNCTION.**

Check the filler cap pressure using a cap tester.

0.5 : 0.4–0.6 kg/cm² (5.7–8.5 lb/sq.in)

0.9 : 0.75–1.05 kg/cm² (10.7–14.9 lb/sq.in)

- NOTE:**
- The filler cap pressure is shown on the filler cap, and it should be confirmed.
 - If the cap pressure is incorrect, there is a risk of abnormally high pressure being generated in the cooling system, which may cause the hose to drop off or burst and, in turn, damage the engine.

WARNING

The cap should not be removed while the engine and cooling system are hot. This can result personal injury.

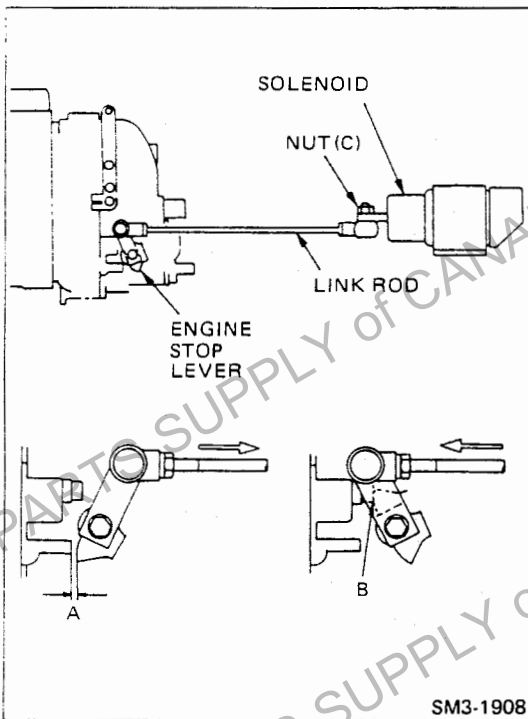

SM3-1908

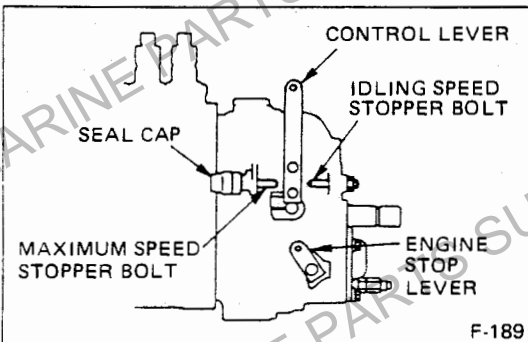

F-189

ENGINE CONTROL

ADJUST THE SOLENOID (ENGINE STOP) LINK ROD.

1. Adjust the link rod length so that the clearance between the stopper of the governor case and the engine stop lever becomes "A" when the solenoid plunger is fully pushed in.

Assembly Standard "A": 2–3 mm (0.08–0.11 in)

- NOTE:
- Install the link rod with the nut(c) at the top.
 - If the clearance adjustment is unsatisfactory or the action of the solenoid is sluggish, solenoid seizure, insufficient output or engine stoppage may result.

2. After the above adjustment is over, move the link rod by hand and make sure that it moves lightly.
3. When the engine is running, the clearance between the engine stop lever and the stopper becomes "B".

Assembly Standard "B": 0 mm (0 in)

ADJUST THE ENGINE IDLING SPEED.

When straight drive navigation is not smoothly made at the time of a sea trial in engine at idle, adjust it according to the following procedures.

1. Disconnect the throttle control cable from engine port (left) side and the starboard (right) side.
2. Loosen the idling speed stopper bolt lock nut.
3. Adjust through varying the engine speed using the idling speed stopper bolt on the injection pump so that straight drive navigation is made.

NOTE:

Increase in engine speed: Turn the idling speed stopper bolt blockwise.

Decrease in engine speed: Turn the idling speed stopper bolt counter-clockwise.

Engine Idling Speed: Refer to section DATA AND SPECIFICATIONS.

4. Upon completion of adjustment of engine idling speed, lock the stopper bolt with nut and apply paint on the stopper bolt and nut.

NOTE: When adjusting the all adjusting devices on the fuel injection pump governor, except the idling speed stopper bolt, refer to CHAPTER GV, INJECTION PUMP GOVERNOR.



RECOMMENDED LUBRICANTS FOR ALL HINO VEHICLES

HINO MOTORS, LTD.
OVERSEAS OPERATIONS
SERVICE DIV.
TOKYO, JAPAN

No.	LUBRICANTS	POSITIONS	ATMOSPHERIC TEMP.	S.A.E. NO.	BP	CALTEX	CASTROL	ESSO	GULF	MOBIL	SHELL	TOTAL
	ENGINE OIL (A.P.I. CD) Previous Classification (A.P.I. DS) (MIL-L-2104C) (MIL-L-45199B)		Above 32°C (90°F)	40	Vanellus C 3 40	RPM DELO 400 Oil SAE 40 or 15W/40 RPM DELO 300 Oil SAE 40	Castrol or Deusol CRD 40, Turbomax Castrol or Deusol RX Super 40, 15W/40	Essolube D-3 40, XD-3 40	Gulf Super Duty Motor Oil 40, 15W-40	Mobil Delvac 1340 Mobil Delvac Super 15W-40	Myrina Oil 40, 20W-40, 15W-40 Rimula X Oil 40 Rimula CT 40	TOTAL Rubia S 40 TOTAL Rubia TM 15W40
			32 ~ 0°C (90 ~ 32°F)	30	Vanellus C 3 30	RPM DELO 400 Oil SAE 30 or 15W/40 RPM DELO 300 Oil SAE 30	Castrol or Deusol CRD 30 Castrol or Deusol RX Super 30, 15W/40	Essolube D-3 30, XD-3 30	Gulf Super Duty Motor Oil 30, 15W-40	Mobil Delvac 1330 Mobil Delvac Super 15W-40	Myrina Oil 30, 20W-40, 15W-40 Rimula X Oil 30, 10W-30 Rimula CT30	TOTAL Rubia S 30 TOTAL Rubia TM 15W40
			0 ~ -12°C	20	Vanellus C 3 20	RPM DELO 400 Oil SAE 20/20W, 15W/40	Castrol or Deusol CRD 20W/20 Castrol or Deusol	Essolube D-3 20W	Gulf Super Duty	Mobil Delvac 1310 Mobil Delvac Super	Myrina Oil 20, 20W-40, 15W-40	TOTAL Rubia S 20 TOTAL
17	INJECTION PUMP TIMER GREASE (MIL-G-10924B)	Injection Pump Timer			Energrease L-2	Marlak Multipurpose 2 or Marlak All Purpose 2	Castrol LM Grease	Esso Multipurpose Grease	Gulflex Poly	Mobilgrease MP, 77, MS	Retinax A Alvania Grease R2	TOTAL Multis EP 1
18	AUTO GREASER GREASE (MIL-G-18709A 17740)	Centralized Lubricator			Energrease LS-EPI	Multifak EP 0	Castrol Impervia CT Light	Beacon EP1	Gulf Crown Grease E.P.No 0	Mobilplex 44	Alvania EP Grease R0 or Alvania R1	TOTAL Multis EP 1
19	BRAKE AND CLUTCH FLUID	Brake & Clutch			Brake Fluid	Heavy Duty Brake fluid	Castrol Disc Brake Fluid Castrol Brake Fluid Crimson Castrol Girling Universal Brake Fluid	Esso Brake Fluid HD	Cruise Master Super Heavy Duty Oot 3 Motor Vehicle Brake Fluid	Mobil Super Heavy Duty Brake Fluid	Donax B or HB Shell Super Heavy Duty Brake Fluid	TOTAL Brake Fluid (TOTAL HBf)
20	ANTI FREEZE (MIL-H-5559A)	Engine, Radiator & Window Washer			Anti Frost	AF Engine Coolant	Castrol Anti-Freeze Castrol Long Life Coolant	Esso Anti Freeze Coolant	Cruise Master Antifreeze And Summer Coolant	Mobil Permazone	Shellzone(U.S.A.) Glycoshell Plus (European Countries) Shellsafe Anti-Freeze P281 Coolguard	TOTAL ANTIGEL

No.	LUBRICANTS	POSITIONS	DOW CORNING (U.S.A.)	GENERAL ELECTRIC (U.S.A.)	WACKER CHEMIE (WEST GERMANY)
21	SILICONE GREASE	Spring Brake Chamber	MOLYKOTE(R) 33 Grease Medium	Silicone Grease G-341M G-322L G-330M	Silicone Grease 300 Medium
22	SILICONE GREASE (MIL-L-15719A)	Valve (Brake, Relay, Spring Brake Control, Spring Brake Release Control and LSV)	MOLYKOTE(R) 44 Grease Medium	Silicone Grease G-351M	Silicone Grease 400 Medium
23	SILICONE OIL	Air Suspension Leventing Valve	Dow Corning 200 Fluid 1000 CS	Silicone Fluid SF-96-1000	Silicone Fluid AK 1000

Note: Lubricants were amended according to new classification by A.P.I. (American Petroleum Institute)

ENGINE TUNE-UP ON TEST BENCH

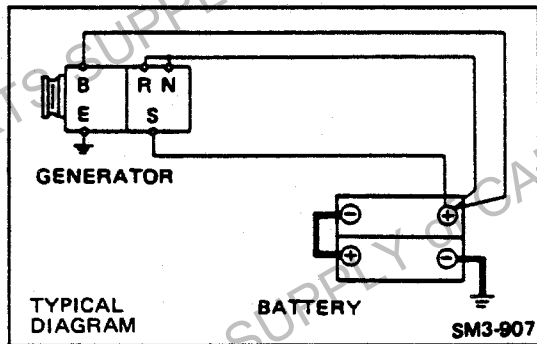

- NOTE:** In case of marine engine equipped with seawater pump
- Never rotate the crankshaft in reverse direction (Clockwise viewed from flywheel). Reverse rotation may damage impeller in seawater pump.
 - Do not run engine without water in the seawater cooling system. The seawater pump damage can result. Starting the engine when the generator is not connected to the battery may damage the generator. Always connect to the battery.

SET THE ENGINE ASSEMBLY ON A TEST BENCH.

1. Add the proper amount of the specified engine oil through the oil filler cap on the cylinder head cover.
2. Add coolant.

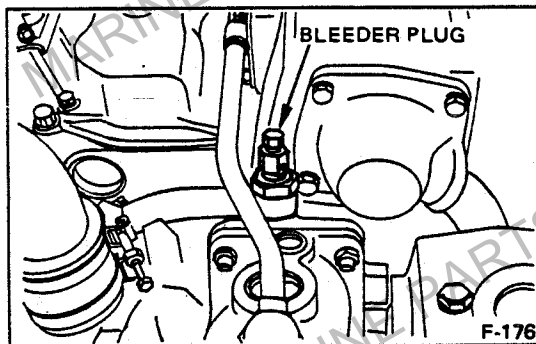
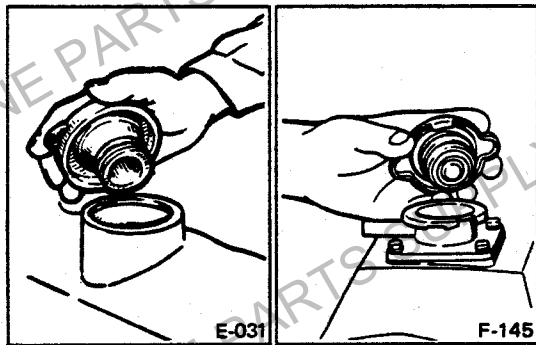

- NOTE:** In case of engine equipped with water-cooled turbocharger, bleed air from bleeder plug.

BLEED AIR FROM FUEL SYSTEM.

Refer to SECTION FUEL SYSTEM.

CHECK THE INJECTION TIMING.

Refer to "INJECTION PUMP" in SECTION ENGINE COMPONENT PARTS.

CHECK THE VALVE CLEARANCE.

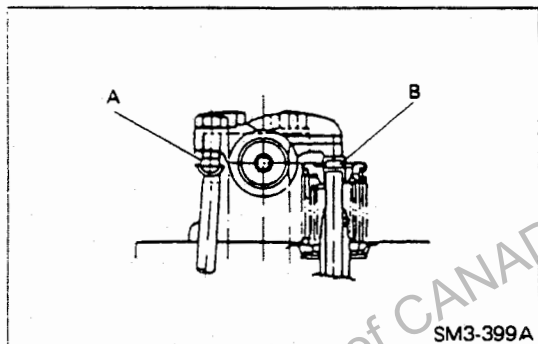

SM3-399A

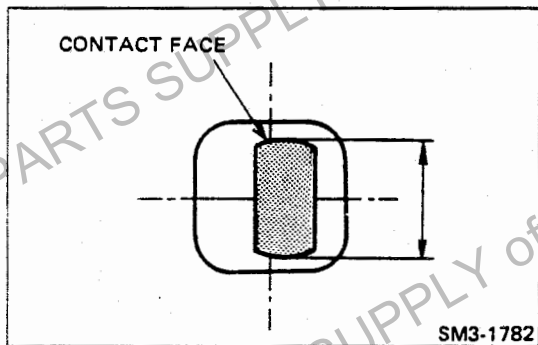

SM3-1782

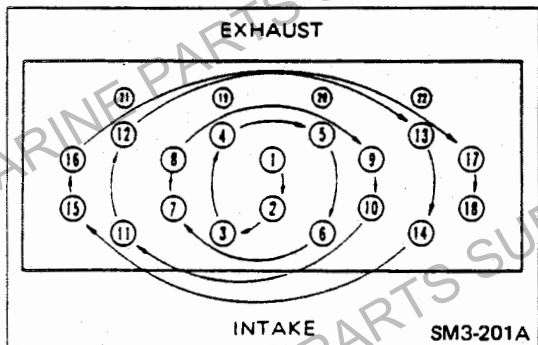

SM3-201A

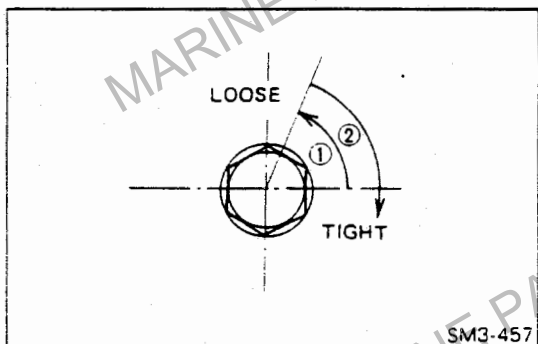

SM3-457

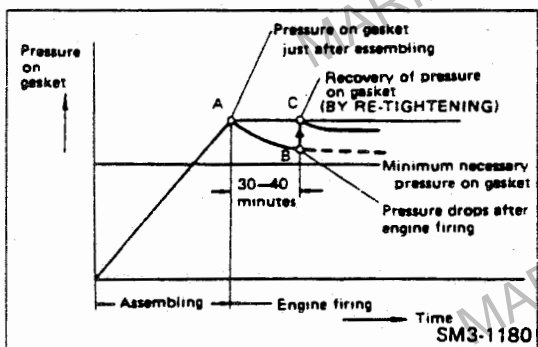

SM3-1180

START THE ENGINE.

NOTE: Before starting the engine, make sure that the fuel cut lever of the fuel injection pump is operating normally.

1. Check the oil feed to rocker arms.
 - a. Set the engine speed: Refer to SECTION DATA AND SPECIFICATION.
 - b. Within one minute after starting the engine, oil should flow to the head (Face A) of all push rods and the head (Face B) of all valves. If the time required for the oil to flow to the rocker arms is long, various troubles such as seizing, abnormal wear and unusual noise may occur.

2. Check the contact of the rocker arm and valve stem caps. After running the engine, a contact of approx. 8 mm (0.315 in) should be obtained at the cap contact face of the rocker arm.

If the contact face is one sided, the valve will tilt, resulting in valve seizure, breakage, damage, or wear of the rocker arm stem cap.

3. Retighten the cylinder head bolts. After tightening cylinder head bolt to specified torque, run the engine for about 30 to 40 minutes at a water temperature of about 80°C. Then loosen cylinder each head bolt 1/8-1/4 turn and retighten, in sequence, to specified torque.

Special Tool: Socket wrench (09411-1260)

- NOTE:**
- In case of marine engine equipped with heat exchanger (exhaust manifold), loosen the heat exchanger bracket fitting bolts before retightening the cylinder head bolts.
 - Be sure to loosen one bolt at a time, then retighten it before going on to the next bolt.
 - By retightening, face pressure of cylinder head is restored from point B to C as shown.
 - Retighten at the first 30 hours following servicing which involves the loosening or removal of any cylinder head bolt. Such servicing includes replacement of the cylinder head gasket, servicing of the valve gear parts, and the like.

RECHECK THE VALVE CLEARANCE, WHEN ENGINE IS COLD.

PROCEDURE FOR INSTALLING JOINTS AND GASKETS OF ENGINE PIPES

1. Gasket seal type (aluminum + rubber, asbestos or copper).

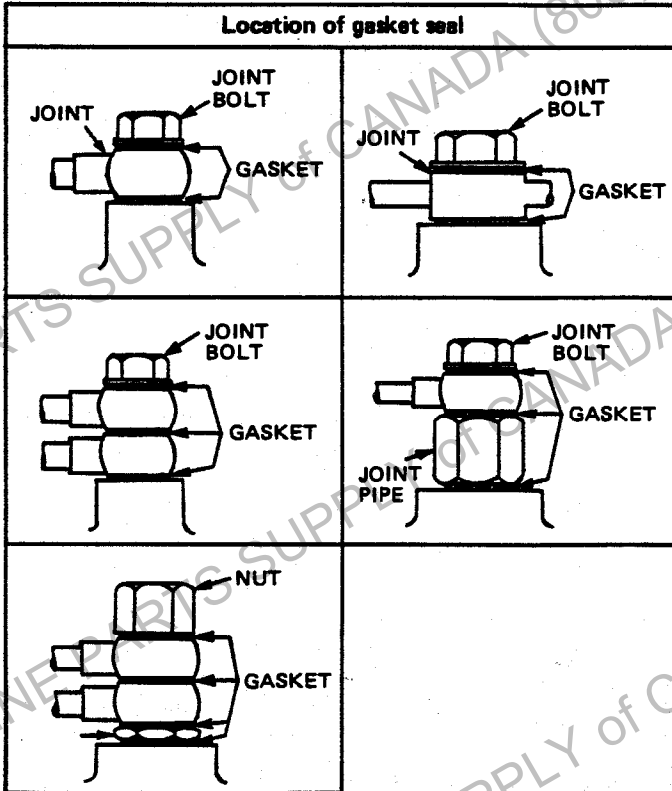

Tightening torque chart

Clamping screw size (Diameter) mm (in)	Tightening torque kg-cm (lb.ft)
8 (0.315)	120-170 (9-12)
10 (0.394)	180-230 (13-16)
12 (0.472)	230-280 (17-20)
14 (0.551)	230-280 (17-20)
16 (0.630)	300-350 (22-25)
18 (0.709)	400-450 (29-32)
20 (0.787)	400-450 (29-32)
22 (0.866)	530-600 (38-43)
24 (0.945)	720-800 (52-57)
28 (1.102)	1,300-1,500 (94-108)

2. Metal seal type (Flares connector type).

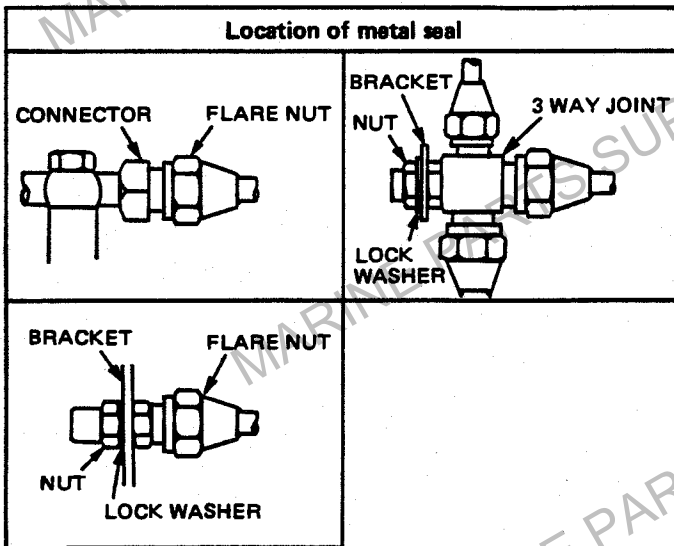

Tightening torque chart

Clamping screw size (Diameter) mm (in)	Tightening torque kg-cm (lb.ft)
12 (0.472)	200-220 (15-16)
14 (0.551)	330-360 (24-26)
16 (0.630)	400-500 (29-36)
18 (0.709)	600-700 (43-51)
20 (0.787)	650-700 (47-51)

3. Metal seal type (Nipples connectors type)

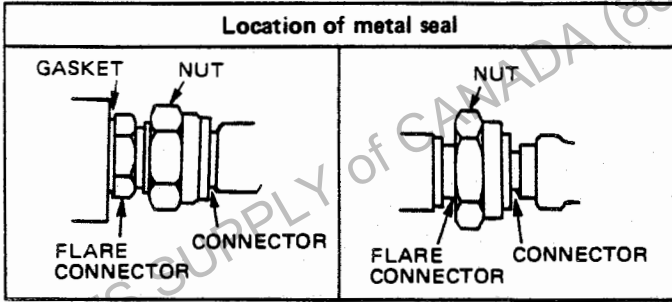

Tightening torque chart

Clamping screw size (Diameter) mm (in)	Tightening torque kg-cm (lb.ft)
10 (0.394)	100-150 (7-10)
20 (0.787)	200-250 (14-18)

- NOTE:
- Before installing the joints, ensure that there is no dirt or burrs adhering to the various seat faces (pipe joints, gaskets, etc.)
 - Because the pipes can move relatively free during installation and the seat faces are liable to tilt, first temporarily tighten the pipes, then tighten them to specification and ensure that there is no leakage from them.
 - When tightening two pipes together, be very careful that they do not rotate together.
 - After installing the pipes, apply the correct pressure to each pipe joint and ensure that there is no leakage.
 - Ensure that the various tightening torques conform to the above table.
 - If a soft washer #4840 FR-N (aluminum + rubber and carbon press fit part) is loosened or removed subsequent to being installed, be sure and replace it with a new one.
There is no need to replace it, however, for normal retightening.

CHAPTER EE

ELECTRICAL EQUIPMENT

DATA AND SPECIFICATIONS	EE- 2
LOCATION OF ELECTRICAL EQUIPMENT	EE- 2
TROUBLESHOOTING	EE- 3
GENERAL INSTRUCTION	EE- 5
BATTERY	EE- 6
ENGINE STARTING CIRCUIT	EE- 7
PRE-HEAT CIRCUIT	EE- 8
ENGINE STOP AND WARNING LAMP CIRCUIT	EE- 8
METER AND GAUGE CIRCUIT	EE-10
ELECTRICAL WIRING DIAGRAM	

DATA AND SPECIFICATIONS

Electrical system

Voltage	Direct current 12 volts or 24 volts
Ground	Negative (-) ground
Warning and indicator lamp	2W
Meter and gauge illumination lamp	1.7W

LOCATION OF ELECTRICAL EQUIPMENT

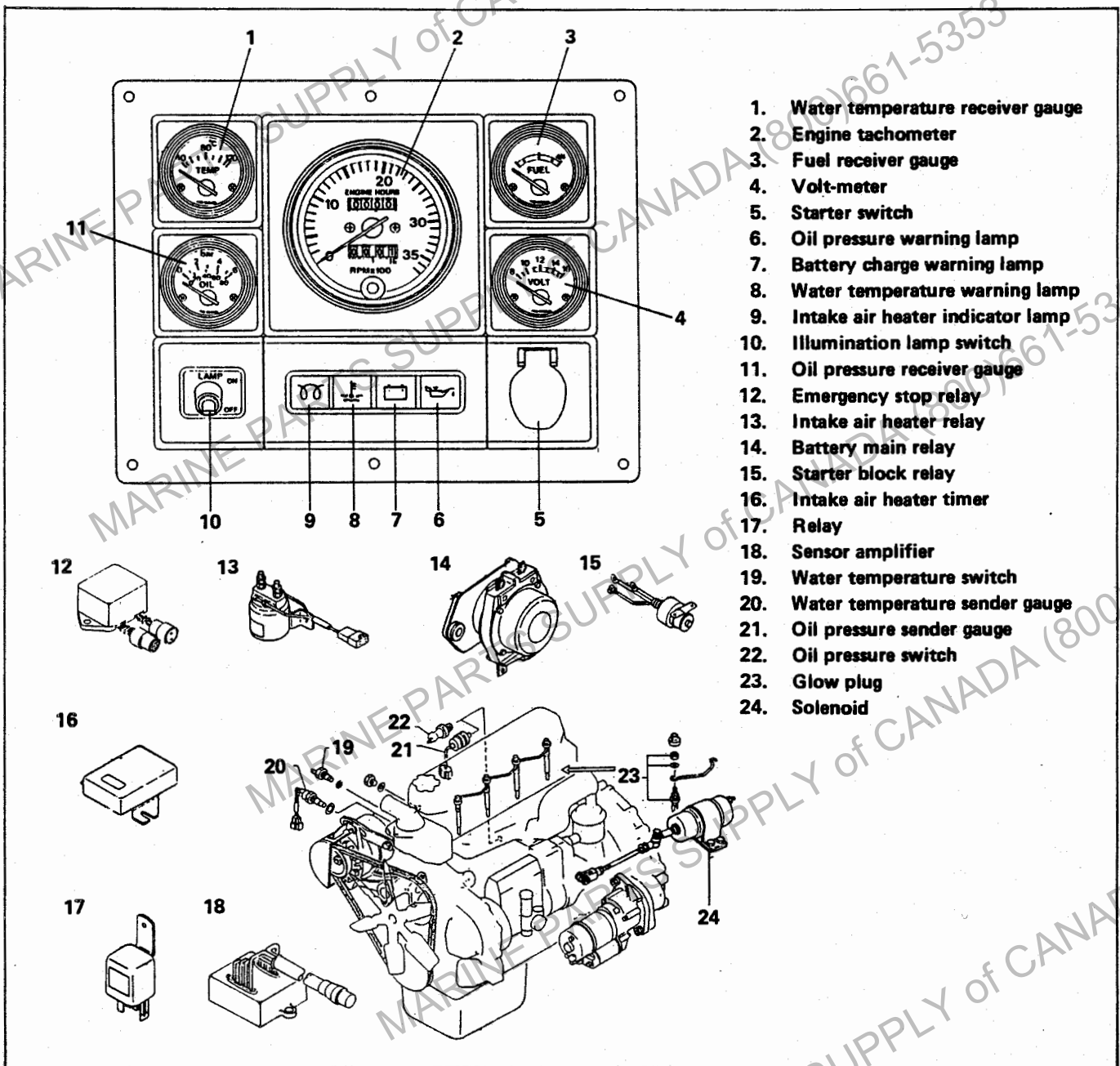

1. Water temperature receiver gauge
2. Engine tachometer
3. Fuel receiver gauge
4. Volt-meter
5. Starter switch
6. Oil pressure warning lamp
7. Battery charge warning lamp
8. Water temperature warning lamp
9. Intake air heater indicator lamp
10. Illumination lamp switch
11. Oil pressure receiver gauge
12. Emergency stop relay
13. Intake air heater relay
14. Battery main relay
15. Starter block relay
16. Intake air heater timer
17. Relay
18. Sensor amplifier
19. Water temperature switch
20. Water temperature sender gauge
21. Oil pressure sender gauge
22. Oil pressure switch
23. Glow plug
24. Solenoid

TROUBLESHOOTING

Symptom	Possible cause	Remedy/Prevention
A lot of exhaust is emitted but the engine does not start or is difficult to start. (Auxiliary starting device: Standard specifications) (Auxiliary starting device: Option specifications)	Auxiliary starting device	
	<ul style="list-style-type: none"> Loose wiring of heater signal or defective heater signal. Defective heater plug Defective wiring between heater and plug Defective power relay Defective heater plug Defective wiring between heater and plug Defective sensing resistor Defective heater control timer 	Repair or replace. Replace. Repair. Repair or replace. Replace. Repair. Replace. Replace.
Solenoid does not operate when engine is running, even if abnormal signal is input. (Engine does not stop.)	Emergency stop relay	
	<ul style="list-style-type: none"> Alternator malfunctions Insufficient battery voltage Faulty connection at N terminal of emergency relay Defective solenoid 	Repair or replace. Charge or replace. Repair. Replace.
Solenoid operates when starter switch is turned ON	Emergency stop relay	
	<ul style="list-style-type: none"> Faulty connection at R1 terminal Faulty connection at B and C terminals 	Repair. Repair.
When the starter switch is turned OFF, the battery relay switch goes OFF and the solenoid fails to operate.	Battery	
	<ul style="list-style-type: none"> Insufficient voltage 	Charge or replace.
	Alternator	
	<ul style="list-style-type: none"> Malfunctions 	Repair or replace.
Starter chattering or improper plunging	Battery	
	<ul style="list-style-type: none"> Insufficient voltage 	Charge or replace.
	Starter block relay	
	<ul style="list-style-type: none"> Faulty connection at terminals Internal circuit abnormal Relay switch abnormality (faulty contacts), improper sliding between rod and moving core, or open-circuit or burnt out coil 	Repair. Replace. Replace.
	Starter switch	
	<ul style="list-style-type: none"> Faulty connection at terminals 	



<u>Symptom</u>	<u>Possible cause</u>	<u>Remedy/Prevention</u>
Improper disengagement of starter or defective hold function when engine is rotating	Alternator	
	• Defective (correct voltage not generated)	Repair or replace.
	Starter block relay	
	• Improper terminal connection	Repair.
	• Reverse connections to terminals B and C	Repair.
Re-plunging during inertial rotation	Starter block relay	
	• Reverse connections to terminals B and C	Repair.

MARINE PARTS SUPPLY of CANADA (800)661-5353



GENERAL INSTRUCTION

WARNING

Be sure to disconnect the ground cable before servicing the electrical circuits.

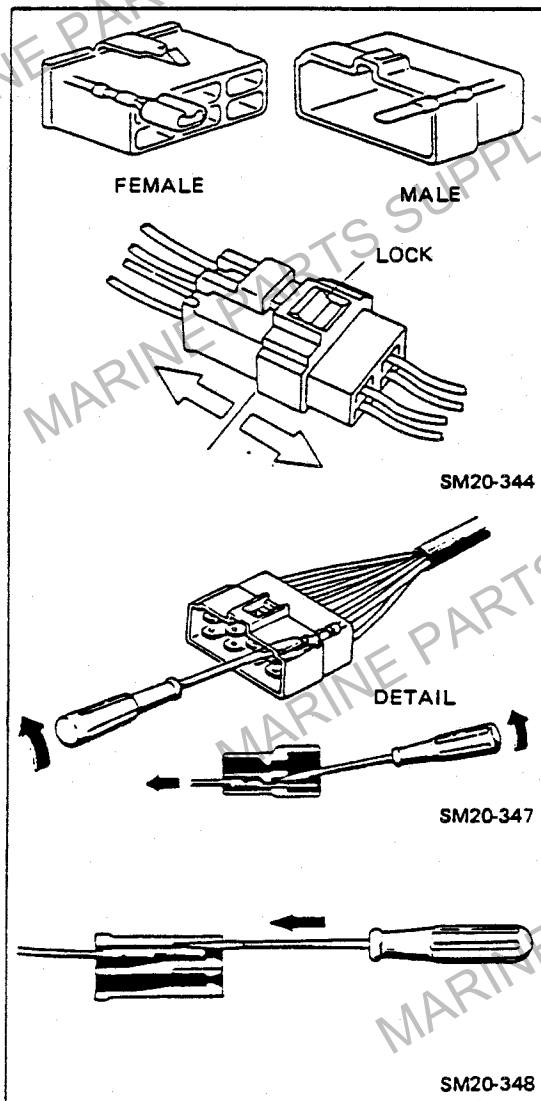
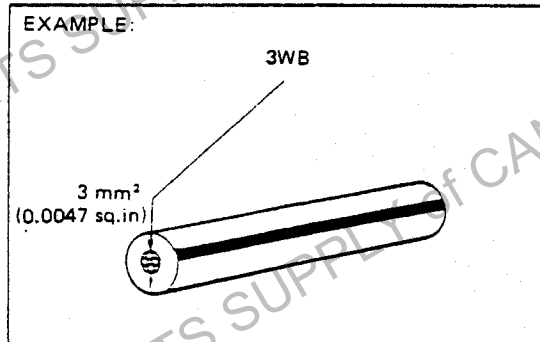

WIRING CODE

- Wiring colors are indicated by a code.

B : Black	Lg : Light green
Br : Brown	R : Red
G : Green	W : White
L : Blue	Y : Yellow
- The first letter indicates the ground wire color and second letter indicates the stripe color.
- Arabic numerals indicates the cross sectional area of wire.

3 : 3 mm²

CONNECTOR

- The connectors exist as male and female connectors.
- Male and female connectors are classified according to the shape of the terminals in the connector (refer to the figure on the left).
- Male and female connectors are provided with a lock, so that they can not be separated easily.
- For connector separation, hold the connector, unlock the lock and separate the connector.

NOTE: When the connector is pulled by pulling the wires, the connection between the terminals and the wires will be damaged.

- Remove the terminal from the connector.
 - Insert a miniature screwdriver or a terminal puller between terminal and connector and unlock the lock between terminal and connector.
 - When the lock has been released, pull the wire to remove the terminal.
- Install the terminal in the connector.
 - Insert the terminal into the connector until the clicking sound of lock engagement can be heard.
 - Pull the wire to confirm correct lock engagement.

FUSE

- The power supply must be switched off for fuse replacement.
- Use a fuse with a suitable amperage.

NOTE: Wire burning may be caused when a fuse with an excessively large current capacity is used.

- If the fuse should blow frequently, investigate the cause and remove it.

BATTERY

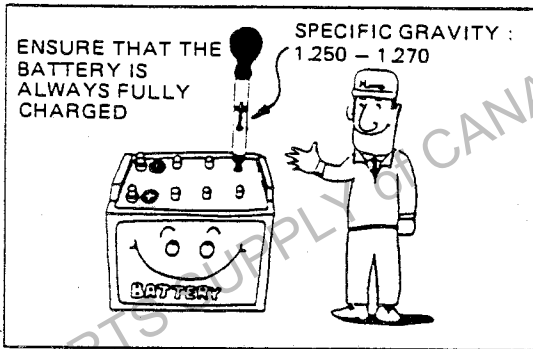

CONVERSION FORMULA FOR SPECIFIC GRAVITY.

- The specific gravity of electrolyte changes according to the temperature of the electrolyte itself, hence it is based on a temperature of 20°C (68°F). Consequently, if the temperature is not 20°C when the specific gravity is measured, it is necessary to convert the measured value to the equivalent value at 20°C.

Temperature conversion formula: $S_{20} = S_t + 0.0007 (t - 20)$

Where,

- S_{20} is the specific gravity at 20°C (reference temperature)
- S_t is the specific gravity at the measuring temperature
- t is the temperature during measurement
- 0.0007 is the temperature coefficient of the electrolyte

NOTE: As a rough guide, if the temperature of the electrolyte rises or falls by 15°C (59°F), the specific gravity of the electrolyte will vary by about 0.01.

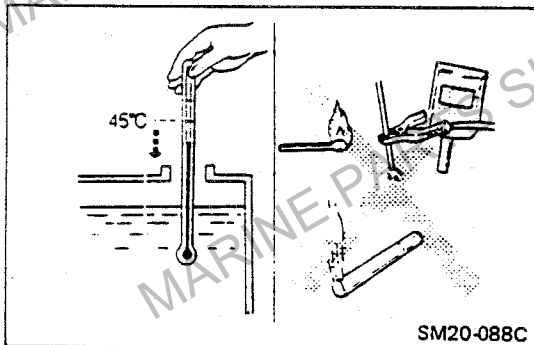

BATTERY CHARGING

- Be careful of the following points.
 - 1) While the battery is being charged, ensure that the temperature of the electrolyte does not rise above 45°C (113°F).
 - 2) While the battery is being charged, be particularly careful to keep it away from sources of fire.
 - 3) The amount of electrolyte must be within the specified level.

Specific gravity when battery is fully charged: 1.250 - 1.270 at 20°C (68°F)

CLEANING THE BATTERY

- If the terminals at the top of the battery are dirty, clean them with cold water or lukewarm water.
- Apply a light coating of grease to the terminals to prevent them from rusting so as to prevent faulty contact.

CONNECTING THE BATTERY CABLES

- Clamp the cables securely to prevent improper contact between the cables and the battery terminals.
- Be very careful not to connect the (+) and (-) leads in reverse. (because this may cause equipment run off the battery to be damaged.)

ENGINE STARTING CIRCUIT

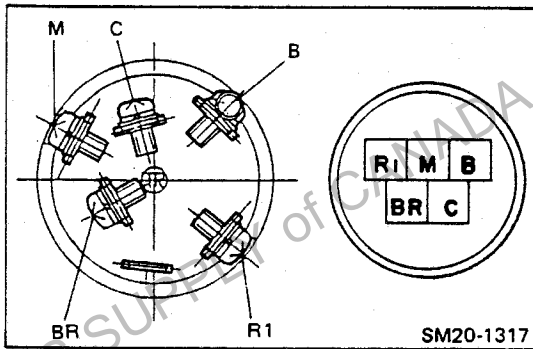

CHECK THE CONTINUITY OF THE STARTER SWITCH.

Check the continuity between terminals.

If continuity is not correct, replace the starter switch.

Terminal	B	R ₁	R ₂	M	BR	C
Switch position						
PRE-HEAT	○	○		○	○	
OFF	○	○				
ON	○			○	○	
START	○		○	○	○	○

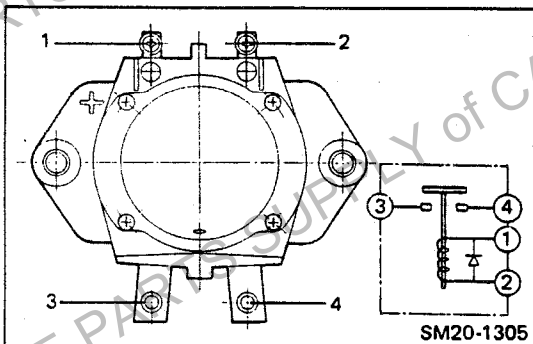

CHECK THE OPERATION OF BATTERY RELAY.

1. Check that there is continuity between terminals 1 and 2.
2. Check that there is no continuity between terminals 3 and 4.
3. Connect the positive (+) lead from the battery to terminal 1. Connect the negative (-) lead to terminal 2. Check that there is continuity between terminals 3 and 4.
4. If operation is not correct, replace the battery relay.

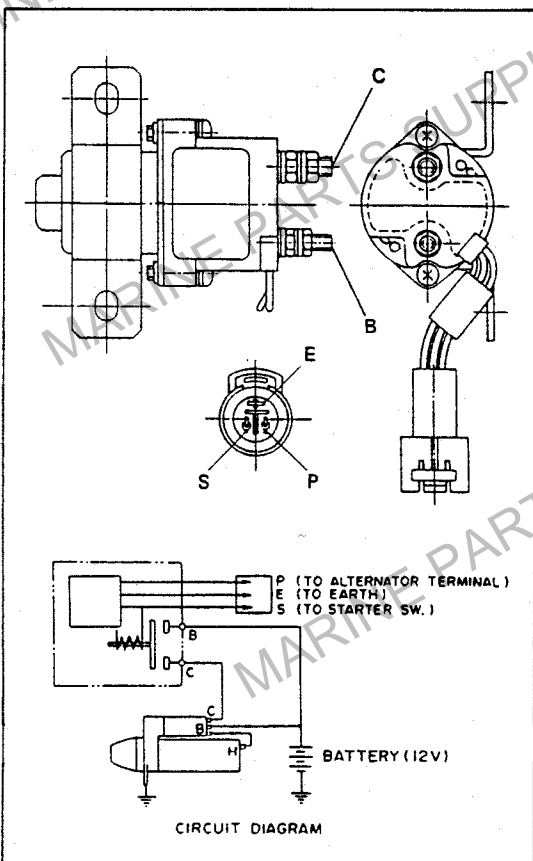

CHECK THE OPERATION OF THE STARTER BLOCK RELAY.

1. Check that there is no continuity between terminals C and B.
2. Connect the positive (+) lead from the battery to terminal S. Connect the negative (-) lead to terminal E. Check that there is continuity between terminals C and B.
3. Connect the positive (+) lead from the battery to terminal P. Connect the negative (-) lead to terminal E. Check that there is no continuity between terminals C and B.
4. If operation is not correct, replace the relay.

PRE-HEAT CIRCUIT

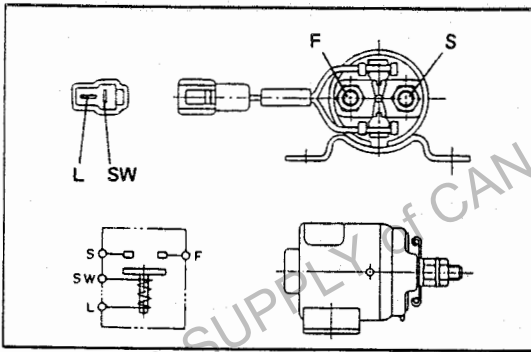

CHECK THE OPERATION OF THE INTAKE AIR HEATER RELAY.

1. Check that there is continuity between terminals SW and L.
2. Check that there is no continuity between terminals S and F.
3. Connect the positive (+) lead from the battery to terminal SW. Connect the negative (-) lead to terminal L. Check that there is continuity between terminals S and F.
4. If operation is not correct, replace the relay.

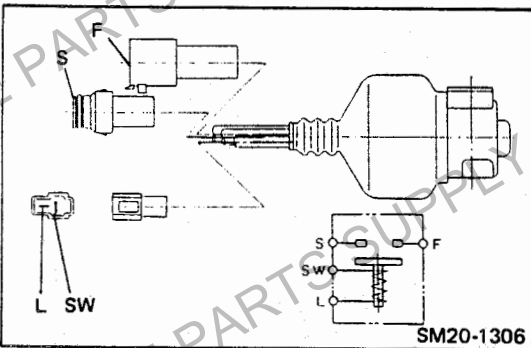

CHECK THE CONTINUITY OF THE HEATER PLUG.

Check the continuity between terminal and body ground.
If there is no continuity, replace the glow plug.

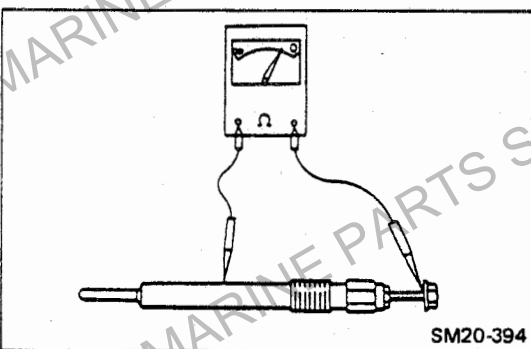

ENGINE STOP AND WARNING LAMP CIRCUIT

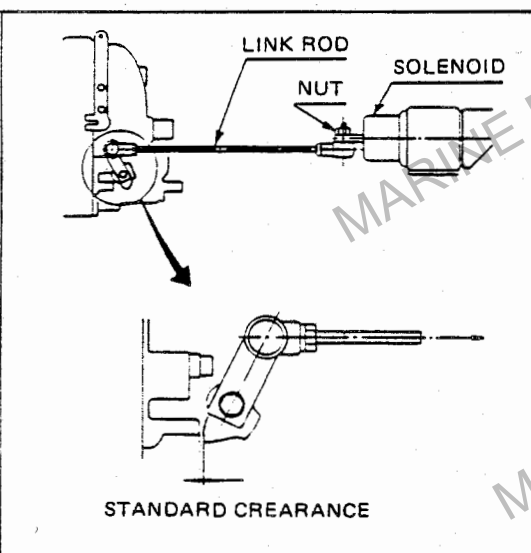

CHECK THE OPERATION OF THE SOLENOID AND ADJUST THE LINK ROD.

1. Connect the battery to the solenoid terminals and confirm that the solenoid is drawn in.
2. Push in the plunger by hand and confirm that there is a clearance between the stopper and the link rod.

Standard clearance: 2 – 3 mm (0.01188 – 0.1181 in)

If there is no clearance, perform adjustment with the link rod.

- NOTE:**
- If the clearance adjustment is unsatisfactory or the action of the solenoid is sluggish, solenoid seizure, insufficient output or engine stoppage may result.
 - Install the link rod with the nut at the top.

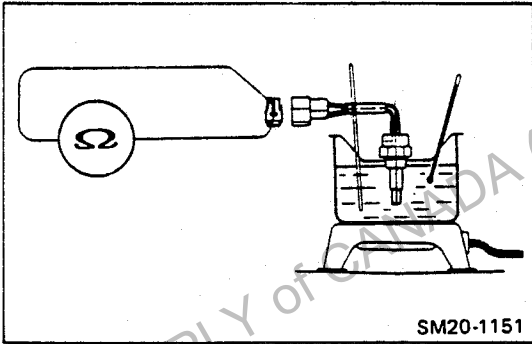

SM20-1151

CHECK THE CONTINUITY OF THE WATER TEMPERATURE SWITCH.

Check the continuity between terminals.
If continuity is not correct, replace the temperature switch.

Terminal	1	2
Water temperature: °C (°F)		
More than 96–100 (205–212)	○	○
Less than 91 (196)		

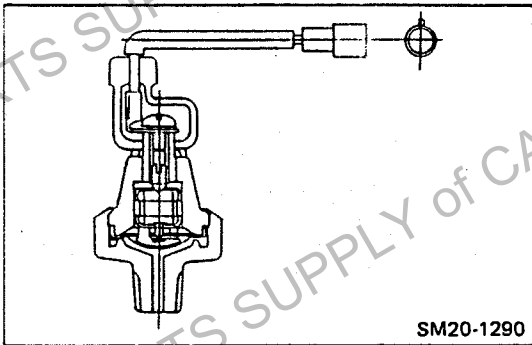

SM20-1290

CHECK THE OPERATION OF THE PRESSURE SWITCH.

1. Check the continuity between terminal and body ground.
 - a. Check that there is continuity when engine is stopped.
 - b. Check that there is no continuity when engine is running.
2. If continuity is not correct, replace the oil pressure switch.

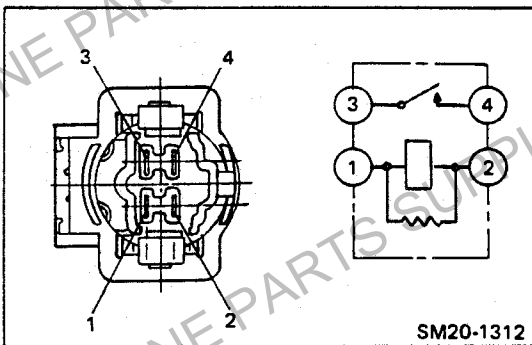

SM20-1312

CHECK THE OPERATION OF THE RELAY. (WATER TEMPERATURE WARNING LAMP RELAY)

1. Check that there is continuity between terminals 1 and 2.
2. Check that there is no continuity between terminals 3 and 4.
3. Connect the positive (+) lead from the battery to terminal 1. Connect the negative (-) lead to terminal 2. Check that there is continuity between terminals 3 and 4.
4. If operation is not correct, replace the relay.

METER AND GAUGE CIRCUIT

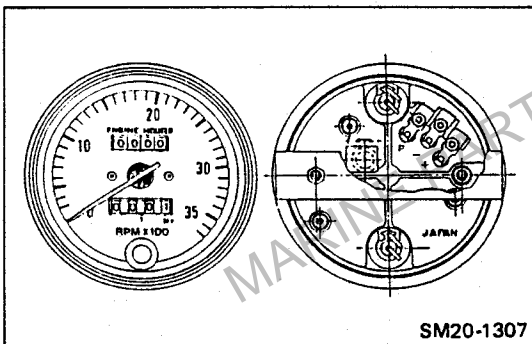

SM20-1307

CHECK THE OPERATION OF THE TACHOMETER.

1. Connect a turn-up test tachometer, and start the engine.
2. Check the tester and tachometer indications.
If the indicated value of tachometer is not correct, replace the tachometer.

Standard revolution (rpm)	600	1,800	3,000
Allowable value (rpm)	± 100	± 100	± 100

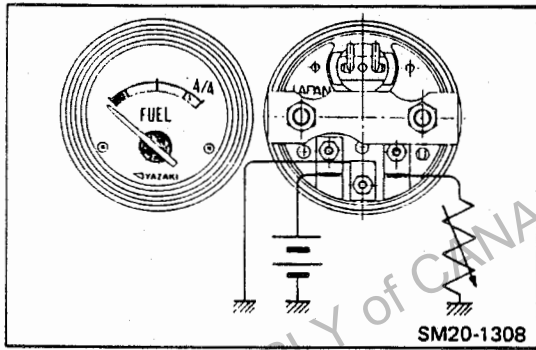

CHECK THE OPERATION OF THE FUEL RECEIVER GAUGE.

1. Wire the receiver gauge, variable resistor and battery, as shown in the figure at left. Check the indicated value on the receiver gauge at the reference resistance value.
2. If the indicated value is not correct, replace the receiver gauge.

Resistance: Ω	33.5	103	240
Gauge reading	F	1/2	E
Allowable value: %	+6 0	± 4	0 -5

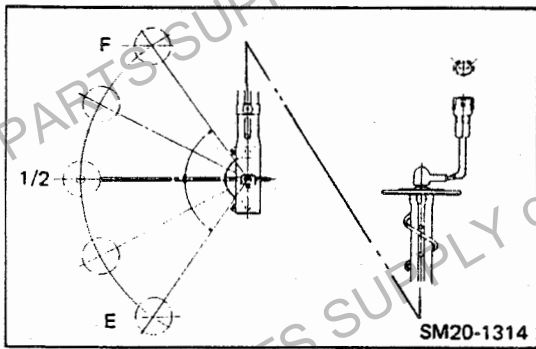

CHECK THE OPERATION OF THE FUEL SENDER GAUGE.

Measure the resistance between terminals.
If resistance is not correct, replace the sender gauge.

Float position	F	1/2	E
Standard resistance: Ω	30.1	103	250
Allowable value: Ω	± 3.4	± 10.3	± 24

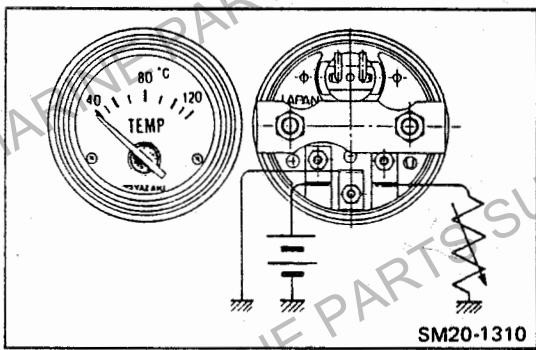

CHECK THE OPERATION OF THE WATER TEMPERATURE RECEIVER GAUGE.

1. Wire the receiver gauge, variable resistor and battery, as shown in the figure at left. Check the indicated value on the receiver gauge at the reference resistance value.
2. If the indicated value is not correct, replace the receiver gauge.

Resistance: Ω	43.2	23.7
Gauge reading: $^{\circ}\text{C}$ ($^{\circ}\text{F}$)	80 (176)	100 (212)
Allowable value: $^{\circ}\text{C}$ ($^{\circ}\text{F}$)	± 3.5	± 5.5

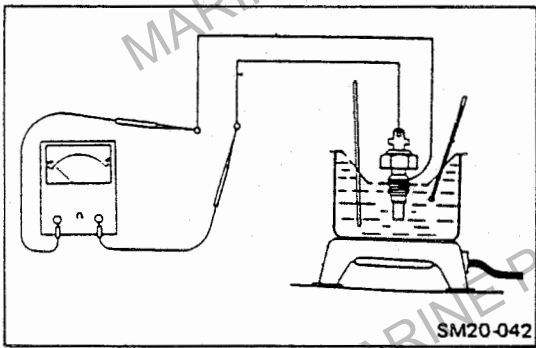

CHECK THE OPERATION OF THE WATER TEMPERATURE SENDER GAUGE.

1. Wire the sender gauge and ohmmeter as shown in the figure at left. Check the resistance value of the sender gauge at the standard water temperature.
2. If resistance value is not correct, replace the sender gauge.

Water temperature: $^{\circ}\text{C}$ ($^{\circ}\text{F}$)	50 (122)	80 (176)	100 (212)
Standard resistance: Ω	130	48.5	26.7
Allowable value: Ω	-	± 4.2	± 2.5

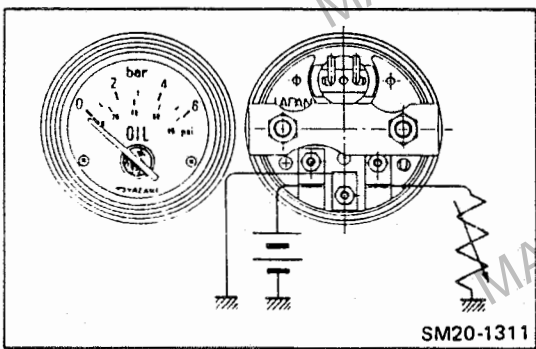

CHECK THE OPERATION OF THE OIL PRESSURE RECEIVER GAUGE.

1. Wire the receiver gauge, variable resistor and battery as shown in the figure at left. Check the indicated value on the receiver gauge at the reference current value.
2. If the indicated value is not correct, replace the receiver gauge.

Resistance: Ω	19	81	112
Gauge reading: bar (psi)	0	4 (56)	6 (84)
Allowable value: bar (psi)	± 0.3 (4.1)	+ 0.7 (9.7) - 0.6 (8.4)	-

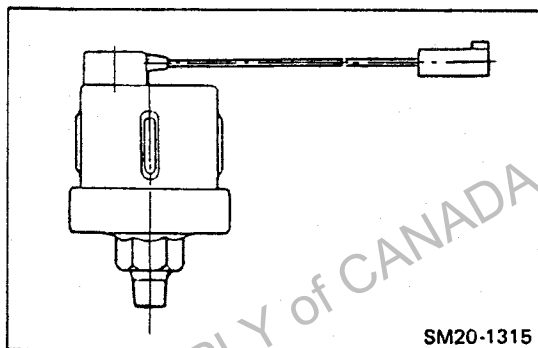

CHECK THE OPERATION OF THE OIL PRESSURE SENDER GAUGE.

1. Wire the sender gauge and ohmmeter as shown in the figure at left. Check the resistance between the sender gauge and the body ground.
2. If the measured value is not correct, replace the sender gauge.

Oil pressure kg/cm ² (lb/sq.in)	0	2 (28)	6 (85)
Standard resistance: Ω	19	49	110
Allowable value: Ω	± 2	± 5	± 9

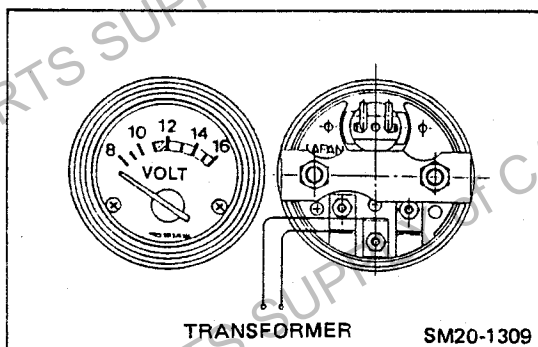

CHECK THE OPERATION OF THE VOLTMETER.

1. Wire the voltmeter and transformer as shown in the figure at left. Check the indicated value on the voltmeter at the reference voltage value.
2. If the indicated value is not correct, replace the voltmeter.

Gauge reading: V	12	14
Allowable value: V	± 0.5	± 0.5

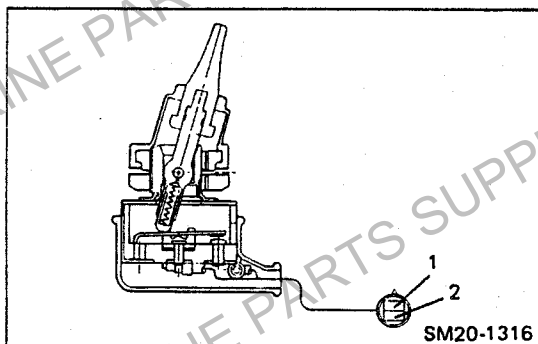

CHECK THE OPERATION OF THE GENERALLY USE SWITCH (ILLUMINATION LAMP SWITCH).

Check the continuity between terminals.
If operation is not correct, replace the switch.

Terminal	1	2
Switch position		
ON	○	○
OFF		

ELECTRICAL WIRING DIAGRAM : MODELS W04D, W04C-T AND W04C-TI

MAIN DECK

	B	R1	R2	M	BR	C
PH	○	○	○	○	○	○
OFF	○	○	○	○	○	○
ON	○	○	○	○	○	○
START	○	○	○	○	○	○

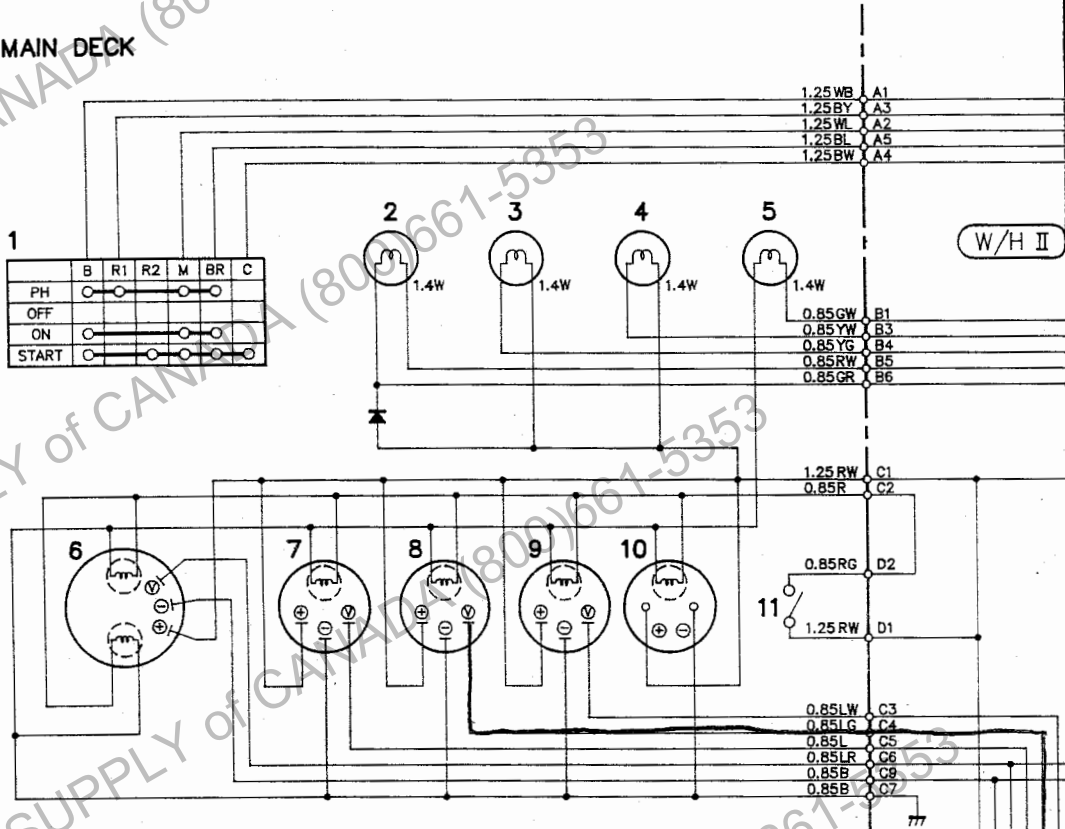

FLYING DECK

	B	R1	R2	M	BR	C
PH	○	○	○	○	○	○
OFF	○	○	○	○	○	○
ON	○	○	○	○	○	○
START	○	○	○	○	○	○

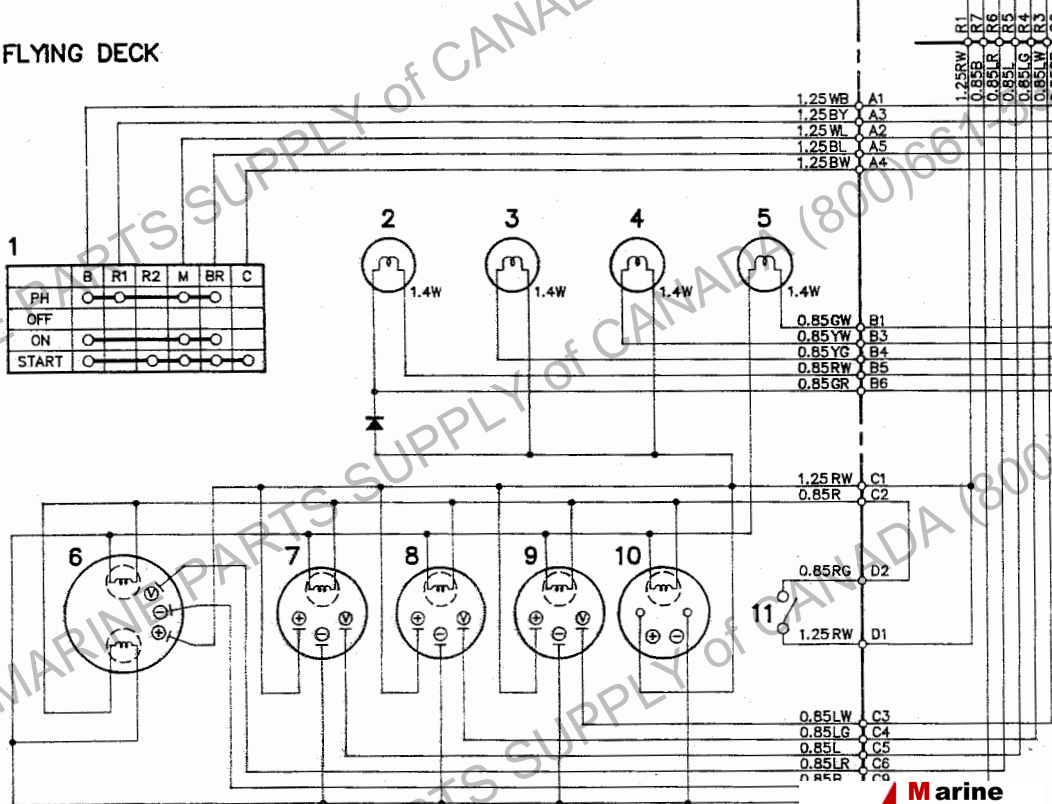

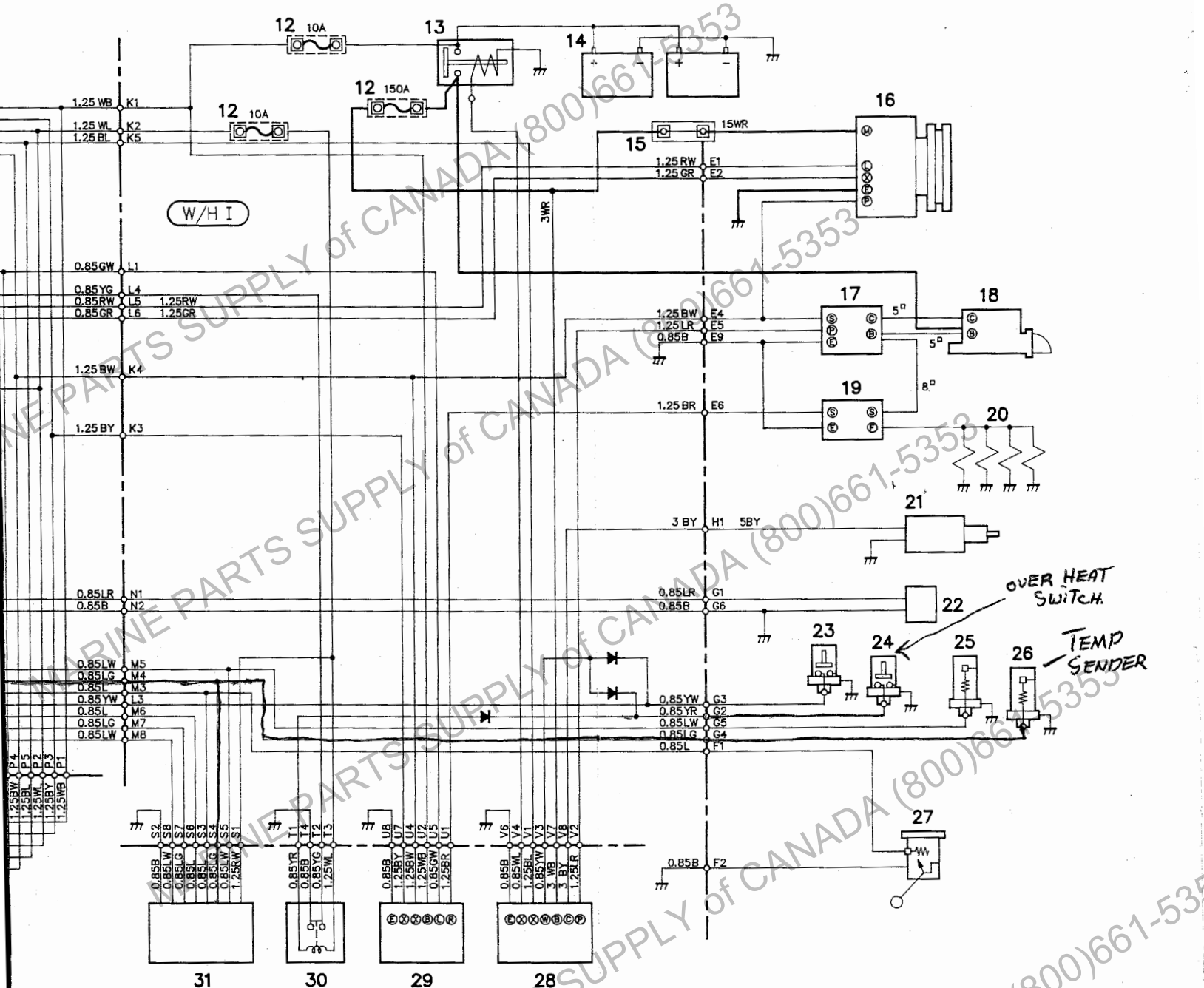

- | | | |
|---|-------------------------------|------------------------------------|
| 1. Starter switch | 12. Fuse | 23. Oil pressure switch |
| 2. Battery change warning lamp | 13. Battery main relay | 24. Water temperature switch |
| 3. Water temperature warning lamp | 14. Battery | 25. Oil pressure sender gauge |
| 4. Oil pressure warning lamp | 15. Junction block | 26. Water temperature sender gauge |
| 5. Intake air heater indicator lamp | 16. Alternator with regulator | 27. Fuel sender gauge |
| 6. Tachometer | 17. Starter block relay | 28. Emergency stop relay |
| 7. Fuel receiver gauge | 18. Starter | 29. Intake air heater timer |
| 8. Water temperature receiver gauge | 19. Intake air heater relay | 30. Relay |
| 9. Oil pressure receiver gauge | 20. Glow plug | 31. Sensor amplifier |
| 10. Volt-meter | 21. Solenoid | |
| 11. Instrument illumination lamp switch | 22. Revolution sensor | |

EWD-404-1/2

ELECTRICAL WIRING DIAGRAM : MODELS W04D, W04C-T AND W04C-TI (Con'd)

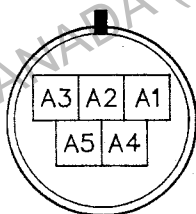

**STARTER SWITCH
COMBINATION METER SIDE**

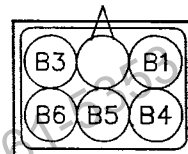

**INDICATOR AND WARNING
LAMP
COMBINATION METER SIDE**

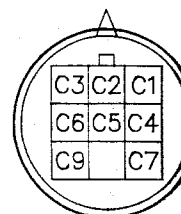

**METER AND GAUGE
COMBINATION**

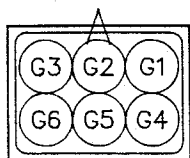

**REVOLUTION SENSOR
WATER TEMPERATURE WARNING
LAMP
OIL PRESSURE GAUGE
OIL PRESSURE WARNING LAMP
SENDER SIDE**



**SOLENOID
ENGINE SIDE**

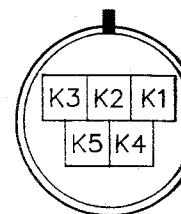

W/H II SIDE

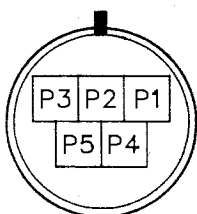

W/H

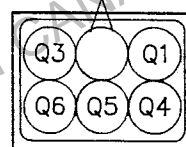

W/H III SIDE

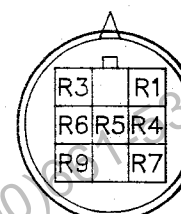

W/H III SIDE

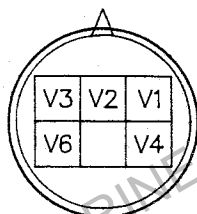

**EMERGENCY STOP
RELAY SIDE**



**EMERGENCY STOP
RELAY SIDE**



AND GAUGE
TION METER SIDE



INSTRUMENT ILLUMINATION
LAMP
COMBINATION METER SIDE

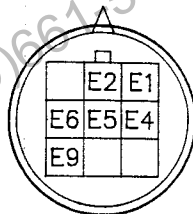

ALTERNATOR
STARTER BLOCK RELAY
INTAKE AIR HEATER RELAY
ENGINE SIDE

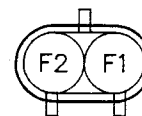

FUEL GAUGE
SENDER SIDE

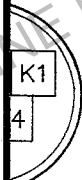

SIDE

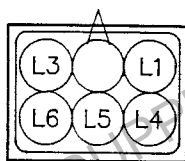

W/H II SIDE

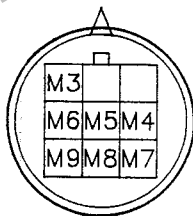

W/H II SIDE

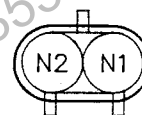

W/H SID II SIDE

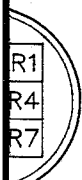

SIDE

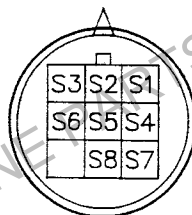

SENSOR AMPLIFIER SIDE

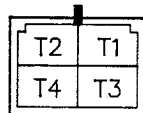

WATER TEMPERATURE
WARNING LAMP
RELAY SIDE

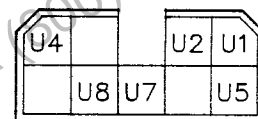

INTAKE AIR HEATER
TIMER RELAY SIDE

EWD-404-2/2

CHAPTER TU

TURBOCHARGER

DATA AND SPECIFICATIONS TU-2

DESCRIPTION TU-2

TROUBLESHOOTING TU-3

OVERHAUL CRITERIA TU-4

SPECIAL TOOL TU-5

TURBOCHARGER TU-6



DATA AND SPECIFICATIONS

Type	RHC 7
Turbine type	Radial flow type
Blower type	Centrifugal type
Lubricating method	External lubrication type
Bearing type	Full floating type
Direction of rotating	Counterclockwise as seen from the turbine side
temperature	

DESCRIPTION

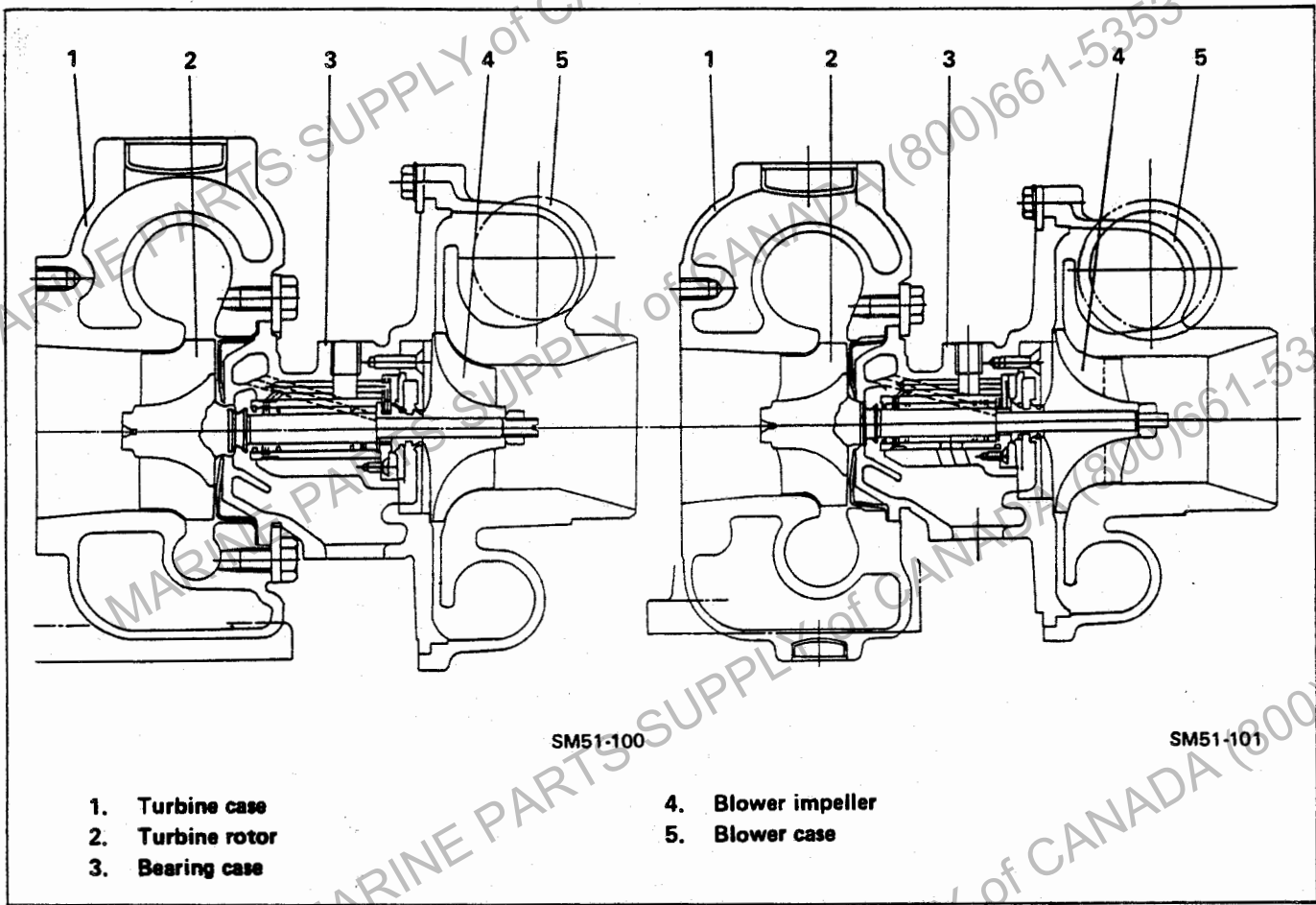

- 1. Turbine case
- 2. Turbine rotor
- 3. Bearing case

- 4. Blower impeller
- 5. Blower case

TROUBLESHOOTING

Symptom

Possible cause

Remedy/Prevention

Dense black smoke

Insufficient air intake

- Air cleaner is choked with dust, Disassemble and clean or replace causing greater intake air resistance. the air cleaner element.
- Air inlet is choked Repair.
- Air is leaking from intake manifold Repair.

Turbocharger does not rotate smoothly.

- Engine oil impurities deposited on Overhaul and clean turbocharger rotor, resulting in heavy rotation and/or change engine oil. or sticking.

Bearing sticking

- Insufficient lubrication or blockage Check lubricating oil system, of lubricating oil lines. and/or repair.
- Abnormal wear or damage of seal Repair. ring caused by wear of journal bearing, due to insufficient lubrication.
- Temperature of lubricating oil too high Check cooling system.
- Unbalanced rotating parts Change rotating parts.
- Incomplete warming-up, failure Operate vehicle properly, to idle before stopping engine, or jack rabbit starts.

Loose or damaged turbine rotor or blower impeller.

- Over-rotation Check and adjust the engine.
- Temperature of exhaust gas too high Check and adjust the engine.
- Foreign matter present Remove foreign material. Inspect the air cleaner and air intake manifold. Repair if necessary.
- Worn thrust bearing Overhaul and repair.
- Incomplete assembly Reassembly.

High volume exhaust like noise.

- Exhaust gas leaking before turbocharger, Check and repair connections. therefore insufficient revolution.
- Deformed or blocked exhaust gas lines Repair. therefore insufficient revolution.

White smoke

- Choking defects, or deformation of Repair and replace the lines. oil return lines so that oil leaks around blower or turbine sides.
- Seal ring may be broken or worn due Replace the thrust washer. to abnormal wear of thrust washer.

<u>Symptom</u>	<u>Possible cause</u>	<u>Remedy/Prevention</u>
Loss of power	Gas leakage from exhaust system	Repair.
	Air leakage from air manifold	Repair.
	Clogged air cleaner element	Clean or replace.
	Turbocharger dirty or damaged	Repair or replace.
Poor response of turbocharger	Carbon accumulation on the turbine side seal ring and heavy rotation.	Change engine oil, clean turbocharger.
	Poor combustion	Check fuel system and improve combustion.
High pitched noise and vibration	Noise	
	• So called "surging"	Overhaul and clean turbocharger.
	Surging sometimes occurs when the gas passage at the nozzle of the turbine housing is choked or when compressed air does not flow in proper responses to acceleration.	
	• Loosen rotating parts	Replace.
	Vibration	
• Joints loose between turbocharger and intake, exhaust manifold or oil lines.	Check the mounting and repair.	
• Damaged bearing, loose rotating parts, imbalanced rotating parts, etc.	Repair.	

OVERHAUL CRITERIA

CONDITIONS WHICH DETERMINE WHEN A TURBOCHARGER OVERHAUL MAY BE NEEDED.

THE ENGINE LACKS POWER OR ENGINE EXHAUST EMITS BLACK SMOKE.

BOOST PRESSURE IS BELOW THE NORMAL VALUE.

Inspect the turbocharger boost pressure according to the following procedures.

NOTE: Before measurement

- Coolant temperature should approximately 80°C.
- Air cleaner element should be clean.

WARNING

When making a pressure test, be sure that personnel are adequately protected against any stream of pressurized air that might be released by a leak or the rupture of a hose.

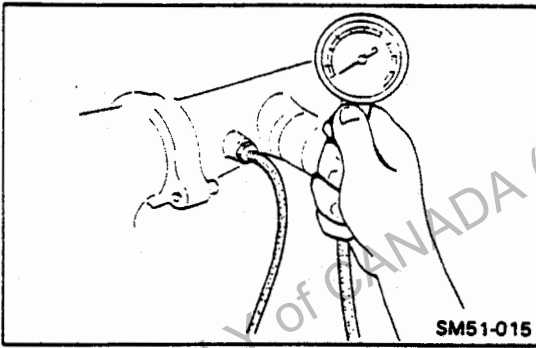

1. Remove the blind plug on the intake pipe and install the hose and pressure gauge (special tools).

Special Tools: Pressure Gauge (09444-1250)
Hose (17108-1040)

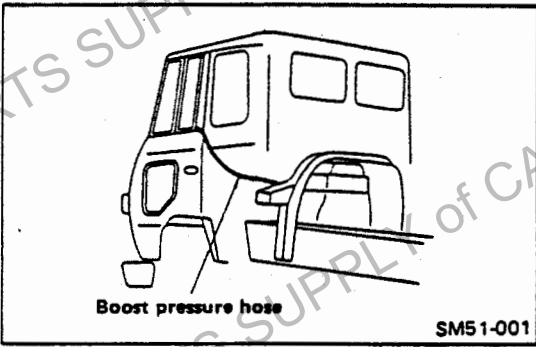

2. Disengage the clutch and run the engine at maximum rpm.

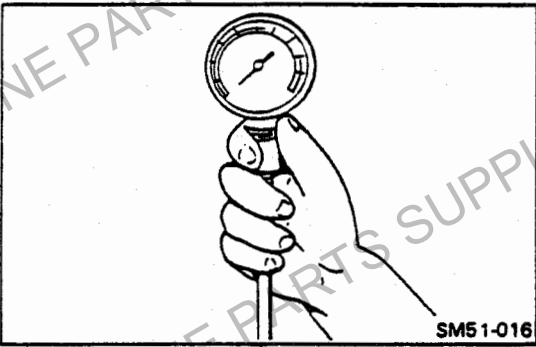

3. Read boost pressure.
If the boost pressure is below the normal value, turbocharger overhaul is needed.

Boost Pressure: Less than 0.16 kg/cm²

OTHER FACTORS

1. Noisy of excessive vibration of the turbocharger.
2. Excessive engine oil consumption.
3. Gas leakage at the turbine end or blower end.
4. Oil leakage from the turbocharger.

SPECIAL TOOL

Prior to starting an turbocharger overhaul, it is necessary to have these special tools.

ATTACHMENT FOR MEASURING TURBINE SHAFT RADIAL PLAY

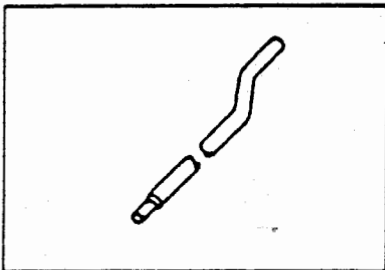

09444-1230

BOOST PRESSURE GAUGE

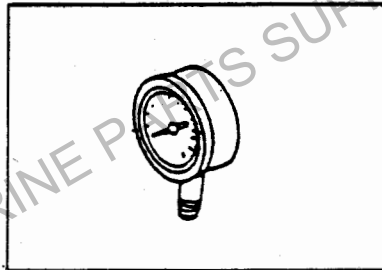

09444-1250

BOOST PRESSURE GAUGE HOSE

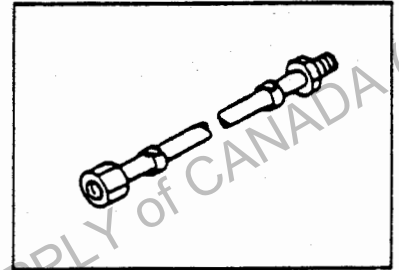

17108-1040

TURBOCHARGER

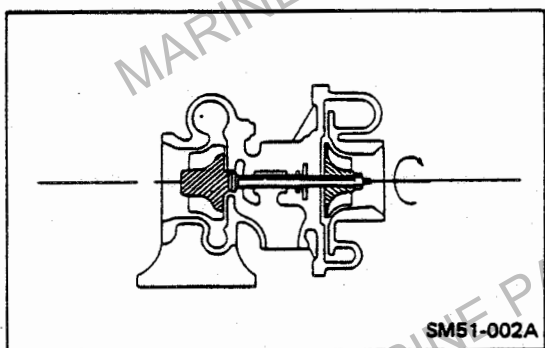
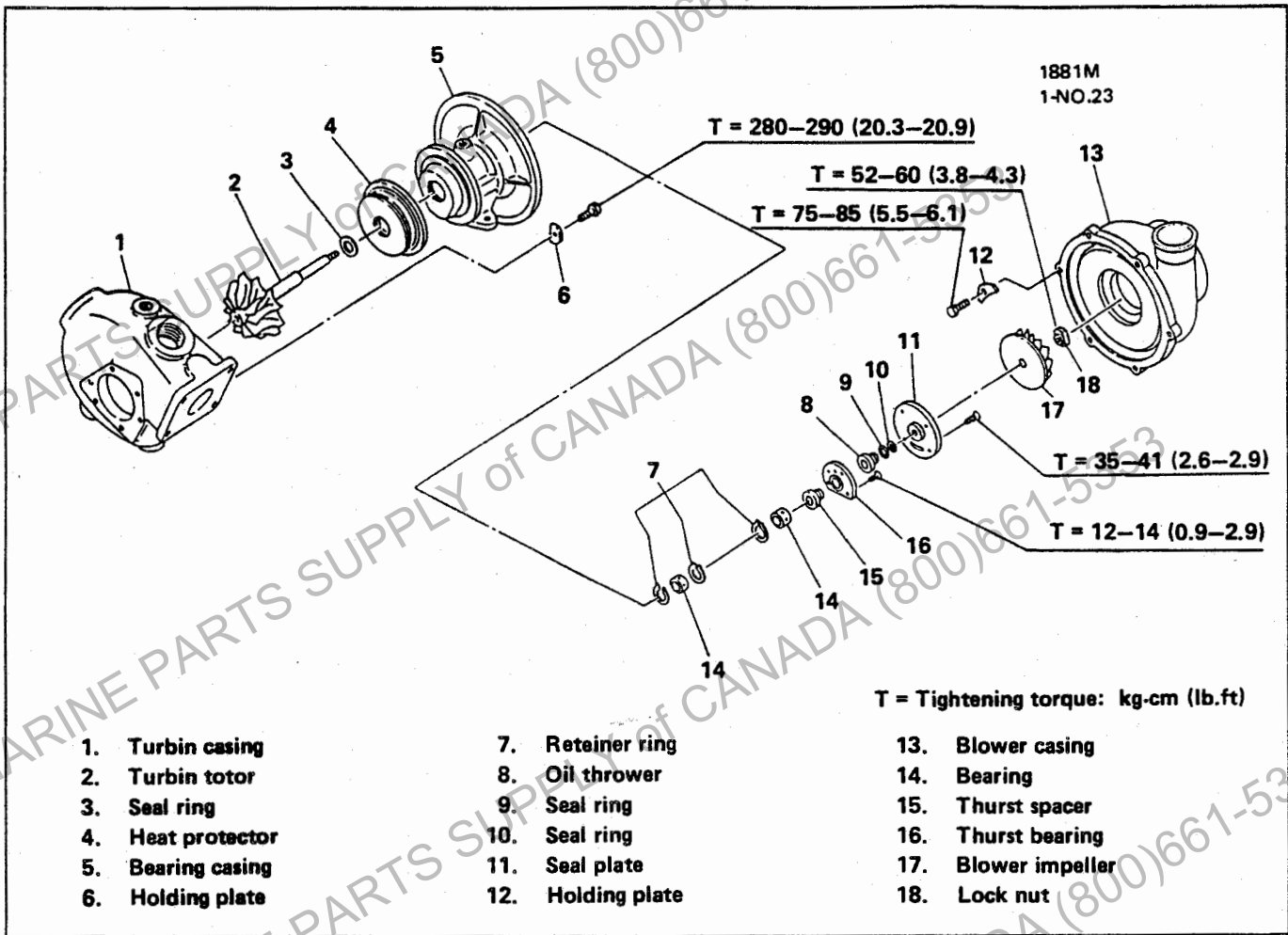

IMPORTANT POINT (S) – BEFORE DISASSEMBLY

1. Rotate the blower impeller by hand to see if it turns smoothly. If it does not turn smoothly, clean and inspect the bearing and turbine rotor.

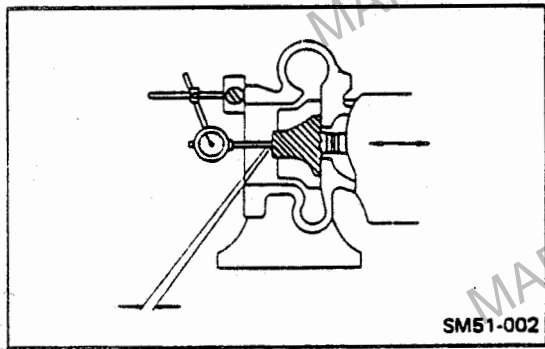

2. Check the turbine rotor for axial play (A). If the axial play is greater than the service limit, replace the thrust bearing and/or thrust spacer.

Axial Play: 0.06 – 0.09 mm (0.0024 – 0.0035 in)
Service Limit: 0.11 mm (0.0043 in)

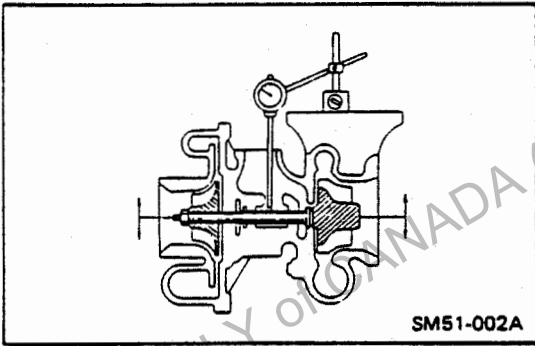

3. Check the turbine rotor for radial play using a special tool. If the radial play is greater than the service limit, replace the bearings and/or turbine rotor.

Special Tool: 09444-1230

Radial Play: 0.11 – 0.18 mm (0.0043 – 0.0070 in)

Service Limit: 0.215 mm (0.0084 in)

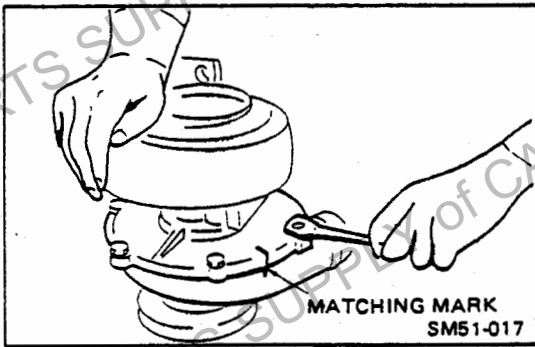

IMPORTANT POINT (S) – DISASSEMBLY

REMOVE THE BLOWER CASING AND TURBINE CASING.

- NOTE:
- Make matching marks on the each case and bearing case to aid alignment during reassembly.
 - If the blower casing cannot easily be removed by hand, tap it carefully all around using a plastic hammer and carefully remove it.
 - Be careful not to damage the blower impeller.

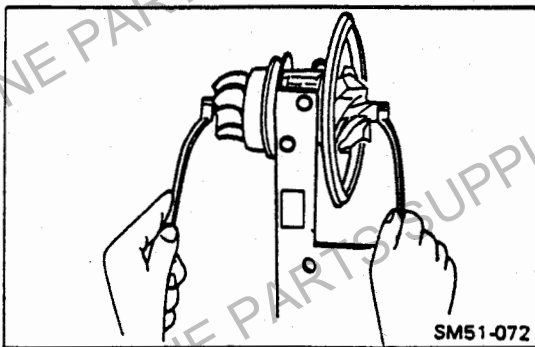

REMOVE THE TURBINE ROTOR.

1. Remove the blower impeller fitting nut.

NOTE: Turn the lock nut to clockwise to loosen the nut (left-hand threads).

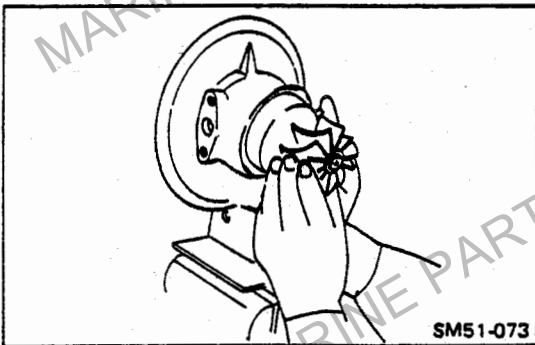

2. Remove the blower impeller and the turbine rotor with heat protector.

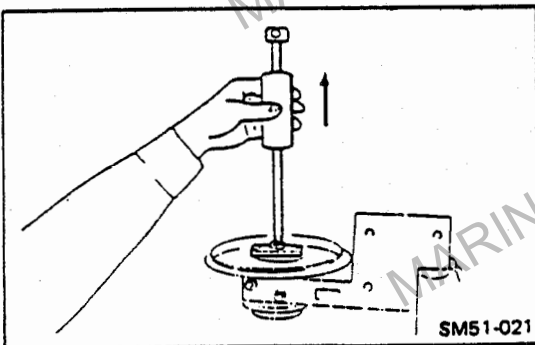

REMOVAL OF BEARINGS

1. Remove the seal plate.
Pull out the seal plate used by special tool.

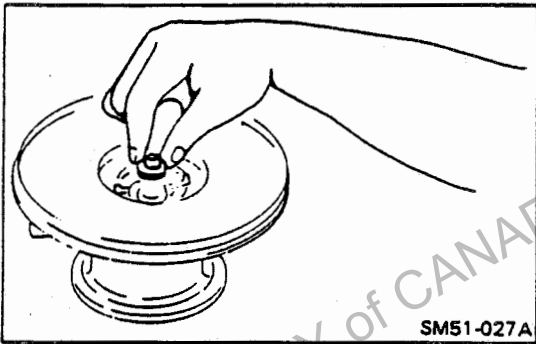

2. Remove the oil thrower.

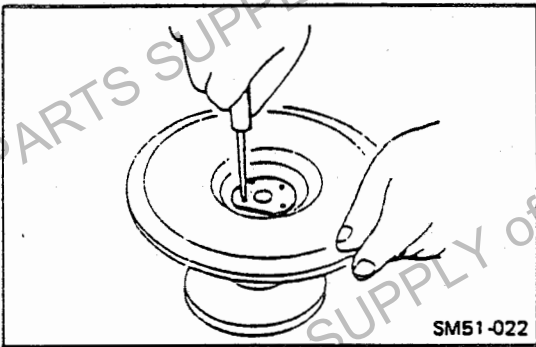

3. Remove the thrust bearing and thrust spacer.
Loosen the bolt, then remove the thrust bushing using a 10 dia. copper rod.

NOTE: When removing the thrust bearing and thrust spacer, be careful not to damage the thrust bearing hole in the bearing case.

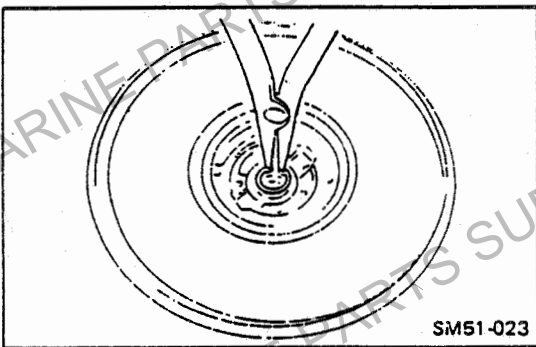

4. Remove the retainer rings of each bearing.

NOTE: When removing the retainer ring, be careful not to damage the front face of the hole in the bearing case.

5. Remove the bearings.

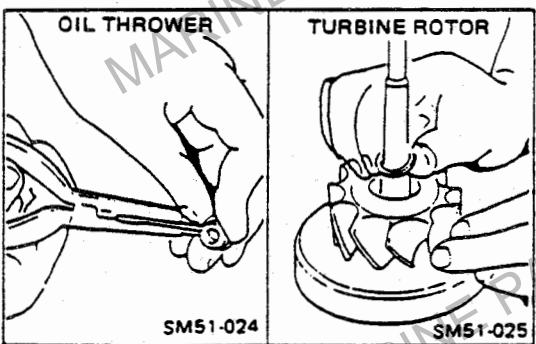

REMOVE THE SEAL RINGS.

NOTE: When removing the seal ring, be very careful not to damage the groove of the seal ring.

IMPORTANT POINT (S) — ASSEMBLY

CLEAN ALL PARTS.

1. Before cleaning, the disassembled parts should be visually inspected to check for burning, abrasion, carbon deposits, gas and oil leakage.
2. Thoroughly clean all the parts with diesel fuel, using a soft brush, and dry with compressed air.

NOTE: ○ Never use a caustic cleaning solution, as it may attack aluminum.

- Never use a wire brush.

ASSEMBLE THE JOURNAL BEARINGS.

1. Install the first retainer ring in the bearing casing.

NOTE: ○ Bevelled edge of the retainer ring should be towards the bearing.

- Make sure that the retainer ring is securely fitted in the groove.

- Install the retainer ring with the gap facing as shown in the drawing.

2. Install the bearing in the bearing case.

NOTE: Apply clean engine oil.

3. Install the other retainer ring.

NOTE: The only nearest turbine side of the retainer ring should be installed according to the figure on the left.

4. Repeat step 1) through 4) to install the second bearing.

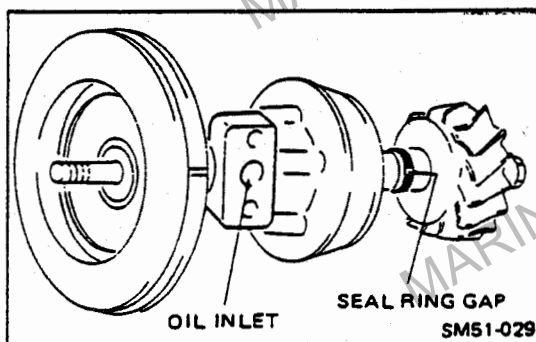
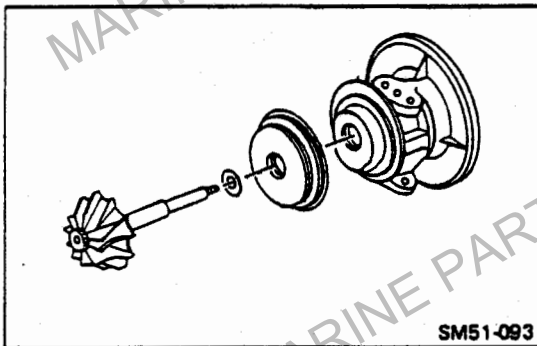
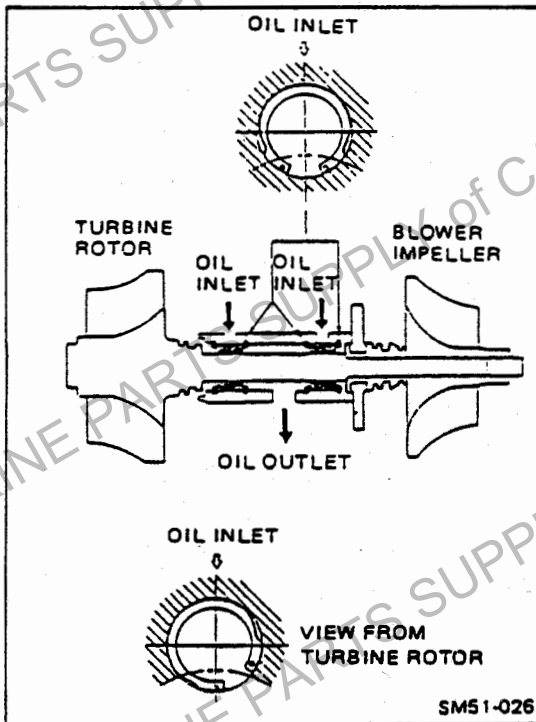

ASSEMBLE THE TURBINE ROTOR.

1. Install a new seal ring in the seal ring groove of the turbine shaft.

2. Position the heat protector on the bearing case.

3. Coat the journals of the turbine rotor with clean engine oil and install the turbine rotor in the bearing case.

NOTE: ○ The gap in the seal ring of the turbine shaft must face towards the oil inlet.

- Insert the seal ring concentric with the turbine shaft. If it is inserted with unreasonable force, it may be damaged.

- When inserting the turbine shaft, be very careful not to damage the journal bearing.

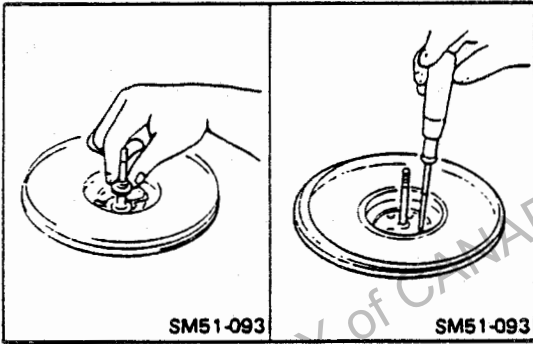
**ASSEMBLE THE THRUST BEARING.**

1. Install the thrust bush on the turbine shaft.

NOTE: Lubricate thrust bush surface.

2. Coat the thrust bearing with clean engine oil and install the thrust bearing.

NOTE: Always use new screws and lock washers.

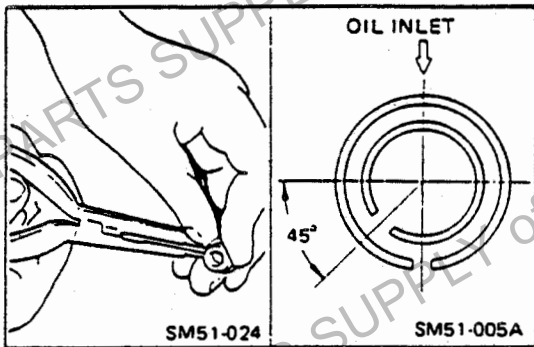
**INSTALL THE BACK PLATE.**

1. Insert two new seal rings on the oil thrower.
2. Install the oil thrower in the back plate.

NOTE: The openings of seal rings should be positioned as shown.

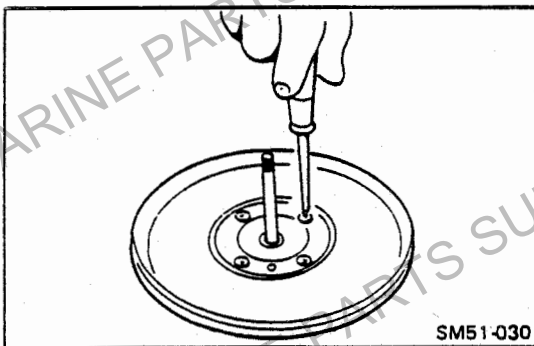

3. Install the back plate in the bearing plate.

NOTE: ○ The oil return hole should face the oil outlet side. Apply silicone R.T.V. sealer to the flanged surface of the back plate.

- Take care that the silicone sealer does not protrude from the flange.

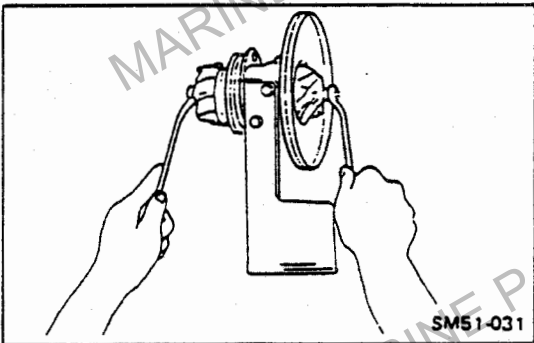
**FIT THE BLOWER IMPELLER ON THE TURBINE ROTOR AND TIGHTEN THE LOCK NUT.**

NOTE: Remember that this nut has left-hand threads.

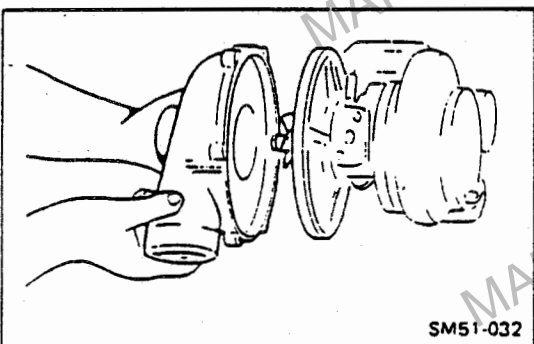
**INSTALL THE TURBINE CASE TO THE BEARING CASE, BEING SURE TO ALIGN THE MATCHING MARKS.****ASSEMBLE THE BLOWER CASE.**

1. Install the blower case to the bearing case referring to the matching marks.

NOTE: Coat the flange face of the blower case with silicone R.T.V. sealant.

2. Tighten the six fitting bolts.

ASSEMBLY TEST

1. Rotate the blower impeller by hand to see if it turns smoothly.
Refer to page TU-7.
2. Check the turbine rotor for axial play.
Refer to page TU-8.
3. Check the turbine rotor for radial play using a special tool.
Refer to page TU-8.

INSPECTION AND REPAIR

Unit: mm (in)

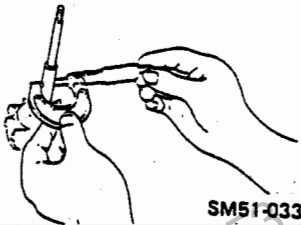
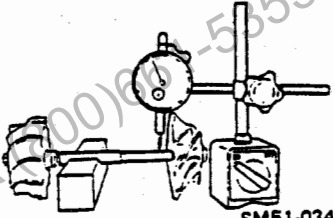
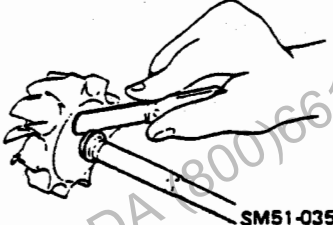
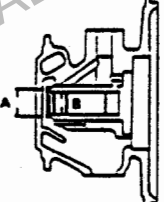
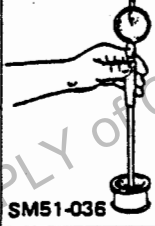
Inspection Item	Standard	Limit	Remedy	Inspection Procedure
Turbine Shaft Diameter	-	12.28 (0.4835)	Replace	 SM51-033
Turbine Shaft Bend	-	0.011 (0.0004)	Replace	 SM51-034
Seal Ring Groove Width of Turbine Shaft	-	1.63 (0.0642)	Replace shaft assembly.	 SM51-035
Bearing Case Inside Diameter	-	A: 18.55 (0.7303) B: 17.11 (0.6736)	Replace	 SM51-006
Journal Bearing Inside Diameter	-	12.36 (0.4866)	Replace	 SM51-036
Journal Bearing Outside Diameter	-	16.98 (0.6685)	Replace	

INSPECTION AND REPAIR

Unit: mm (in)

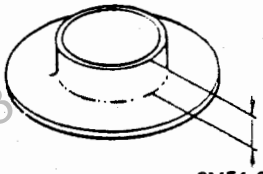
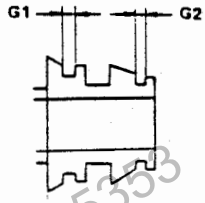
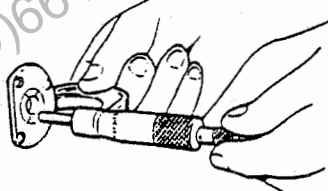
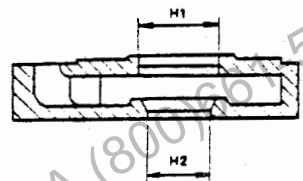
Inspection Item	Standard	Limit	Remedy	Inspection Procedure
Thrust Spacer Height	-	4.68 (0.1843)	Replace	 <p>SM51-007</p>
Seal Ring Groove Width of Oil Thrower	-	G1: 1.75 (0.0689) G2: 1.52 (0.0598)	Replace	 <p>SM51-006A</p>
Thrust Bearing Thickness	-	4.48 (0.1764)	Replace	 <p>SM51-038</p>
Sealing Bore of Seal Plate	-	H1: 16.05 (0.6319) H2: 14.05 (0.5531)	Replace	 <p>SM51-006B</p>

(KY)

CHAPTER IP

FUEL INJECTION PUMP

DESCRIPTION	IP- 2
TROUBLESHOOTING	IP- 3
SPECIAL TOOLS	IP- 6
INJECTION PUMP	IP- 7
TIMER	IP-15
FEED PUMP	IP-19
ADJUSTMENT	IP-21

DESCRIPTION

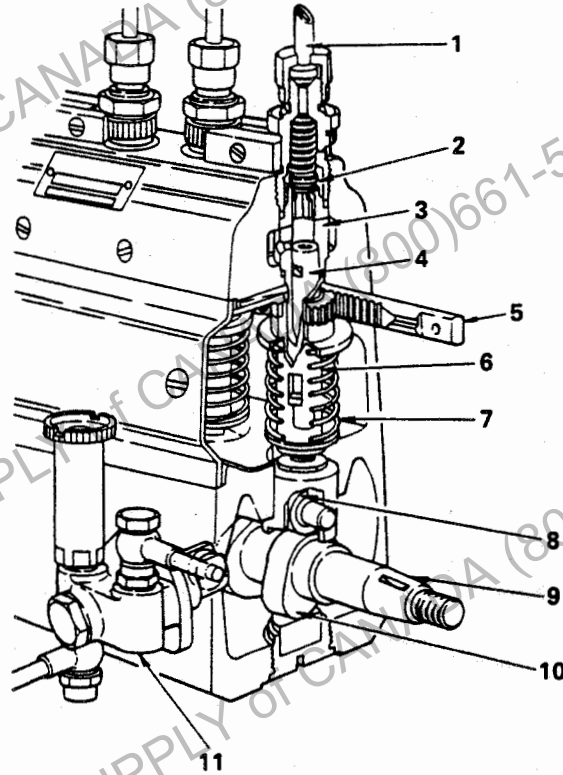

FUEL INJECTION PUMP

- 1. High pressure pipe
- 2. Delivery valve
- 3. Plunger barrel
- 4. Plunger

- 5. Control rod
- 6. Control sleeve
- 7. Plunger spring
- 8. Tappet

- 9. Cam shaft
- 10. Cam
- 11. Fuel feed pump

TROUBLESHOOTING

Symptom

Possible cause

Remedy/Prevention

Engine does not start

Fuel not reaching injection pump

- Fuel lines clogged or damaged Clean or replace fuel lines.
- Fuel filter clogged Clean or replace the filter element.
- Air in fuel caused by improper connections of fuel line between fuel tank and feed pump Repair connections.
- Filter incorporated in inlet side of feed pump clogged Remove foreign material.
- Faulty feed pump check valve Repair or replace it.
- Feed pump piston spring broken Replace it.
- Feed pump push rod or tappet sticking Repair or replace it.

Fuel reaching injection pump

- Faulty connection of accelerator wire to pump adjusting lever. Repair connection.
- Control rack faulty or sticking Repair it.
- Damaged camshaft bearing Repair it.
- Plunger worn or sticking Correct or replace it.
- Faulty connection of engine stop wire to pump stop lever. Repair it.

Nozzle faulty

- Fuel leakage caused by loosened nozzle holder. Inspect and tighten it.
- Low opening pressure of nozzle Adjust it.
- Nozzle pressure spring broken Replace it.
- Nozzle needle sticking to nozzle body Correct or replace it.

Pump out of timing

- Improperly retarded injection timing Correct injection timing.
- Incorrect timing caused by improper installation of pump Check engine timing and correct it.
- Woodruff key for pump camshaft cut off. Replace it.
- Improper pre-stroke adjustment Correct it to obtain specified injection timing.



Symptom	Possible cause	Remedy/Prevention
Excessive smoke	Black smoke	
	● Excessive fuel delivery caused by incorrect adjustment of fuel load stopper screw.	Adjust fuel delivery on test stand.
	● Excessively advanced injection timing.	Correct it.
	● Large spread in fuel delivery	Adjust it.
	● Bad nozzle fuel spray characteristics	Check and correct them.
	White smoke	
	● Improperly retarded injection timing.	Advance injection timing.
● Water in fuel	Check and clean fuel lines.	
Low idle speed irregular	Improper adjustment of idle button	Correct it.
	Bad fuel spray characteristic of nozzles.	Check and repair them.
	Incorrect injection timing	Correct it.
	Incorrect initial tension setting of idling spring or the spring broken.	Adjust or replace it.
	Control rack not smoothly move	Disassemble pump and repair it.
	Large spread in fuel delivery	Adjust it.
	Plunger worn	Replace it.
	Governor linkage not smoothly move.	Correct it.
Defective feed pump	Disassemble and repair it.	
Engine always runs at high speed	Accelerator cable sticking	Check and correct it.
	Governor linkage sticking	Disassemble and repair the governor.
	Control rack sticking	Check and correct it.
Engine starts and stops	Fuel lines clogged	Clean or replace fuel lines.
	Air in fuel caused by damaged fuel lines or improper connection of fuel lines.	Repair fuel lines or replace fuel lines and gaskets.

Symptom

Possible cause

Remedy/Prevention

Engine has low power

Pump out of timing

- Excessive advanced timing, resulting in loud knocking. Check and correct it.
- Excessively retarded timing resulting in black smoke. Check and correct it.
- Defective injection pump overflow valve. Repair or replace it.
- Feed pressure too low Repair the feed pump.
- Improper accelerator cable adjustment Adjust it.

Nozzle faulty

- Fuel leakage from nozzle holder Check and repair nozzle holder.
- Bad nozzle spray characteristic Repair or replace it.
- Loosened adjusting screw in nozzle holder, resulting in low opening pressure. Adjust it.
- Nozzle pressure spring broken Replace it.

Pump faulty

- Fuel leakage from delivery valve holder. Retighten the delivery valve holder if it is loosened or replace O-ring if the O-ring is defective.
- Defective seat of delivery valve assembly. Repair or replace it.
- Delivery valve spring broken Replace the spring.
- Plunger worn Replace it.
- Large spread in fuel delivery Adjust it.
- Wear of tappet roller Replace the roller.
- Camshaft bearing worn or broken Replace it.
- Improper adjustment of governor fuel load stopper screw. Adjust it.

Loud knocking

- Improper injection timing Correct it.
- Bad fuel nozzle spray pattern after-dribble. Check and correct it.
- High nozzle opening pressure Adjust the opening pressure.
- Incorrect fuel deliveries to some nozzles. Readjust the fuel deliveries.

SPECIAL TOOL

Prior to starting an injection pump overhaul, it is necessary to have these special tools.

PLUNGER CLAMP

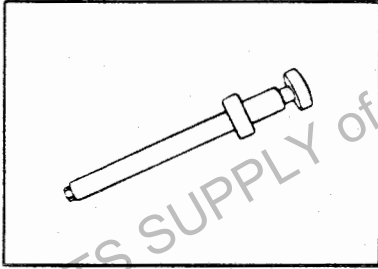

09512-1360

TAPPET CLAMP

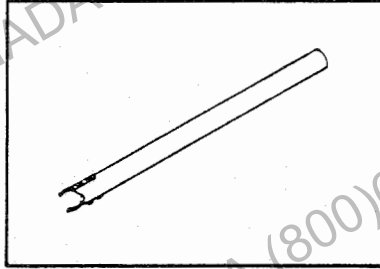

09512-1120

TAPPET ROLLER CLAMP

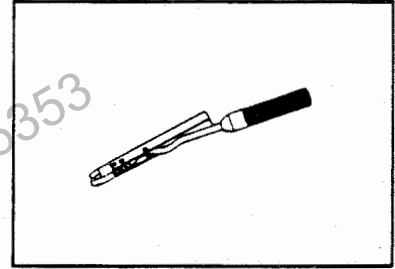

09512-1130

CAMSHAFT BEARING OUTER RACE PULLER

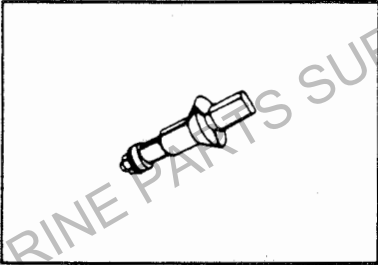

09512-1160 (REAR)
09512-1430 (FRONT)

TAPPET INSERTER

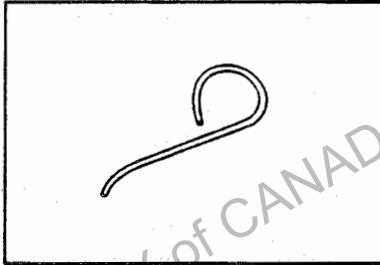

09512-1380

CAMSHAFT CLEARANCE GAUGE

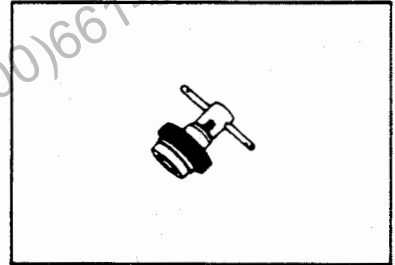

09512-1150

SPRING HOLDER

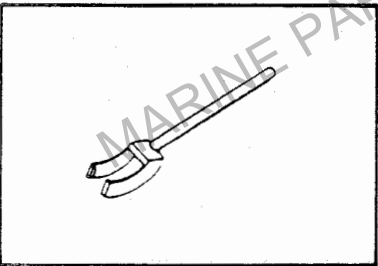

09512-1370

TAPPET GAP INSTRUMENT

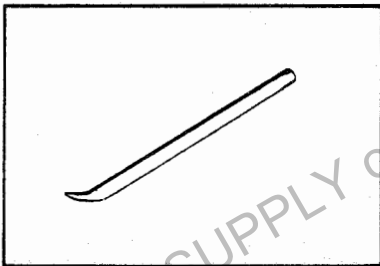

09512-1410

HOLDING WRENCH

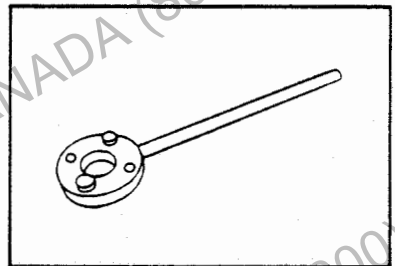

09512-1710

TIMER EXTRACTOR

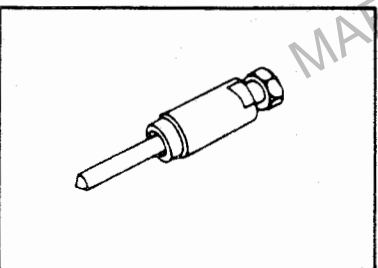

09512-1230 (SA-TYPE)
09512-1280 (SCZ-TYPE)

SPRING HOLDER

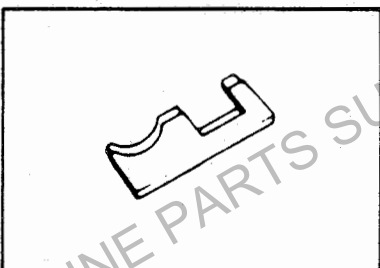

09512-1240

INJECTION PUMP

A-TYPE PUMP

[4-CYLINDER]

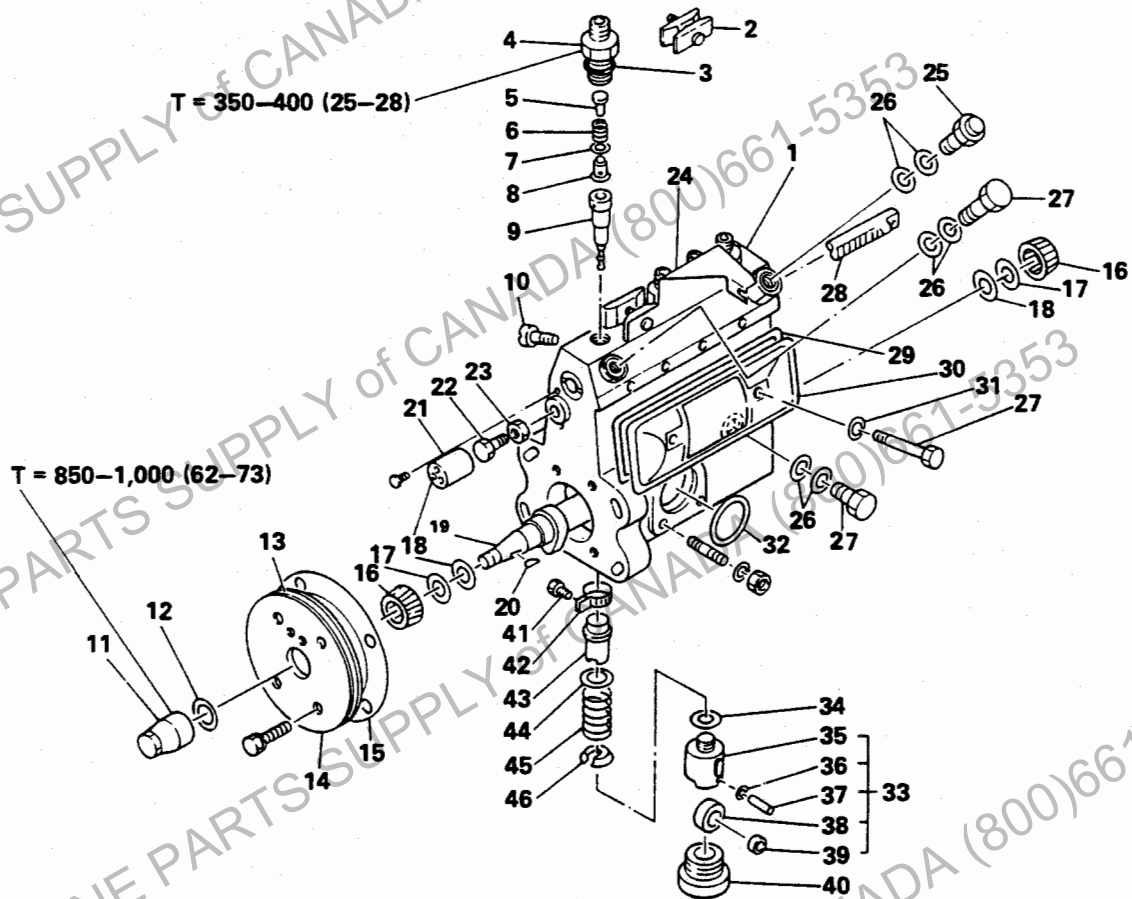

- 1. Injection pump housing
- 2. Lock plate
- 3. O-ring
- 4. Delivery valve holder
- 5. Stopper
- 6. Delivery valve spring
- 7. Gasket
- 8. Delivery valve
- 9. Plunger
- 10. Screw
- 11. Nut
- 12. O-ring
- 13. O-ring
- 14. Bearing cover
- 15. Gasket
- 16. Taper roller bearing

- 17. Shim
- 18. Adjusting ring
- 19. Camshaft
- 20. Woodruff key
- 21. Control rod cover
- 22. Bolt
- 23. Nut
- 24. Stop wire bracket
- 25. Overflow valve sub-assembly
- 26. Special washer
- 27. Bolt
- 28. Control rod
- 29. Cover gasket
- 30. Cover
- 31. Plain washer
- 32. O-ring

T = Tightening torque kg-cm (lb.ft)

- 33. Tappet assembly
- 34. Shim
- 35. Tappet
- 36. Retainer ring
- 37. Tappet roller pin
- 38. Tappet roller
- 39. Roller bushing
- 40. Plug
- 41. Screw
- 42. Control pinion
- 43. Control sleeve
- 44. Plunger spring seat, upper
- 45. Plunger spring
- 46. Plunger spring seat, lower

A-TYPE

[6-CYLINDER]

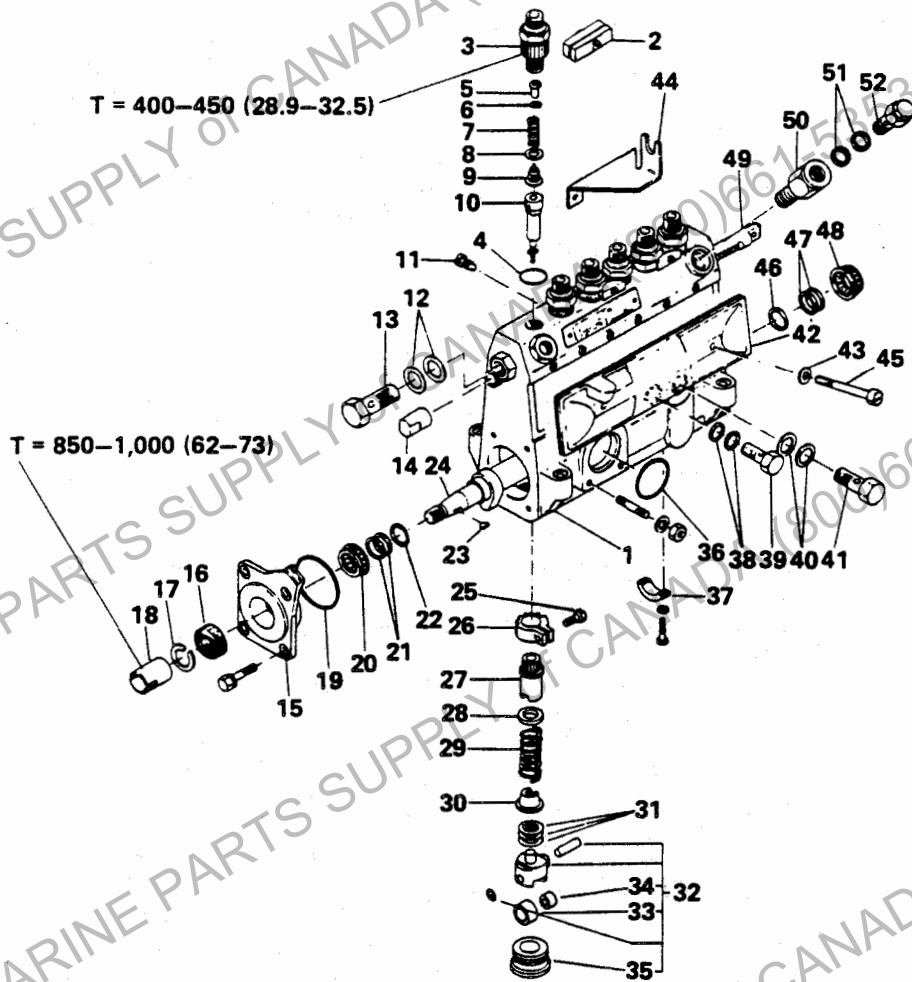

T = Tightening torque kg-cm (lb.ft)

- | | | |
|---------------------------|--------------------------------|----------------------------------|
| 1. Injection pump housing | 19. O-ring | 37. Center bearing |
| 2. Lock plate | 20. Taper roller bearing | 38. Washer |
| 3. Delivery valve holder | 21. Shim | 39. Hollow screw |
| 4. O-ring | 22. Adjusting ring | 40. Washer |
| 5. Stopper | 23. Woodruff key | 41. Hollow screw |
| 6. Plate washer | 24. Camshaft | 42. Cover |
| 7. Delivery valve spring | 25. Screw | 43. Gasket |
| 8. Gasket | 26. Control pinion | 44. Stop wire bracket |
| 9. Delivery valve | 27. Control sleeve | 45. Bolt |
| 10. Plunger | 28. Plunger spring seat, upper | 46. Adjusting ring |
| 11. Screw | 29. Plunger spring | 47. Shim |
| 12. Washer | 30. Plunger spring seat, lower | 48. Taper roller bearing |
| 13. Hollow screw | 31. Shim | 49. Control rack |
| 14. Control rack cover | 32. Tappet assembly | 50. Adapter |
| 15. Bearing cover | 33. Tappet roller | 51. Washer |
| 16. Oil seal | 34. Roller bushing | 52. Over flow valve sub-assembly |
| 17. Spring washer | 35. Plug | |
| 18. Round nut | 36. O-ring | |

IMPORTANT POINT (S) – DISASSEMBLY

WARNING

- Breaking of the lead seals or crimp caps by anyone other than HINO or pump manufacture authorized service stations to make these adjustment will void the warranty.
- If fuel pump or governor difficulties are suspected, consult only HINO or pump manufacture authorized service stations, where the problem can be corrected and the injection pump lead seals and crimp caps can be reinstalled as required.
- Measure and record the fuel delivery characteristics of the pump before disassembling it.
- Keep the parts for each cylinder in separate groups and in an orderly arrangement. Parts to be replaced and parts to be used again must be kept separately.

REMOVE THE TIMER ASSEMBLY.

Refer to "TIMER AND COUPLING".

REMOVE THE GOVERNOR.

Refer to "GOVERNOR".

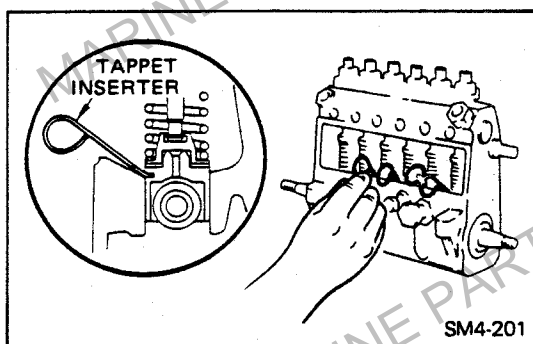

INSERT THE TAPPET INSERTER IN THE TAPPET HOLE.

Turn the camshaft and insert the tappet inserters in each tappet hole when their tappet is at the highest position.

Special Tool: Tappet Inserter (09512-1380)

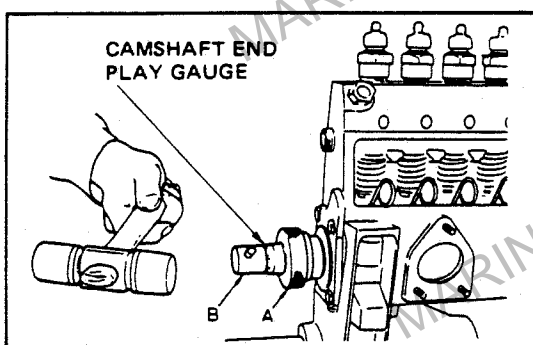

MEASURE THE CAMSHAFT END PLAY.

1. Mount the camshaft end play gauge on the camshaft drive end and be sure tighten "B".

Special Tool: Camshaft End Play Gauge (09512-1150)

2. By turning "A", create a clearance of about 1 mm (0.04in) between "A" and the bearing cover.
3. Lightly strike the end "B" 3 or 4 times with a plastic hammer.

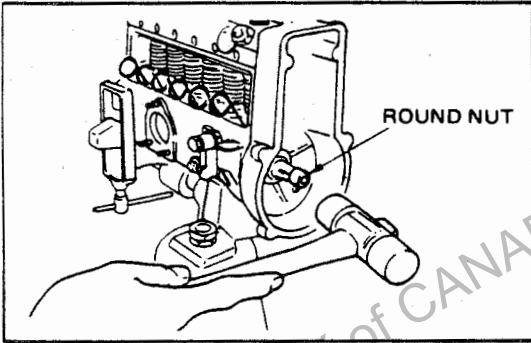

4. Lightly tighten "A" until it comes into contact with the bearing cover.
5. Lightly strike the camshaft governor end 3 or 4 times a plastic hammer.

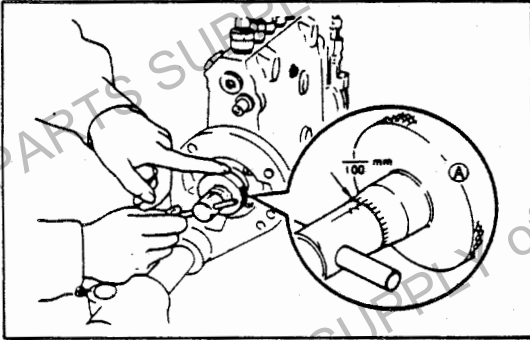

6. Lightly turn "A" until it comes into contact with the bearing cover, then read the clearance.

Assembly Standard: 0.03–0.05 mm (0.0012–0.0019 in)
Service Limit: 0.10 mm (0.004 in)

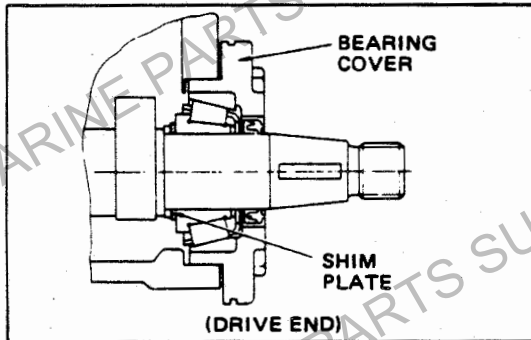

7. If the specification is not met, use appropriate shim plates at the drive end of camshaft.

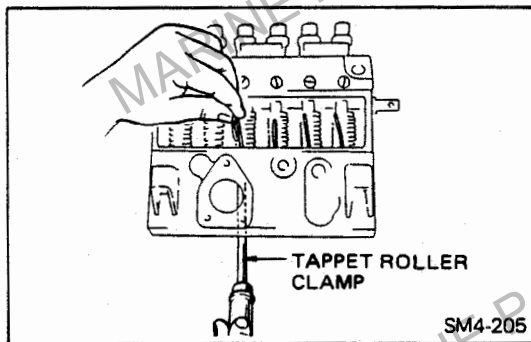

REMOVE THE TAPPET ASSEMBLY.

1. Push the tappet with the tappet roller clamp and remove the tappet inspector.

Special Tool: Tappet Roller Clamp (09512-1130)

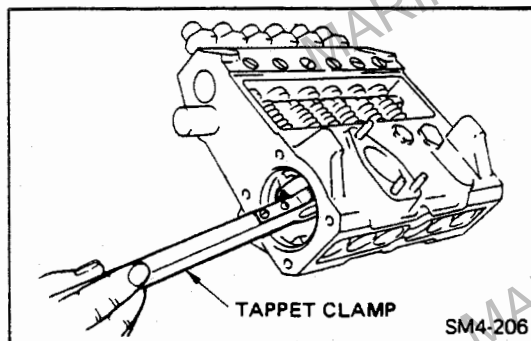

2. Remove the tappet through the camshaft bearing hole.

Special Tool: Tappet Clamp (09512-1120)

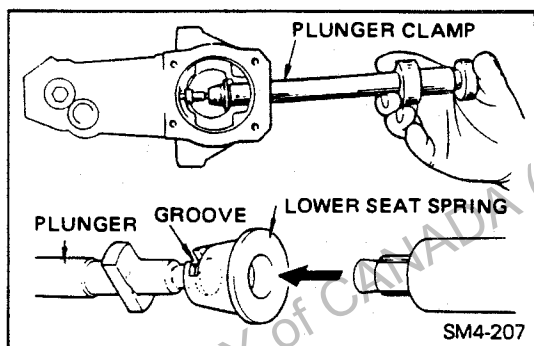

REMOVE THE PLUNGERS, SPRINGS AND CONTROL SLEEVE.

1. Use the plunger clamp hold the spring lower seat and remove it together with the plunger.

Special Tool: Plunger Clamp (09512-1360)

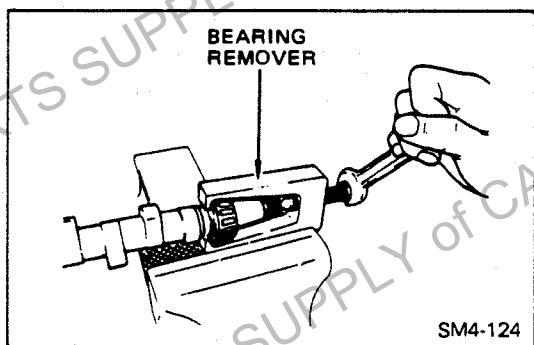

REMOVE THE TAPER BEARING FROM THE CAMSHAFT.

1. Remove the taper bearing from the drive end of the camshaft.

Special Tool: Bearing Remover (09510-1160)

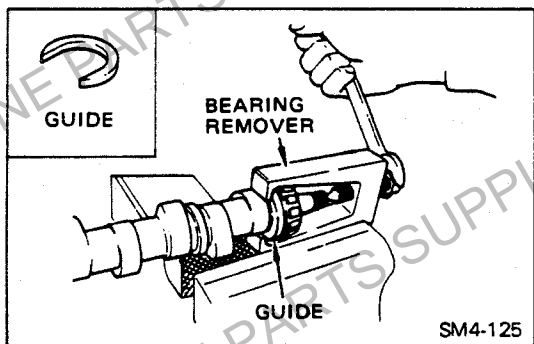

2. Use the guide to remove the bearing at the governor side.

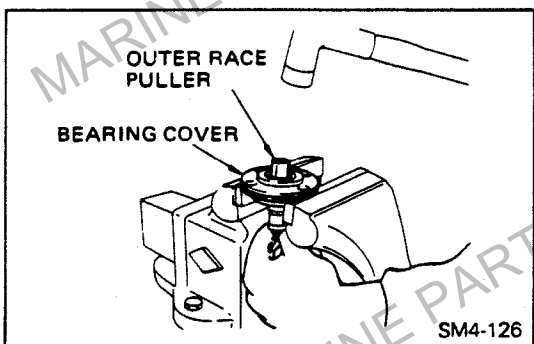

3. Use the outer race puller, to tap out the outer race in the bearing cover.

Special Tool: Outer Race Puller (09512-1430)

IMPORTANT POINT (S) – ASSEMBLY

WARNING

- Wash all parts with clean diesel fuel before installing them, and any defective or damaged parts must be replaced.
- Do not allow dust or other foreign matter to enter the pump during assembly.
- Apply grease to O-rings and oil seals before installing them.
- Assemble the parts in correct order and to correct tightening torques, assembled dimensions etc.
- Assembly takes place in the reverse order of disassembly.

INSTALL THE PLUNGER BARRELS.

1. Before install the plunger barrels should be inspect the plunger barrels and plungers for wear, scratches, or discoloration.

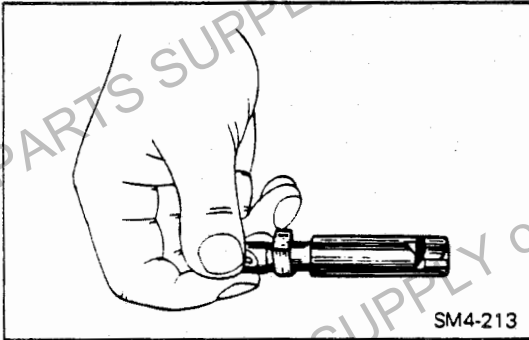

2. Tilt the plunger to about 60°. Pull the plunger out approximately 10 to 15 mm (0.39–0.59 in) and release it to see if it slides down smoothly from its own weight.

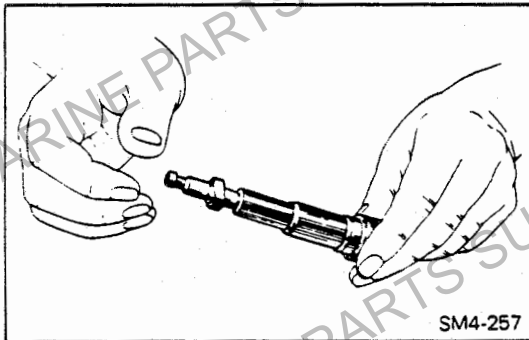

3. Match the plunger notch with the injection pump housing knock pin.

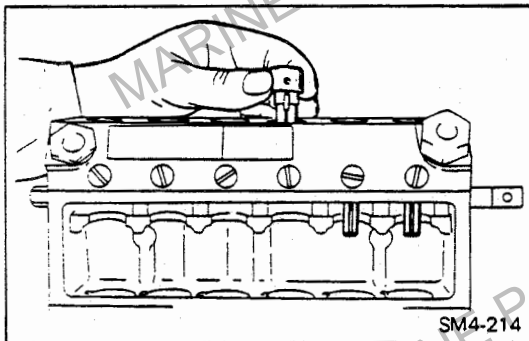

INSTALL THE DELIVERY VALVES, SPRINGS AND HOLDERS.

1. Before install the delivery valves, inspect the delivery valves for scratches on the valve seat or the piston sections.

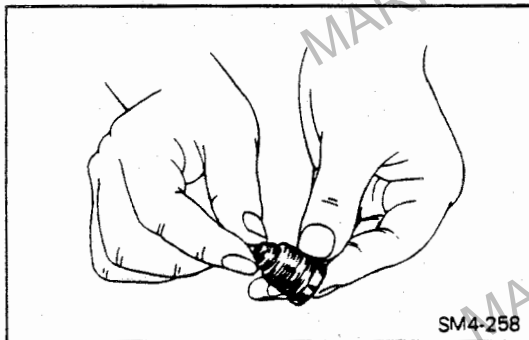

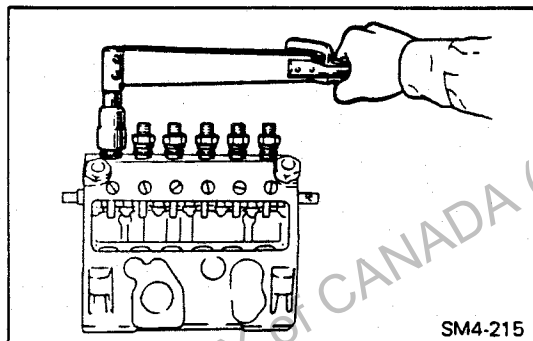

2. Install the gasket, spring, shim and stopper on the delivery valve.
3. Provisionally tighten the delivery valve holder with a new O-ring by hand.

NOTE: Tighten the delivery valve holder after installing the plunger.

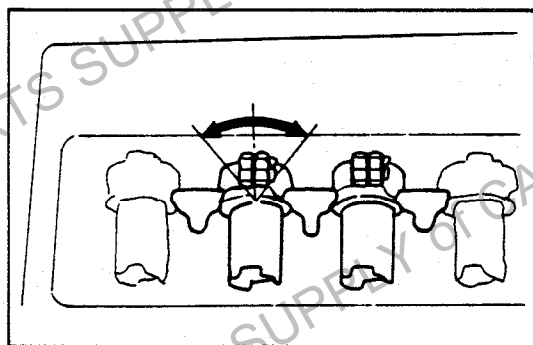

INSTALL THE CONTROL SLEEVES ON THE BARRELS.

NOTE: Make sure that the control sleeve swings evenly right and left when the control rack is moved to the right and left.

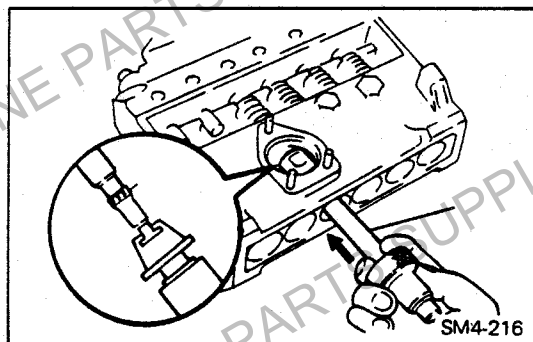

INSTALL THE PLUNGER AND TAPPET.

1. Assembly the plunger and spring lower seat, inserting the driving face marked with a number and the lower seat notch part upward (cover plate side).

Special Tool: Plunger Clamp (09512-1360)

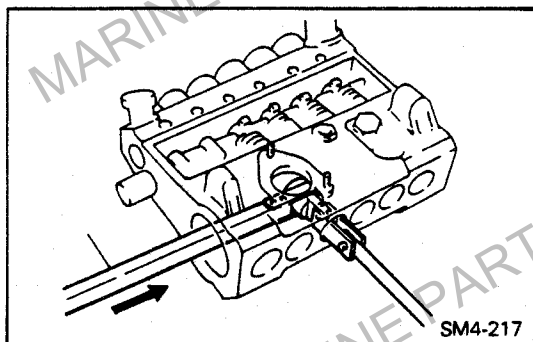

2. Install the tappet to the pump housing with the adjusting shim.

Special Tool: Tappet Roller Clamp (09512-1130)
Tappet Clamp (09512-1120)

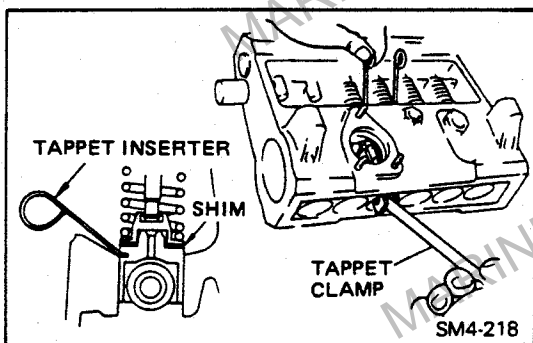

3. Using the tappet roller clamp to press in the tappet and hold it in with the tappet inserter.

Special Tool: Tappet Inserter (09512-1380)

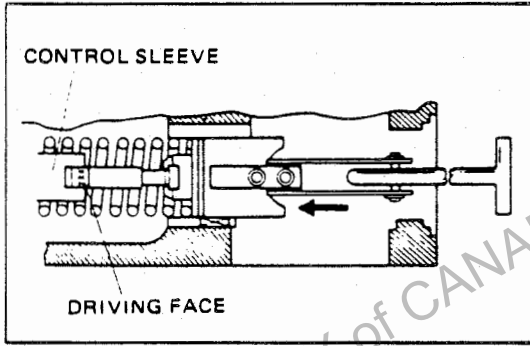

- NOTE:**
- Check that the driving face of the plunger fits to the groove of the control sleeve before inserting the tappet.
 - When inserting the tappet, check that the control rack slides smoothly and without catching.

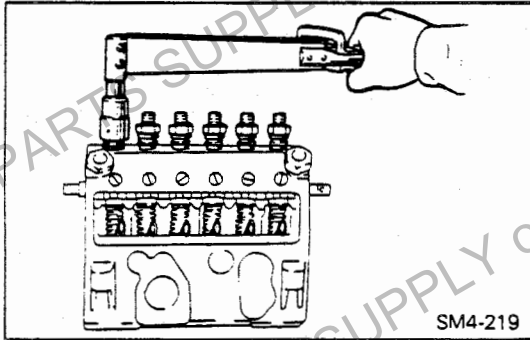

TIGHTEN THE DELIVERY VALVE HOLDER.

When one delivery valve holder is tightened, move the control rack to the right and left and inspect the tightness of the rack.

Tightening Torque: 400–450 kg-cm (29–32 lb.ft)

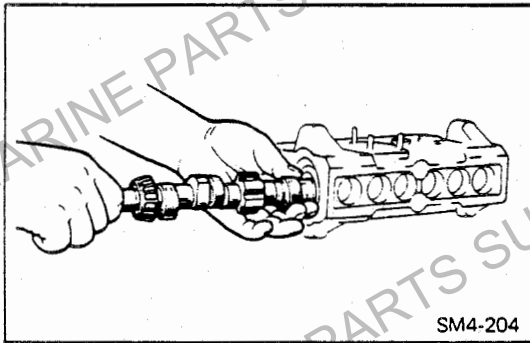



INSTALL THE CAMSHAFT WITH CENTER BEARING.

Place a small amount of oil or grease on the center bearing to hold it to camshaft and then install the camshaft in the pump housing.

NOTE: A-TYPE 4-cylinder pump is without center bearing.

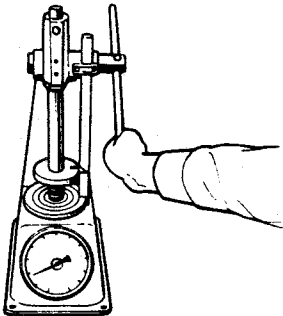
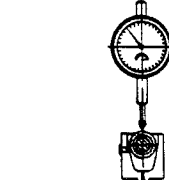
INSPECTION AND REPAIR

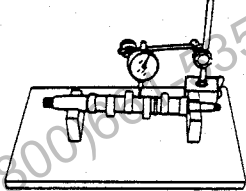
Inspection Item	Standard	Limit	Remedy	Inspection Procedure
Plunger springs tension.	24.4 kg (49.4 lb) at 41.4 mm (1.63 in)	21.0 kg (46.3 lb)	Replace, spring.	
Delivery valve springs tension.	3.1 kg (6.8 lb) at 17.0 mm (0.67 in)	2.7 kg (6.0 lb)	Replace, spring.	
Tappet wear.		0.3 mm (0.012 in)	Replace, tappet assembly.	
Camshaft run-out.		0.15 mm (0.006 in)	Replace, camshaft.	

TIMER

SA-TYPE TIMER

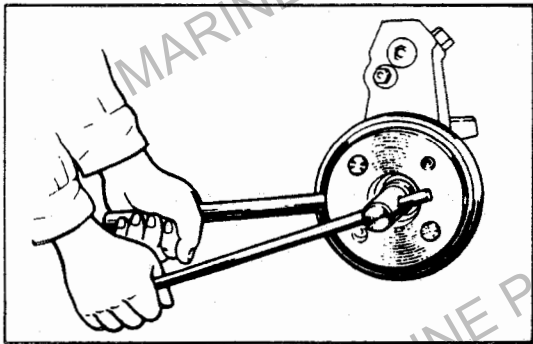
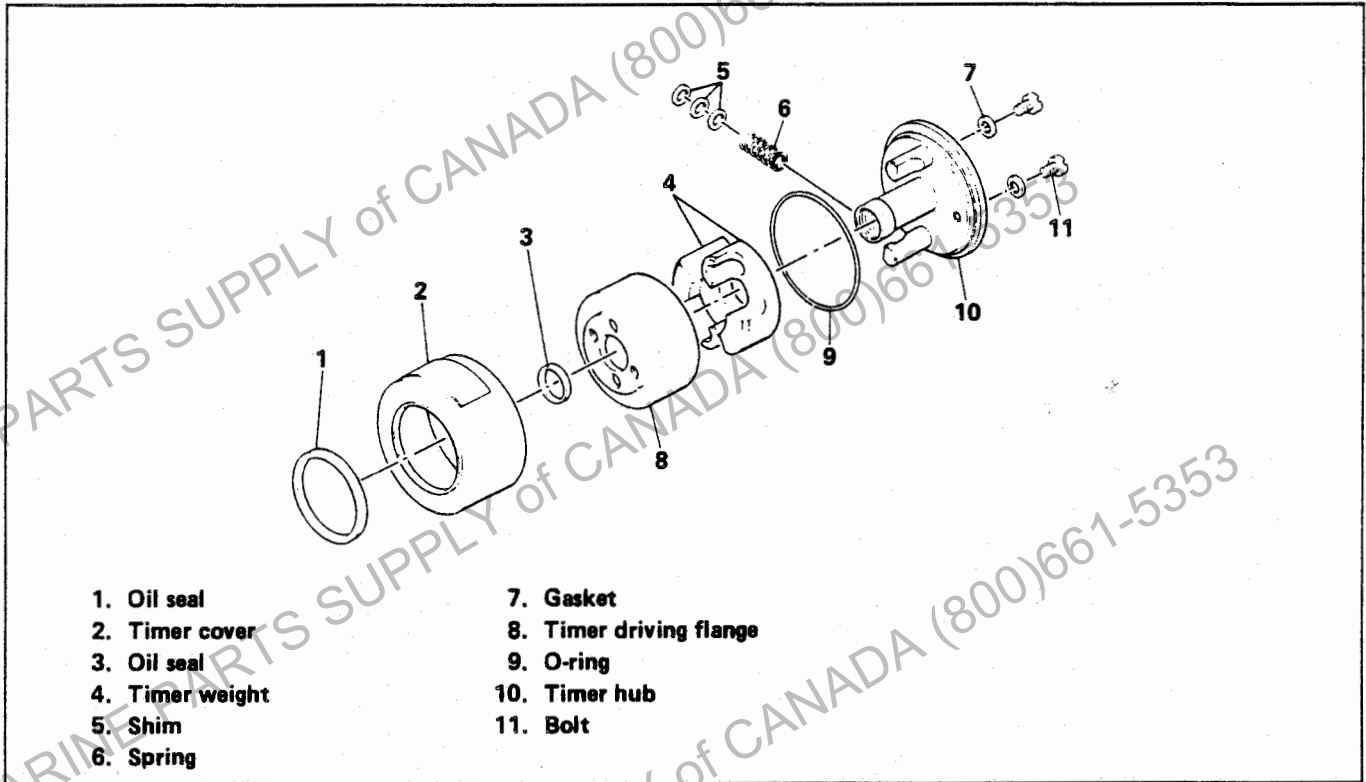

IMPORTANT POINT (S) – DISMOUNTING

REMOVE THE TIMER FROM THE INJECTION PUMP.

1. Remove the timer round nut from the timer.

Special Tool: Holding Wrench (09512-1710)

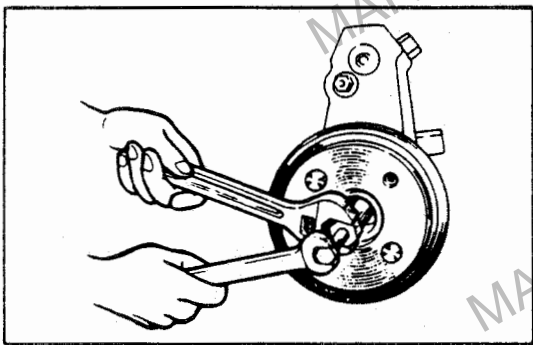

2. Remove the timer from the injection pump.

Special Tool: Timer Extractor (09512-1230)

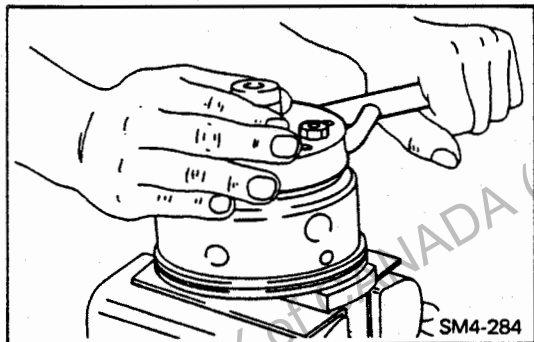

IMPORTANT POINT (S) – DISASSEMBLY

Slightly turning the driving flange counterclockwise to remove it.

Special Tool: Holding Wrench (09512-1710)

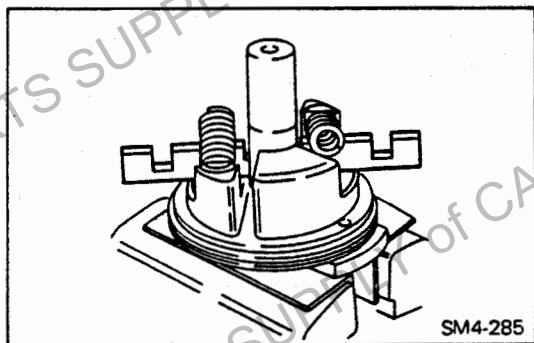

IMPORTANT POINT (S) – ASSEMBLY

INSTALL THE FLYWEIGHTS AND THE SPRINGS.

Place the flyweights, springs and the shims in correct location on the timer hub.

The spring guides must be placed under the springs to support the latter during assembling.

Special Tool: Spring Guide (09512-1240)

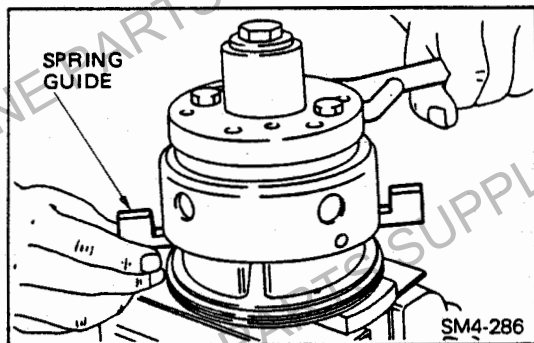

INSTALL THE TIMER DRIVING FLANGE.

Slightly turning the driving flange counterclockwise to compress the springs with the holding tool and remove the spring guides, install the driving flange to the timer hub.

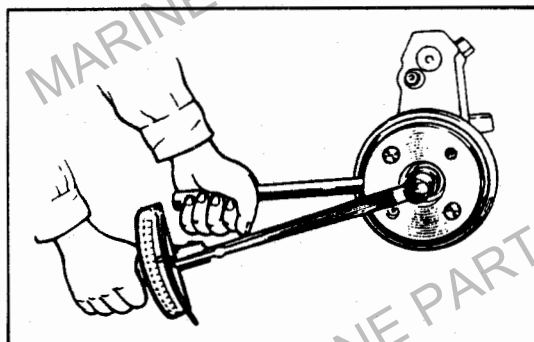

IMPORTANT POINT (S) – MOUNTING

MOUNT THE TIMER ON THE INJECTION PUMP HOUSING.

Special Tool: Holding Wrench (09512-1710)

Tightening Torque: 850–1,000 kg-cm (62–72 lb.ft)

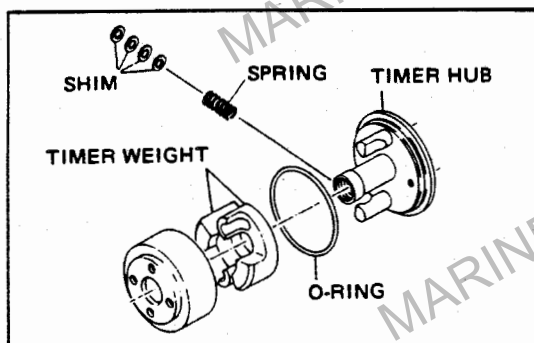

ADJUSTMENT OF THE TIMER

INSPECT THE TIMER ADVANCE.

1. Set a stroboscope on a pump tester.
2. Check the timer advance.

Advance angle: Refer to "CALIBRATION chart".

If angle in not within specification, adjust with proper shim.

SCZ-TYPE TIMER

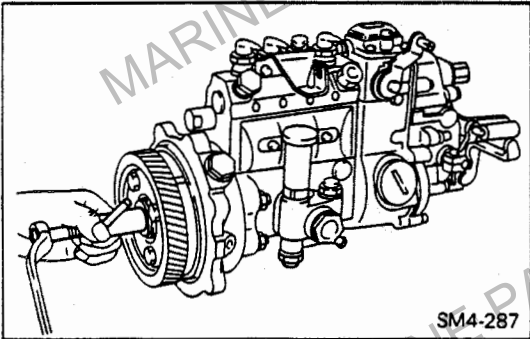
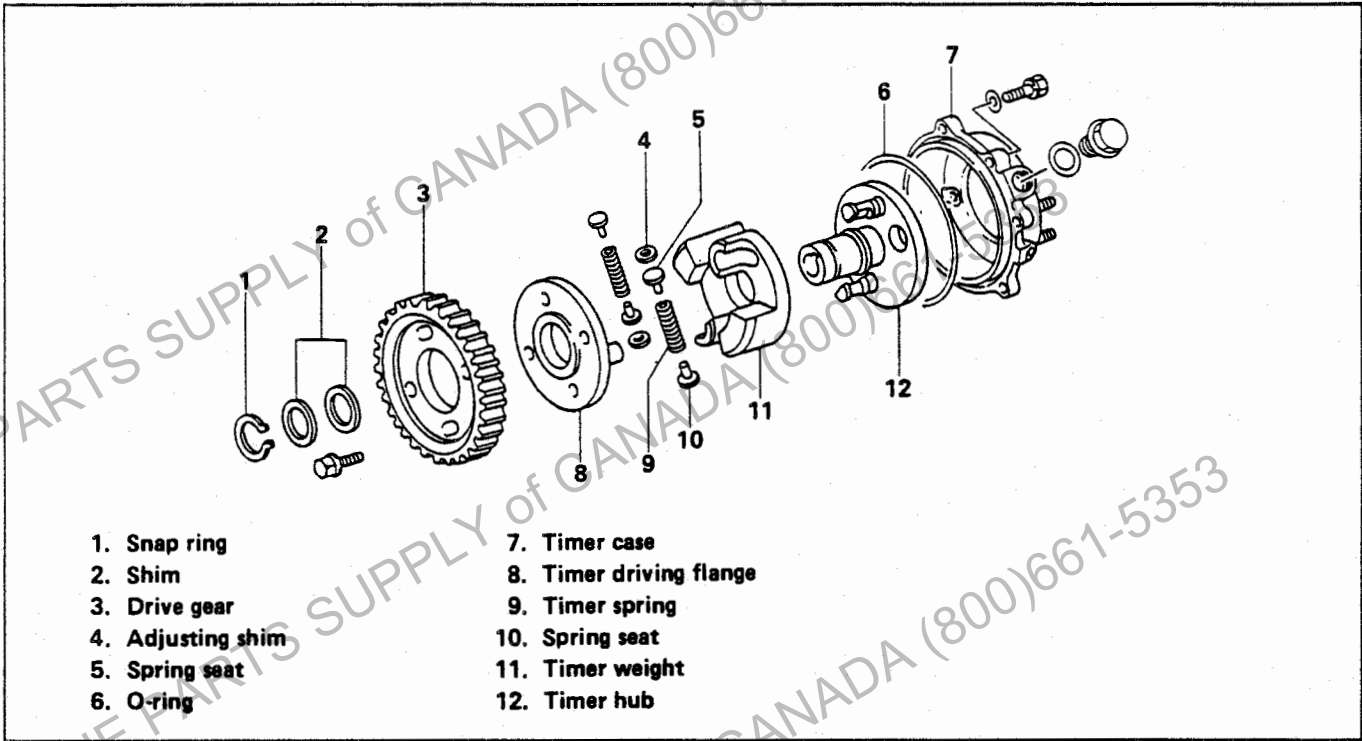

IMPORTANT POINT (S) – DISMOUNTING

REMOVE THE TIMER ASSEMBLY FROM INJECTION PUMP.

Special Tool: Timer Extractor (09512-1230)

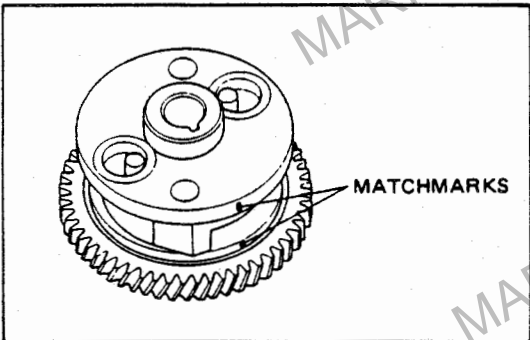

IMPORTANT POINT (S) – DISASSEMBLY

REMOVE THE DRIVE GEAR FROM TIMER.

NOTE: Place matchmarks on the timer flange and timer hub.

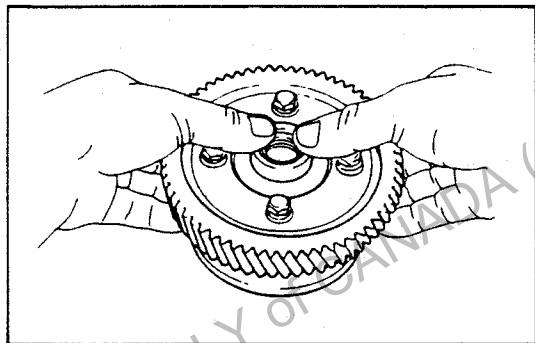

1. Remove the snap ring.
2. Pull up the timer flange.

NOTE: Be careful that the springs and shims do not fly out.

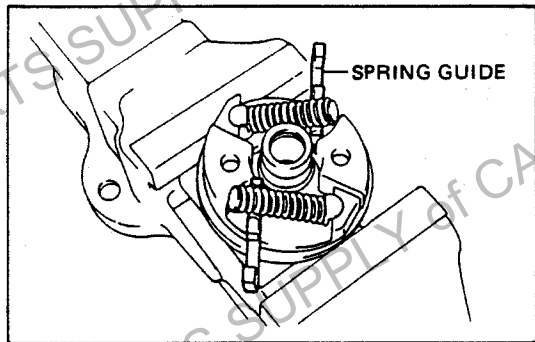

IMPORTANT POINT (S) – ASSEMBLY

SET THE TIMER SPRINGS.

Special Tool: Spring Guide (09512-1240)

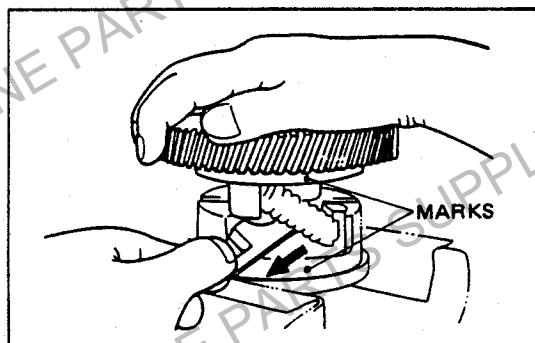

INSTALL THE TIMER FLANGE WITH DRIVE GEAR.

1. Align the marks on the drive gear and timer hub.
2. Hold the drive gear so that the springs will not fall out.

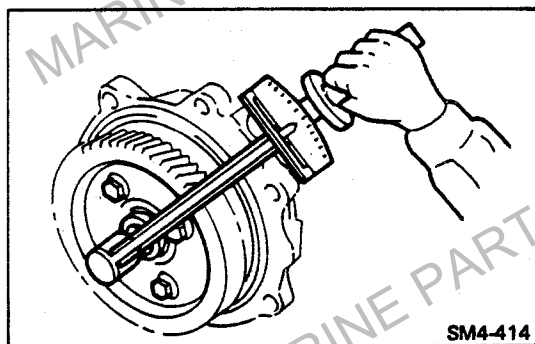

IMPORTANT POINT (S) – MOUNTING

INSTALL THE TIMER ASSEMBLY TO INJECTION PUMP.

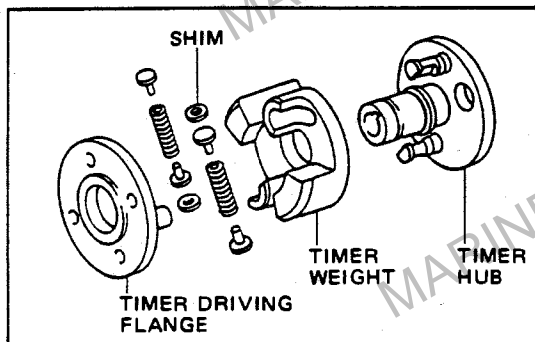

ADJUSTMENT OF THE TIMER.

INSPECT THE TIMER ADVANCE.

1. Set a stroboscope on a pump tester.
2. Check the timer advance.

Advance Angle: Refer to "CALIBRATION chart".

If angle is not within specification, adjust with proper shim.

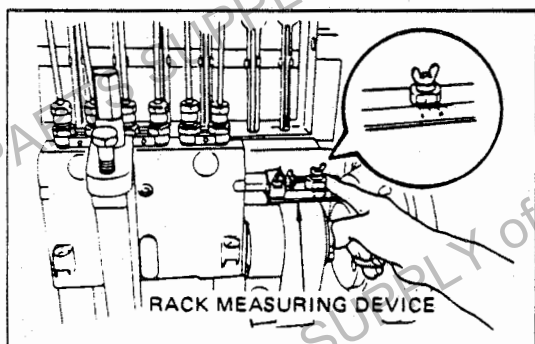
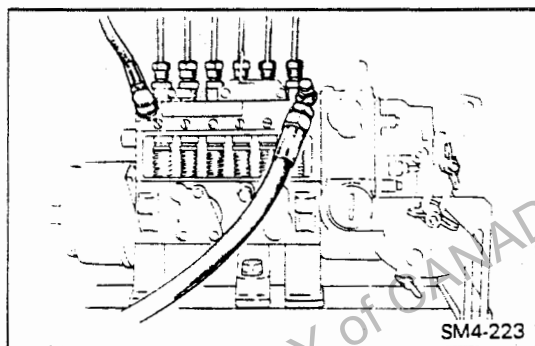

ADJUSTMENT

PREPARATION

1. Mount the injection pump correctly on the pump tester.
Remove the timer case in case of the SCZ type timer.
2. Attach a rack measuring device to the control rack and set to "0".
3. Install calibration nozzles and lines of the following specifications.
 - a) Nozzle
Nozzle type: 12SD12 (BOSCH Type)
Opening pressure: 175 kg/cm (2,489 lb.ft)
 - b) Line
Outside diameter: 6.0 mm (0.24 in)
Inner diameter: 2.0 mm (0.08 in)
Length: 600 mm (23.6 in)
4. Calibration oil
 - a) Calibration oil: SAE J967C
 - b) Oil temperature: 40–50°C (104–113°F)
5. Install the cover on the feed pump mounting surface and fill the pump camshaft chamber with engine oil.

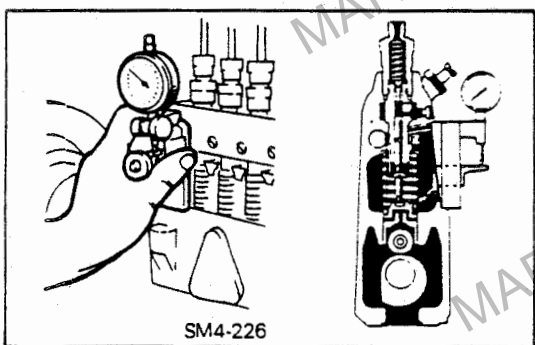
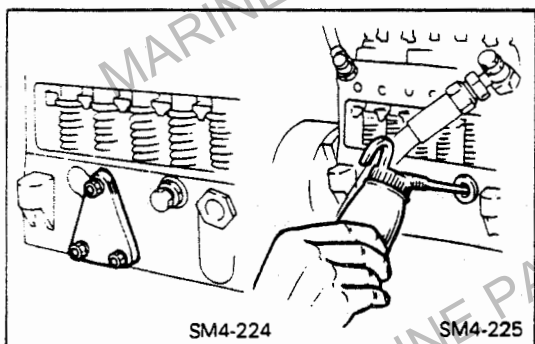

ADJUSTING THE INJECTION TIMING

1. Preparation of the pre-stroke.
 - a) Remove the plate cover.
 - b) Install a pre-stroke measuring instrument.
Bring the tappet of the first cylinder to its bottom dead center, and set the pointer tip on the tappet.

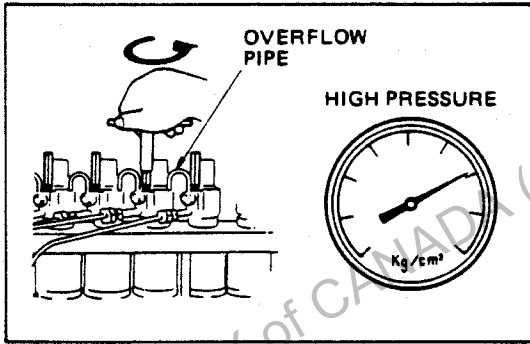

2. Measure the pre-stroke (No.1 plunger)
 - a) Set the control rack at full-load position.
 - b) Loosen the overflow screw of each nozzle holder.
 - c) Operate the high-pressure pump of the pump tester and let fuel run out of the overflow line.

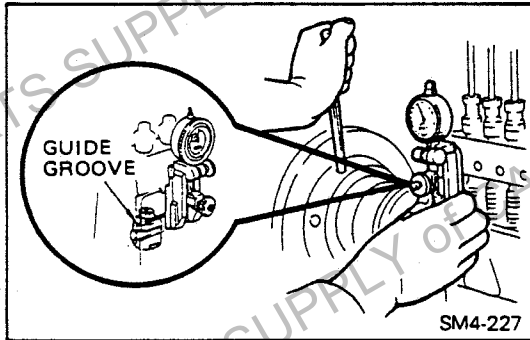

- d) Move the angle dial to set the first cylinder of the pump to bottom dead center and adjust the pre-stroke gauge to zero.

NOTE: Bottom dead center is the point at which the pointer of the dial gauge does not move even when the angle dial is rotated while fuel is flowing from the overflow line.

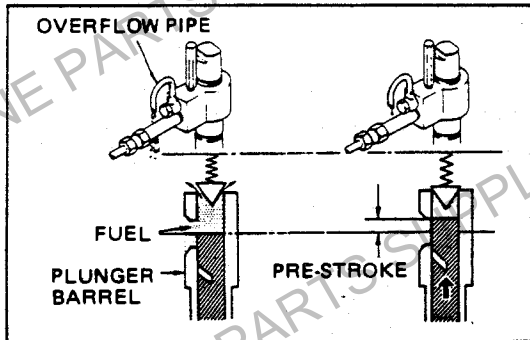

- e) Turn the camshaft clockwise with the angle dial and read the dial gauge when the fuel stops running out of the overflow line. This reading is the pre-stroke value of the pump.

Pre-stroke: Refer to "CALIBRATION chart"

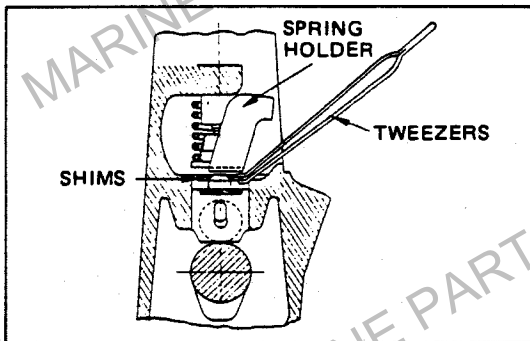

- f) If the pre-stroke value is not within specification, adjust by changing the tappet adjusting shim.

Special Tool: Spring Holder (95092-10070)

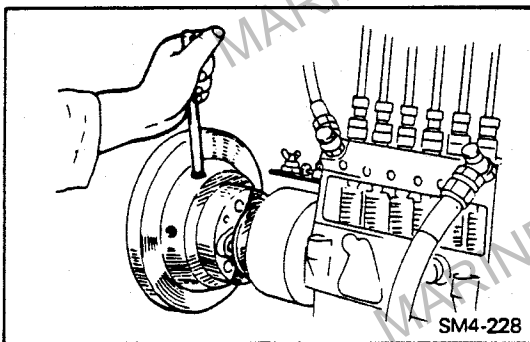

ADJUST THE INJECTION INTERVAL.

1. Using the No.1 cylinder injection starting point as a base, inspect and adjust the injection interval in the order of injection.

	6-cylinder	4-cylinder
Injection Interval:	59° 45' - 60° 15'	89° 45' - 90° 15'
Injection Order:	1-4-2-6-3-5	1-3-4-2

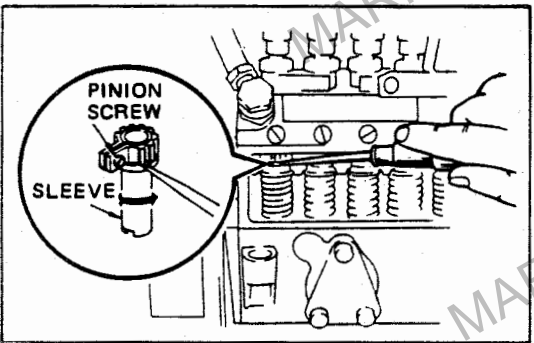
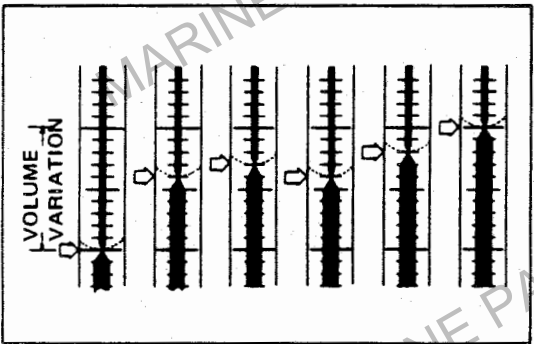
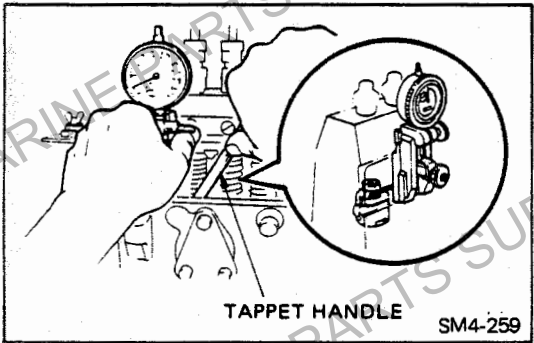
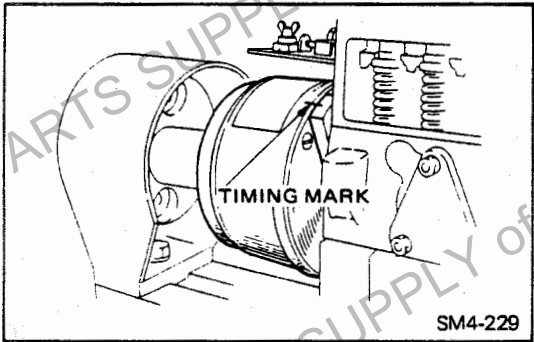
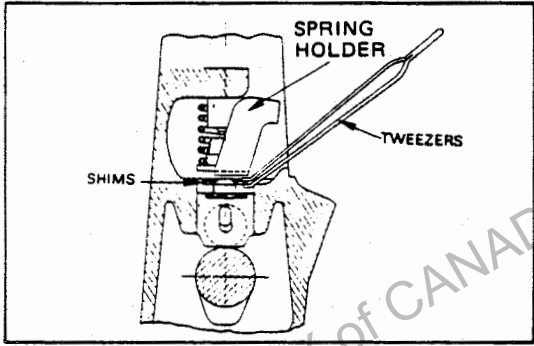

2. If the injection intervals are not within specification, adjust by using the same procedure as for pre-stroke adjustment.

3. Set the No.1 cylinder at the injection starting point, and check that the marks on the timer and the marks on the pump body are aligned.
If the timing marks are not aligned, make a new mark on the timer and erase the old mark.

CHECK THE TAPPET TOP CLEARANCE.

1. Set the No.1 cylinder at the injection starting point, then move the tappet with the handle.

Tappet Top Clearance: More than 0.2 mm (0.0079 in)
Special Tool: Tappet Handle (09512-1410)

2. Follow the above procedure to check the other cylinders (No.2 through No.6).

3. If the tappet clearance is less than 0.2 mm (0.0079 in), re-check the pre-stroke.

MEASURING AND ADJUSTING THE INJECTION VOLUME.

Measure the injection volume for each control rack position and pump revolution.

Injection Volume: Refer to "CALIBRATION chart."

To adjust the injection volume, loosen the pinion screw and insert the adjusting pin into the hole in the control sleeve, then move the sleeve slightly.

(K.P.)

CHAPTER GV

INJECTION PUMP GOVERNOR

(MODEL: RSV)

DESCRIPTION GV-2

GOVERNOR GV-3

SPECIAL TOOL GV-4



DESCRIPTION

[MODEL: RSV]

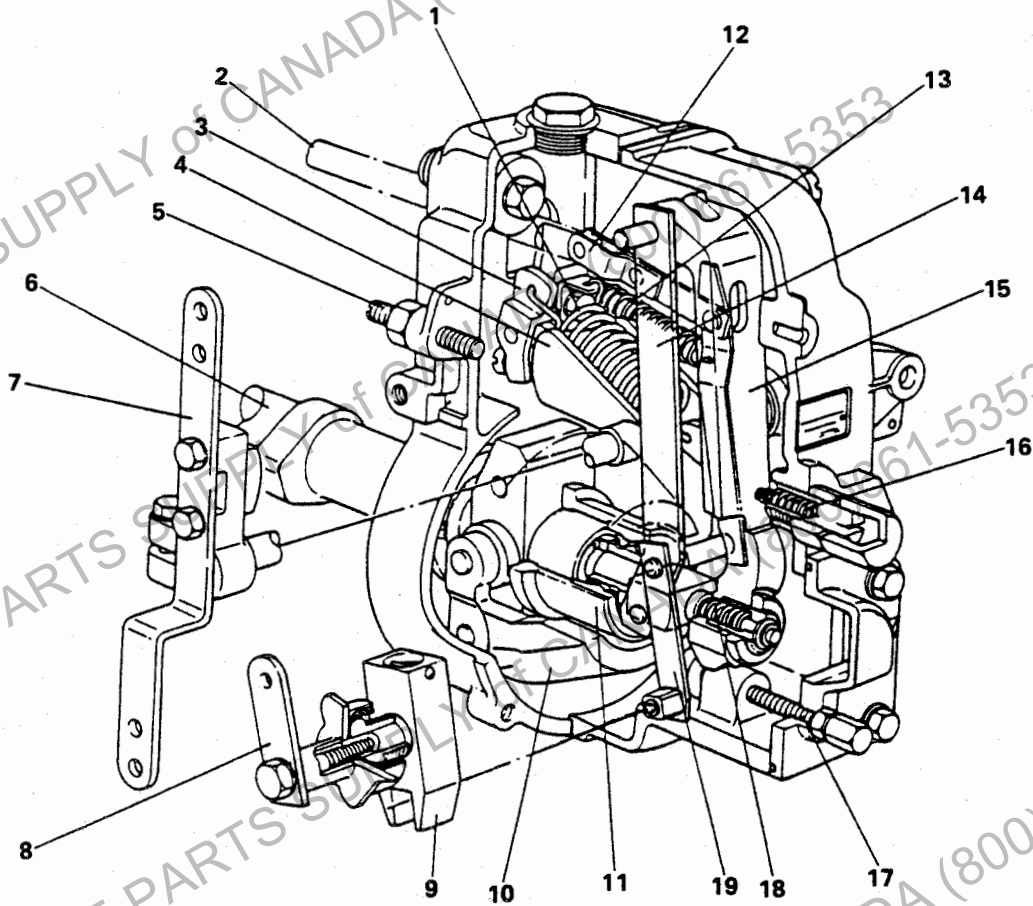

- | | |
|-------------------------------|----------------------------|
| 1. Governor spring | 11. Sleeve |
| 2. Control rod | 12. Link |
| 3. Knuckle | 13. Start spring |
| 4. Swivel lever | 14. Guide lever |
| 5. Maximum speed stopper bolt | 15. Tension lever |
| 6. Camshaft | 16. Idle sub spring |
| 7. Control lever | 17. Full load stopper bolt |
| 8. Stop lever | 18. Idle spring |
| 9. Supporting lever | 19. Floating lever |
| 10. Flyweight | |

GOVERNOR

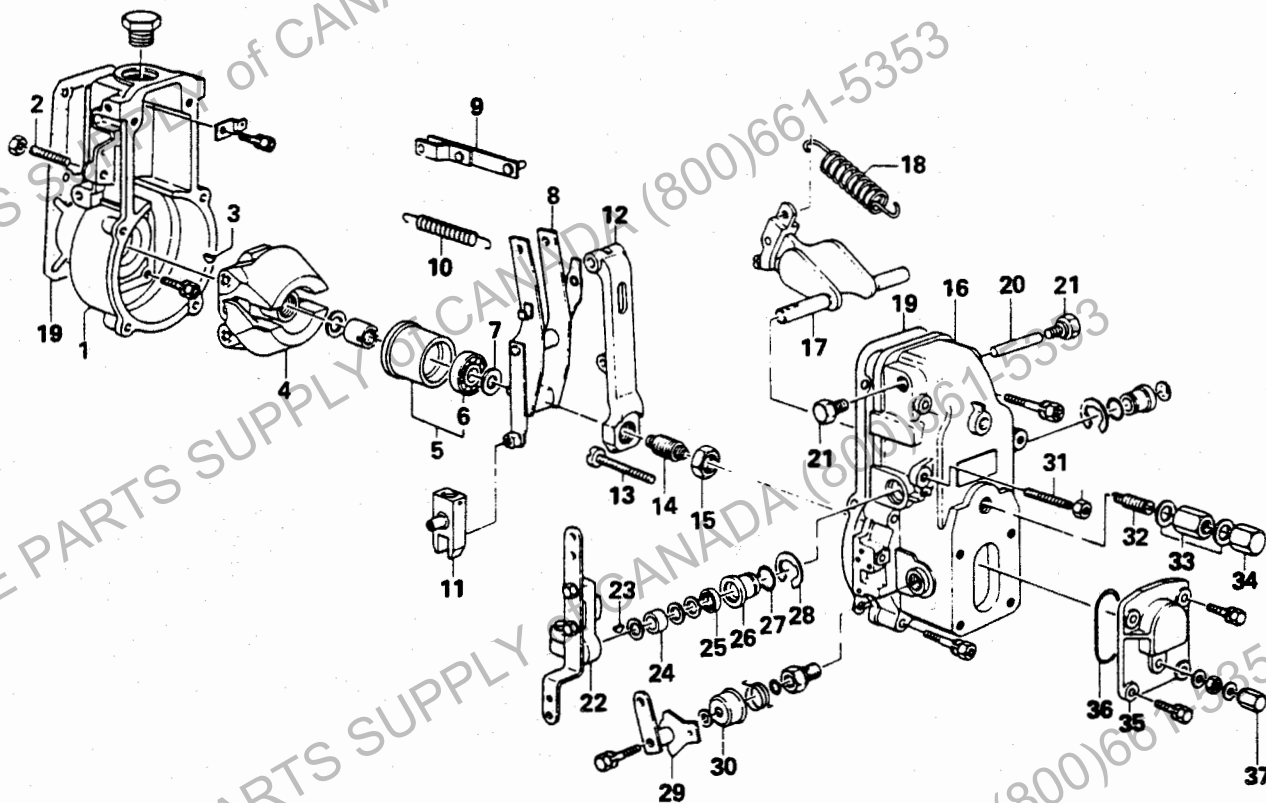

- | | | |
|-----------------------|---------------------|-----------------------|
| 1. Governor housing | 14. Idle spring | 27. O-ring |
| 2. Stopper bolt | 15. Lock nut | 28. Snap ring |
| 3. Woodruff key | 16. Governor cover | 29. Stop lever |
| 4. Flyweight | 17. Swivel lever | 30. Cap |
| 5. Sleeve | 18. Governor spring | 31. Idle stopper bolt |
| 6. Bearing | 19. Gasket | 32. Idle sub spring |
| 7. Shim | 20. Pin | 33. Nut |
| 8. Guide lever assy | 21. Plug | 34. Cap nut |
| 9. Link | 22. Control lever | 35. Closing cover |
| 10. Start spring | 23. Woodruff key | 36. O-ring |
| 11. Supporting lever | 24. Collar | 37. Cap nut |
| 12. Tension lever | 25. Oil seal | |
| 13. Full load stopper | 26. Bush | |

SPECIAL TOOL

Prior to starting an injection pump governor overhaul, it is necessary to have these special tools.

FLYWEIGHT EXTRACTOR

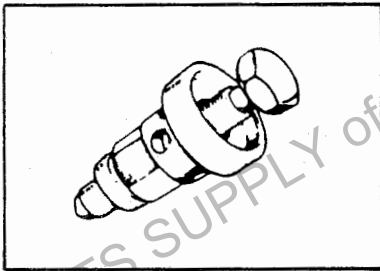

09511-1900

ROUND NUT WRENCH

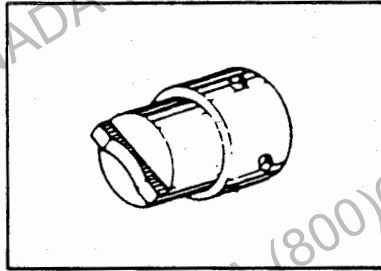

09511-1500

IMPORTANT POINT (S) – DISASSEMBLY

WARNING

- Breaking of the lead seals or crimp caps by any other other than HINO or pump manufacture authorized service stations to make these adjustment will void the warranty.
- If fuel pump or governor difficulties are suspected, consult only HINO or pump manufacture authorized service stations, where the problem can be corrected and the injection pump lead seals and crimp caps can be reinstalled as required.

DISASSEMBLY THE GOVERNOR COVER FROM PUMP BODY.

1. Disconnect the shackle from the control rack.

NOTE: When remove the governor cover fitting bolt, hold the governor cover.

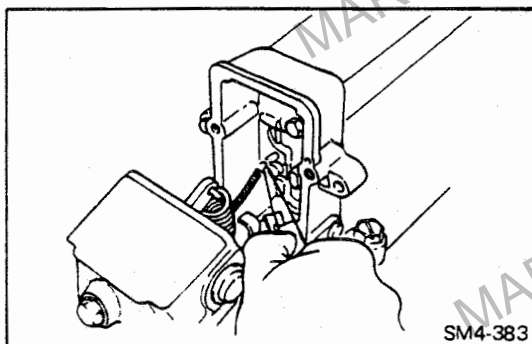
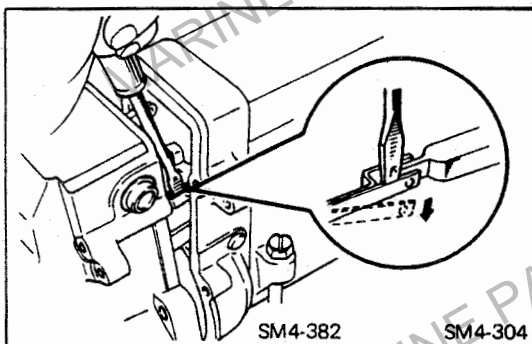

2. Disconnect the start spring.

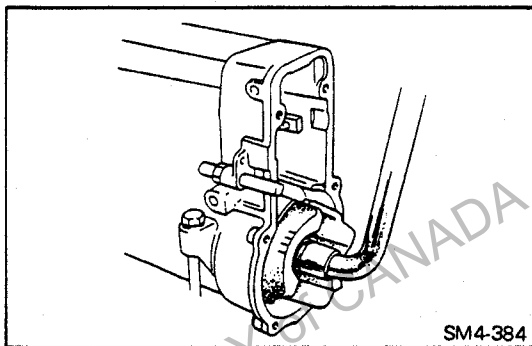

SM4-384

REMOVE THE FLYWEIGHT ROUND NUT.

NOTE: Use the holding spanner to keep the camshaft from rotating.

Special Tools: Round Nut Wrench (09511-1500)

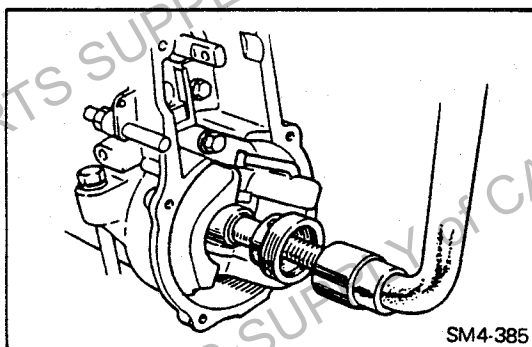

SM4-385

REMOVE THE FLYWEIGHT, USING THE FLYWEIGHT EXTRACTOR.

Special Tool: Flyweight Extractor (09511-1900)

IMPORTANT POINT (S) – Assembly**WARNING**

- Wash all parts with clean diesel fuel before installing them, and any defective or damaged parts must be replaced.
- Do not allow dust or other foreign matter to enter the pump during assembly.
- Apply grease to O-rings and oil seals before installing them.
- Assemble the parts in correct order and to correct tightening torque, assembled dimensions etc.
- Assembly takes place in the reverse order of disassembly.

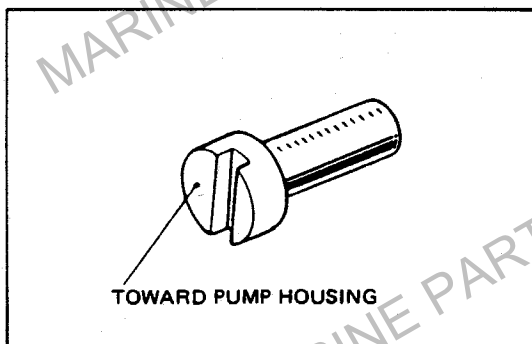
**INSTALL THE ADJUSTING LEVER**

1. Install the shaft of the adjusting lever so that wide side of the shaft head surface is toward the pump body.

NOTE: Installing in reverse may cause the floating lever to contact the speed control spring, resulting in operational malfunction.

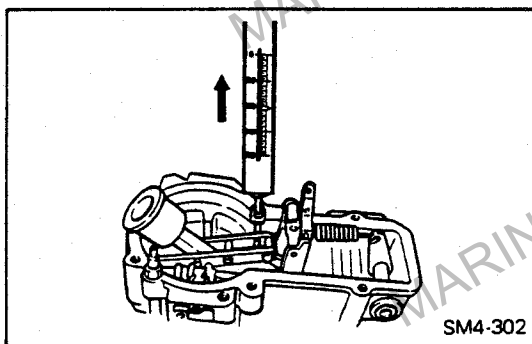

SM4-302

CHECK THE GOVERNOR LINKAGE FOR SMOOTH OPERATION.

Hook under the guide lever, and pull upwards, using a spring balance.

Starting force: 140–180 g (4.9–6.3 oz)

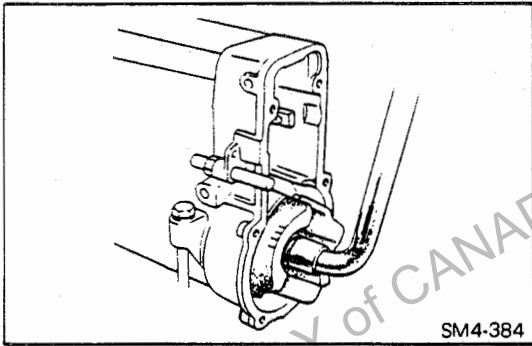
**INSTALL THE FLYWEIGHT TO PUMP CAMSHAFT.**

Using a special tools, tighten the round nut.

Special Tools: Round Nut Wrench (09511-1500)

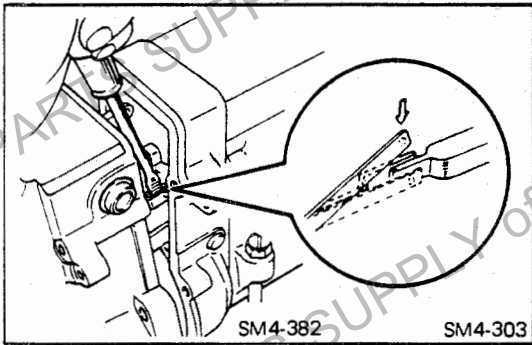
**INSTALL THE GOVERNOR HOUSING TO PUMP BODY.**

1. Connect the start spring.
2. Connect the shackle to control rack.

**ADJUSTMENT OF THE GOVERNOR
[MODEL; RSV]****1. PREPARATION**

1. Connect the rack measuring device to the control rack and set to "0".
2. Connect the fuel line.
3. Refill the camshaft chamber with engine oil.
4. Install the angle gauge on the adjusting lever.

2. STEPS IN GOVERNOR ADJUSTMENT.

Perform governor testing and adjustment in the following sequence (For values of N. and R Refer to "CALIBRATION chart"):

1. Adjustment of maximum speed control.
2. Adjustment of speed droop.
3. Adjustment of idling speed control.

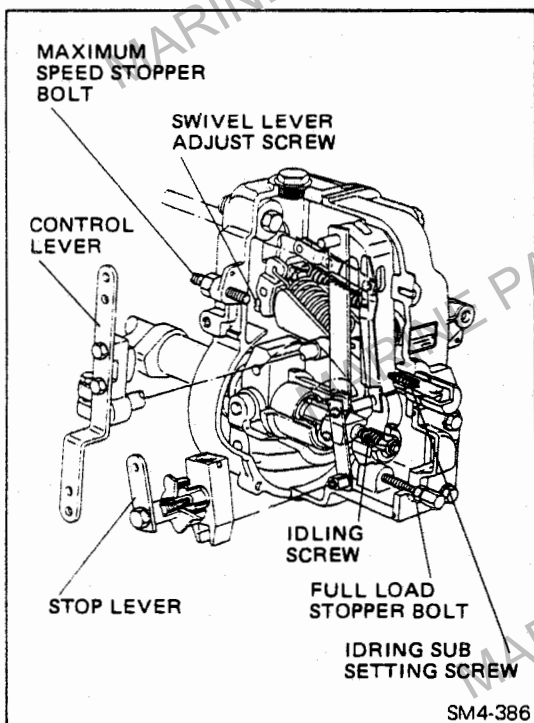

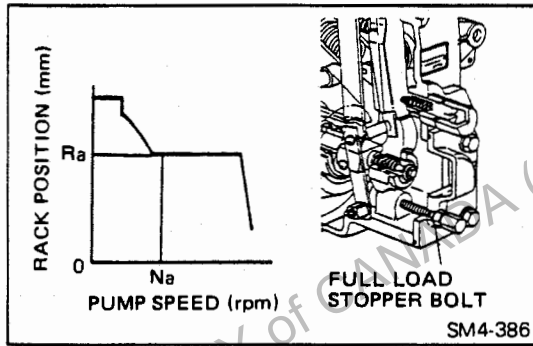

1. Adjustment of maximum speed control

NOTE: The control lever should be full load position.

a) Adjust the full load stopper bolt.

At a pump speed of N_a rpm, adjust the rack position to R_a mm with the full load stopper bolt.

b) Adjust the maximum speed stopper bolt.

At a pump speed of N_b rpm, adjust the rack position to R_b mm with maximum speed stopper bolt.

NOTE: The control rack should start to be pulled.

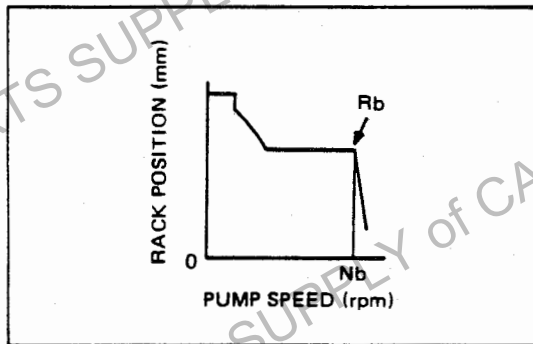

2. Adjust of speed droop.

At a pump speed of N_c rpm, adjust rack position to R_c mm with swivel lever adjusting screw.

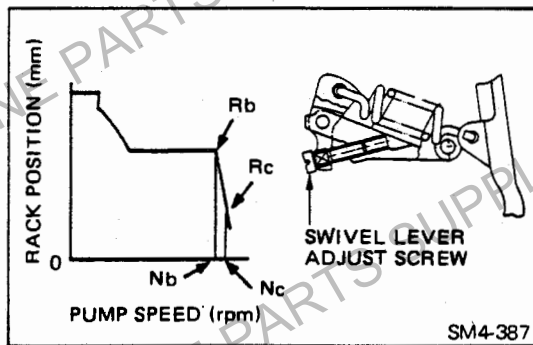

3. Adjusting of idling speed control

a) At a pump speed of N_a rpm, adjust the rack position to R_d mm with idling screw.

NOTE: The control lever angle, refer to CALIBRATION chart.

b) At a pump speed of N_e rpm, adjust the rack position to R_e mm with idling sub setting screw.

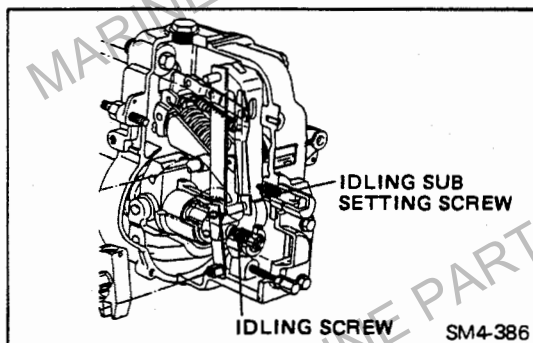

GOVERNOR EXTERNAL LEAD SEALS AND CRIMP CAPS.

NOTE: All adjusting devices on the fuel injection pump governor, are wired and lead sealed as a protection for the customer. This is to prevent unauthorized readjustment which may cause engine malfunction and/or engine failure. Periodically check to insure that these seals are not broken as this will void the warranty.

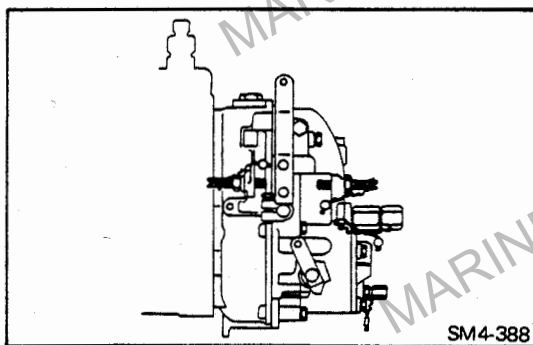

(K.P.)

**Marine
Parts
Supply
of Canada**

1520 Stewart Ave
Nanaimo, B.C.
V9S 4E1
ph (800) 661-5353
fax (250) 754-9471

FEED PUMP

FP/KE-TYPE

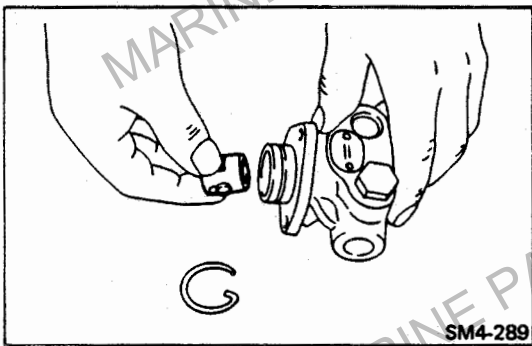
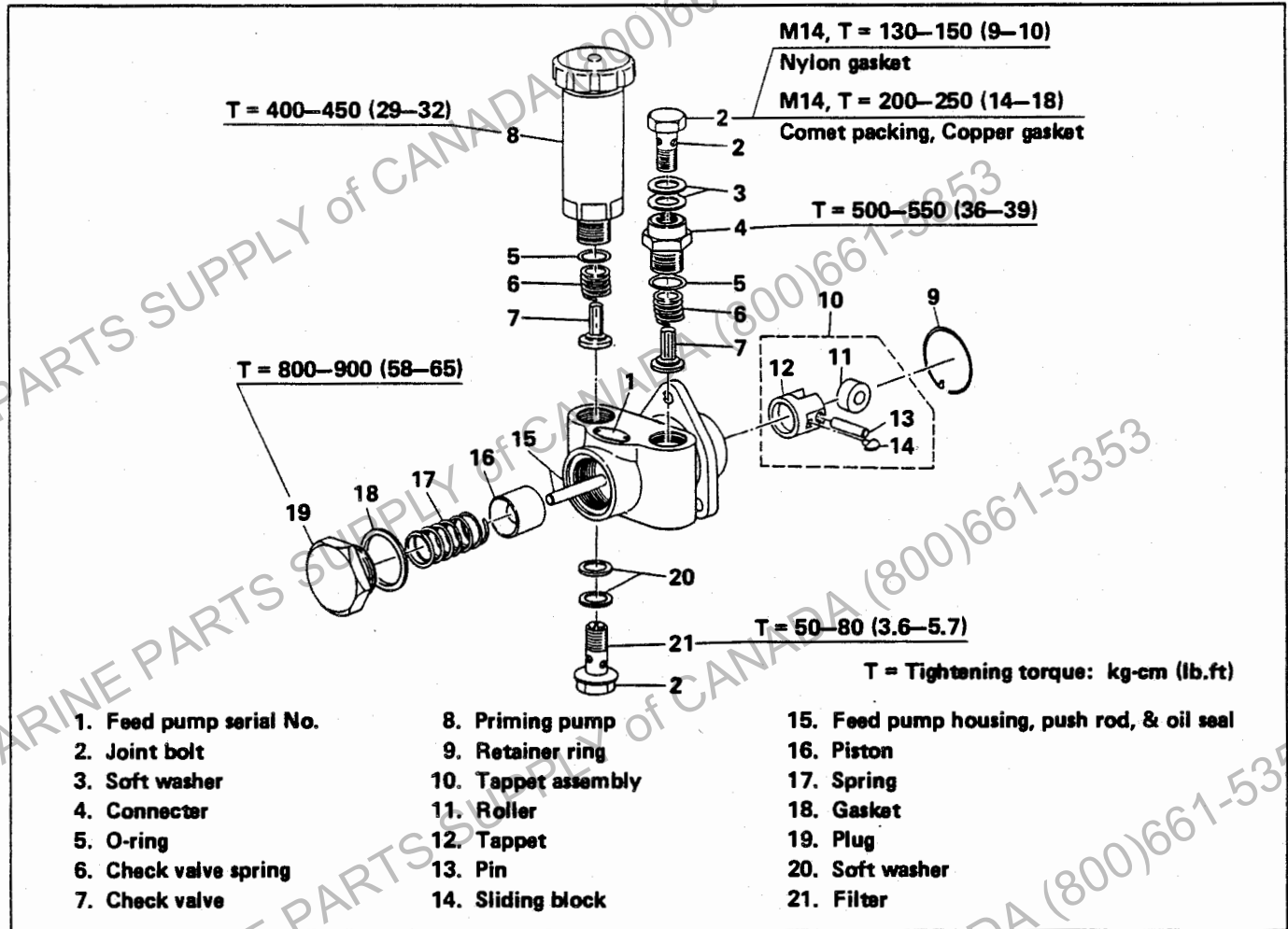

REMOVE THE TAPPET

Remove the snap ring and pull out the tappet.

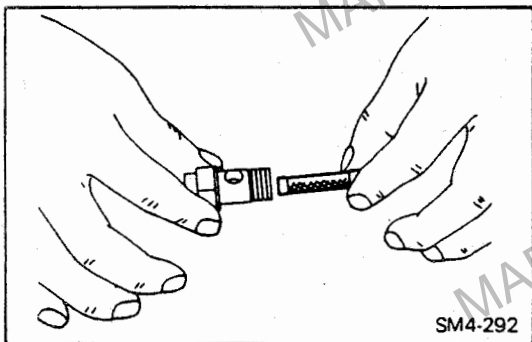

REMOVE THE FILTER FROM INLET PIPE JOINT.

Clean the filter with clean diesel fuel.

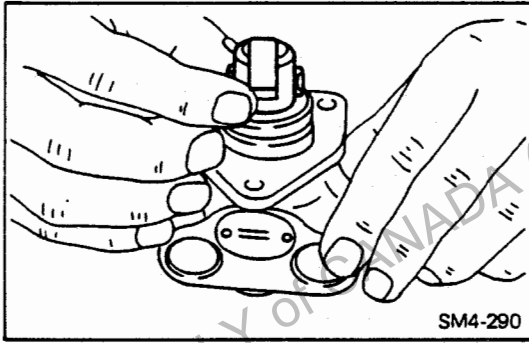

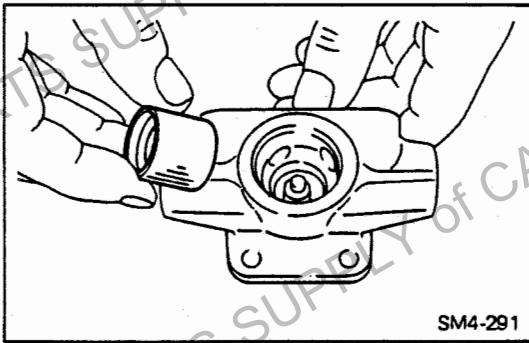

IMPORTANT POINT (S) – ASSEMBLY
INSTALL THE TAPPET.
INSTALL THE SNAPRING.



INSTALL THE PISTON.

Insert the piston and spring in the housing and screw on the chamber plug with a new gasket.

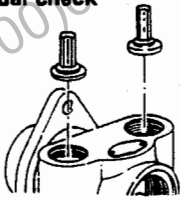
INSPECTION AND REPAIR

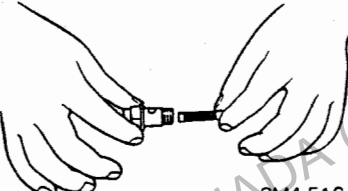
Inspection Item	Standard	Limit	Remedy	Inspection Procedure
Valve Seat. Wear, Damage	—	—	Replace, if necessary.	Visual check  SM4-517
Piston, Cylinder and Oil Seal. Wear, Damage	—	—	Replace, if necessary.	Visual check  SM4-518
Filter, Clogged	—	—	Clean	Visual check  SM4-516

CHAPTER

GENERATOR

(12V, 50A)

DATA AND SPECIFICATIONS	GE-2
DESCRIPTION	GE-2
TROUBLESHOOTING	GE-3
GENERATOR	GE-4



DATA AND SPECIFICATIONS

MODEL	27040-1300
GENERATOR	
Type	Alternator
Rated voltage	12V
Rated output	50A
Operating output and speed	13.5V, 50A at 4,000 rpm (at cold)
Rotating direction	Clockwise (Seen from pulley side)
REGULATOR	
Type	I.C. Regulator

DESCRIPTION

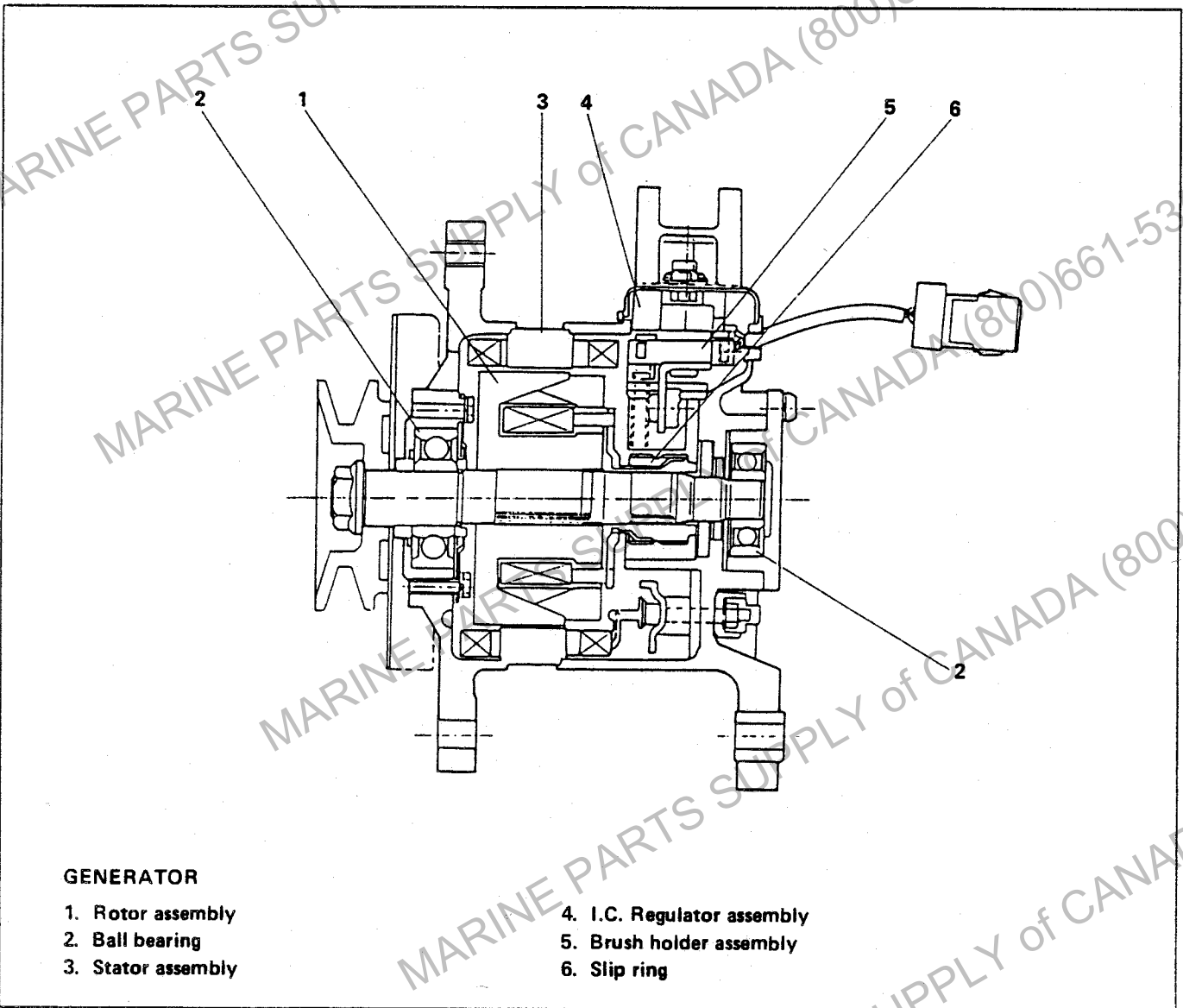

GENERATOR

- 1. Rotor assembly
- 2. Ball bearing
- 3. Stator assembly
- 4. I.C. Regulator assembly
- 5. Brush holder assembly
- 6. Slip ring

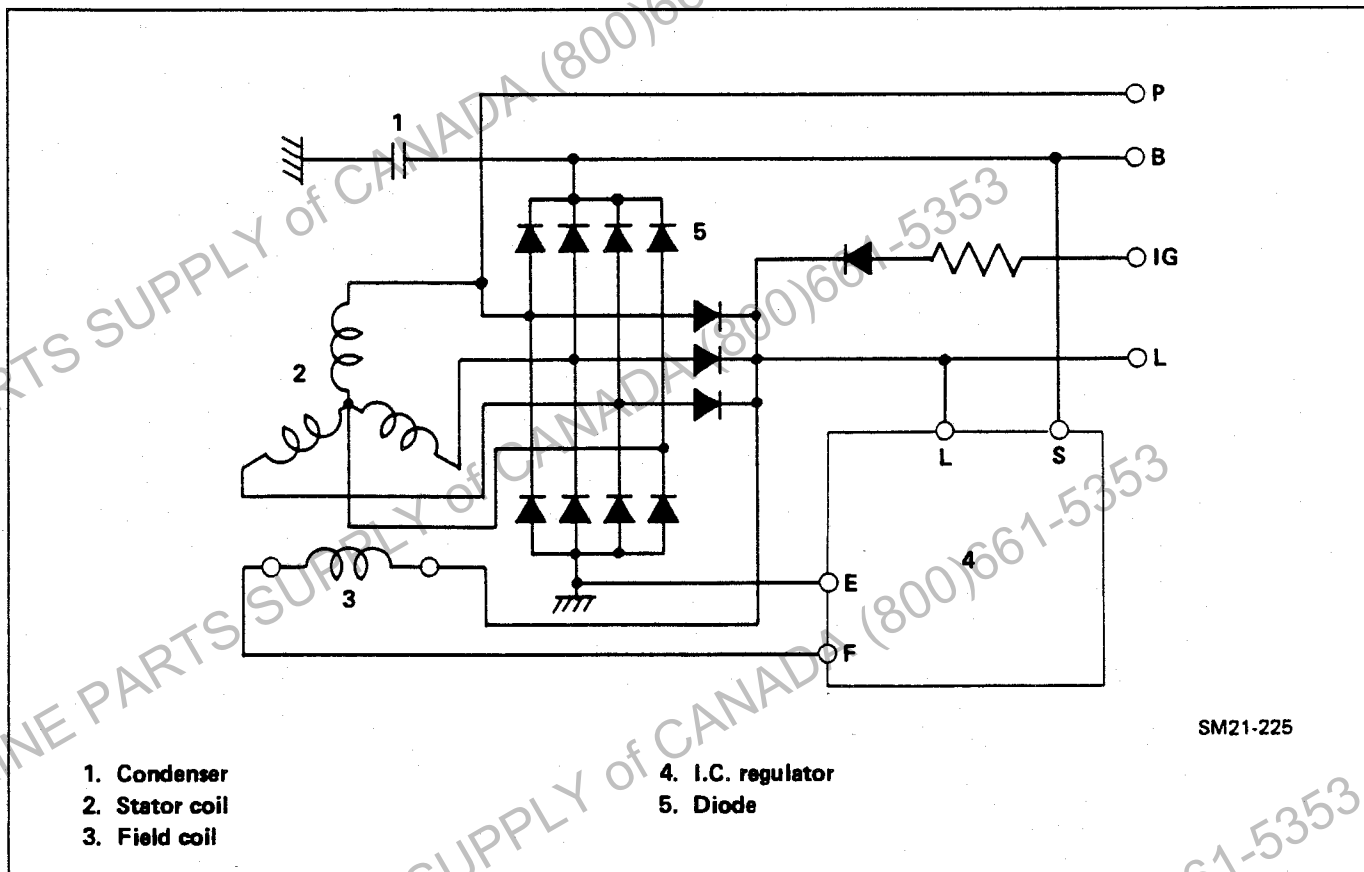

TROUBLESHOOTING

Symptom	Possible cause	Remedy/Prevention
Charging warning lamp does not light with starter switch ON and engine off	Fuse blown	Determine cause and replace fuse
	Lamp burned out	Replace lamp
	Wiring connection loose	Tighten loose connections
	Charge lamp relay faulty	Check relay
	IC regulator faulty	Replace IC regulator
Charge warning lamp does not go out with engine running (Battery requires frequent recharging)	Drive belt loose or worn	Adjust or replace drive belt
	Battery cable loose, corroded or worn	Repair or replace cables
	Fuse blown	Determine cause and replace fuse
	Fusible link blown	Replace fusible link
	Charge lamp relay, IC regulator or generator faulty	Check charging system
	Wiring faulty	Repair wiring

GENERATOR

1824B
I-NO. 22

T = 800-1,000
(58-72)

T = 30-50
(2.2-3.6)

T = 70-100 (5.1-7.2)

T = 70-90 (5.1-6.5)

T = Tightening torque: kg-cm (lb-ft)

- 1. Pulley
- 2. Fan
- 3. Drive and frame
- 4. Collar
- 5. Felt washer
- 6. Felt cover
- 7. Ball bearing
- 8. Cover
- 9. Retainer ring

- 10. Rear bearing cover
- 11. Stator assembly
- 12. Rotor assembly
- 13. Rectifier
- 14. Insulator
- 15. Rear end frame
- 16. Bush
- 17. Through bolt
- 18. Cover

- 19. Ball bearing
- 20. Condenser
- 21. Brush
- 22. Spring
- 23. Brush holder
- 24. I.C. Regulator assembly
- 25. Cover
- 26. Lead wire

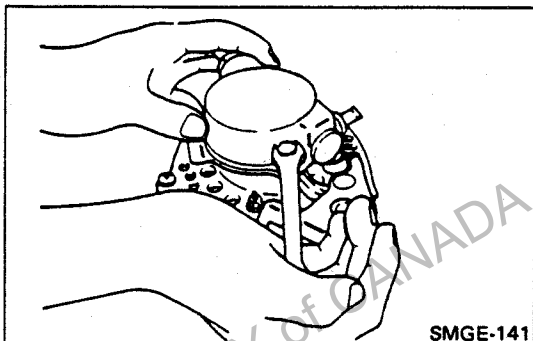

SMGE-141

IMPORTANT POINT(S) – DISASSEMBLY**REMOVE THE REAR END COVER.**

Remove the rear end cover with bearings.

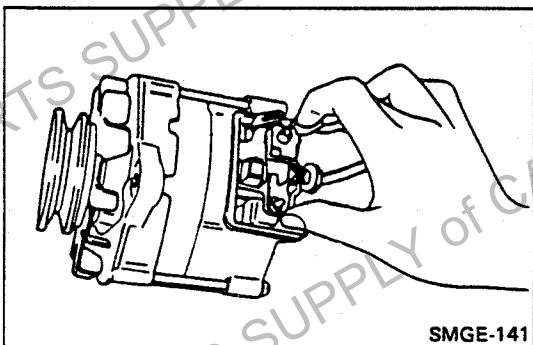

SMGE-141

REMOVE THE I.C. REGULATOR AND BRUSH HOLDER.

1. Remove the bolts and disconnect the wires.
2. Remove the I.C. regulator and brush holder assembly.
3. Remove the through bolts and separate the front cover from the stator.

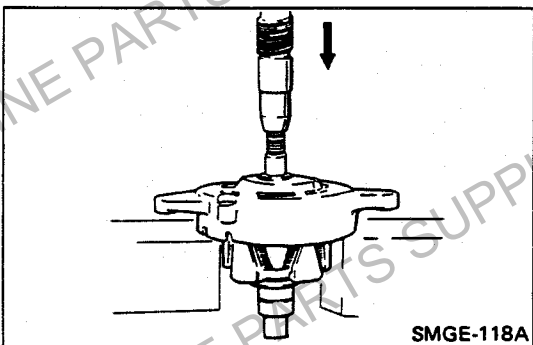

SMGE-118A

REMOVE THE ROTOR.

Using a press, remove the rotor and collar.

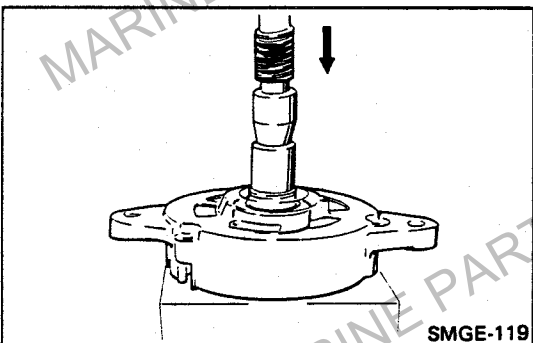

SMGE-119

REMOVE THE FRONT BALL BEARING.

1. Remove the retainer plate.
2. Using a press, remove the front ball bearing.
3. Remove the plate and felt.

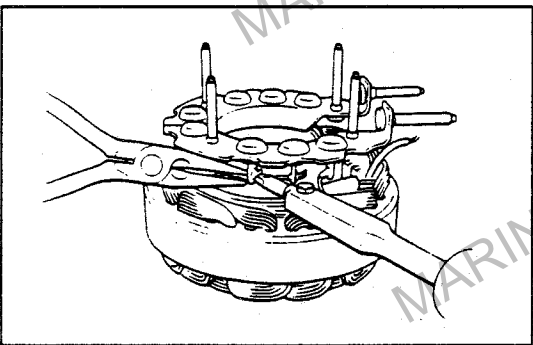
**REMOVE THE STATOR AND RECTIFIER.**

1. Remove the nuts, insulator and stator terminal with the rectifier.
2. Unsolder the stator lead from the rectifier.

NOTE: Hold the rectifier terminal with long nose pliers.

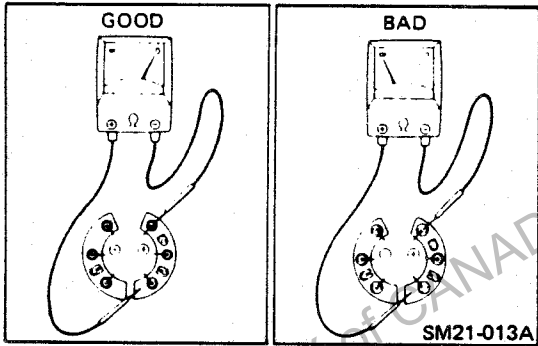

IMPORTANT POINT (S) – TESTING RECTIFIER.

Test the each positive side rectifier condition. Connect the circuit tester \oplus lead to the rectifier holder and the \ominus lead to the rectifier terminal.

\oplus lead to the rectifier terminal and \ominus lead to the rectifier holder.

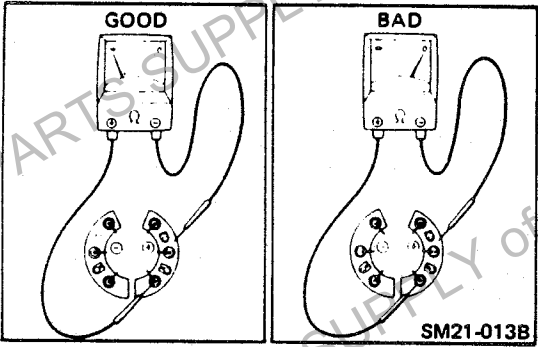

Test the each negative rectifier condition. Connect the circuit tester \oplus lead to the rectifier terminal and the \ominus lead to the rectifier holder.

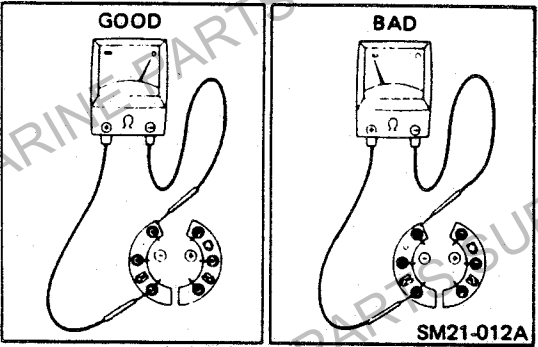

\oplus lead to the rectifier holder and \ominus lead to the rectifier terminal.

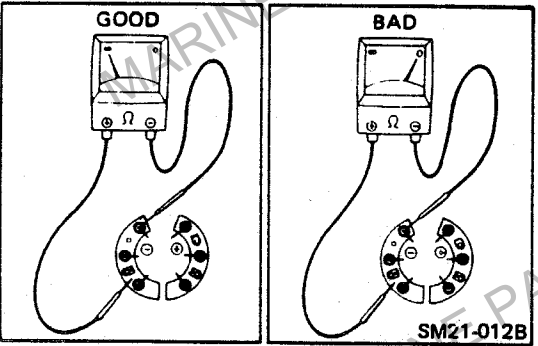

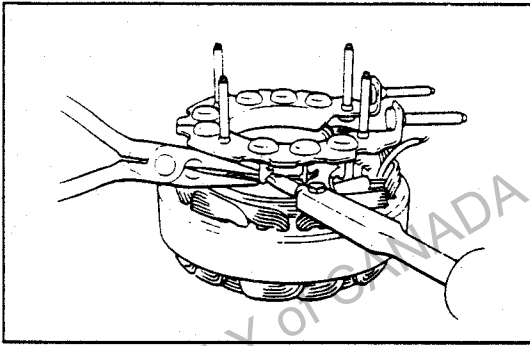
**IMPORTANT POINT(S) – ASSEMBLY****INSTALL THE STATOR AND RECTIFIER.**

1. Install the stator lead to the rectifier.

NOTE: Hold the rectifier terminal with long nose pliers.

2. Install the nuts, terminal insulator and stator with rectifier.

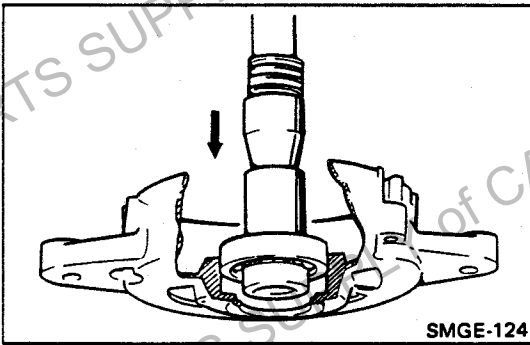
**INSTALL THE FRONT BALL BEARING.**

1. Install the felt and felt cover.
2. Using a press, install the front ball bearing.
3. Install the retainer plate.

NOTE: Apply the bearing grease to bearing and oil seal lip.

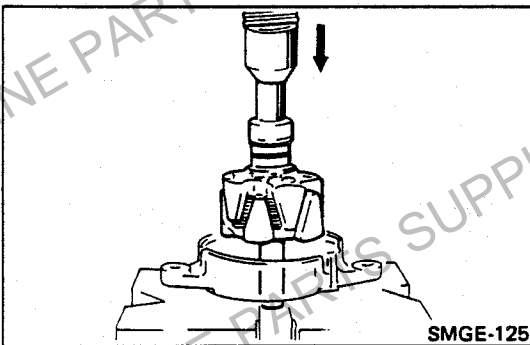
**INSTALL THE ROTOR.**

Using a press, install the rotor.

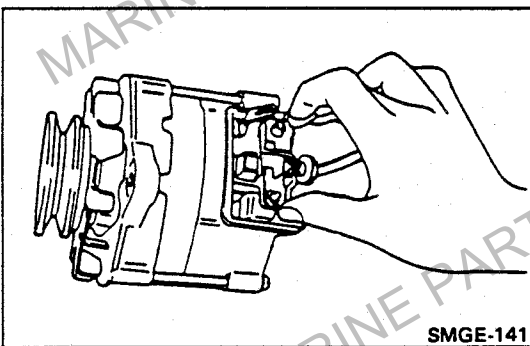
**INSTALL THE I.C. REGULATOR AND BRUSH HOLDER.**

1. Connect the front cover to the stator and tighten the through bolts.
2. Install the I.C. regulator and brush holder assembly.
3. Install the bolts and connect the wires.

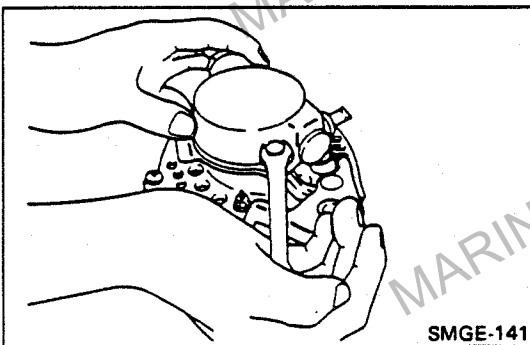
**INSTALL THE REAR COVER.**

Install the rear cover with bearings.

PERFORMANCE TEST

NOTE: ○ Note the battery polarity carefully so as not to make reverse connections.

If the connections are reversed, the diodes will short the circuit and allow large current to flow through and damage the diodes and IC regulator as well as turn up the wiring harness.

- Use care not to make wrong connections of terminals.
- When charging the battery with a quick charge. Disconnect the battery terminals.
- Do not perform tests with high voltage insulation resistance tester.
- When in operation, never disconnect the battery.

GENERATOR PERFORMANCE TEST.

1. Turn on switch SW₁ and off SW₂ to increase the rotation of the alternator slowly.

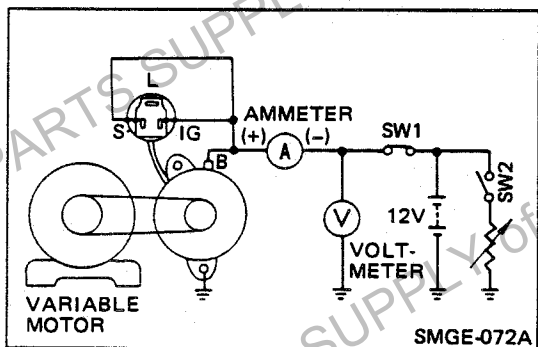

2. When voltage reaches 13.5V, turn on switch SW₂ regulate load resistance. Increase the rotation of the rotor keeping voltage at 13.5V.

MAX Generator Speed: Less than 4,000 rpm at 13.5V, 50A

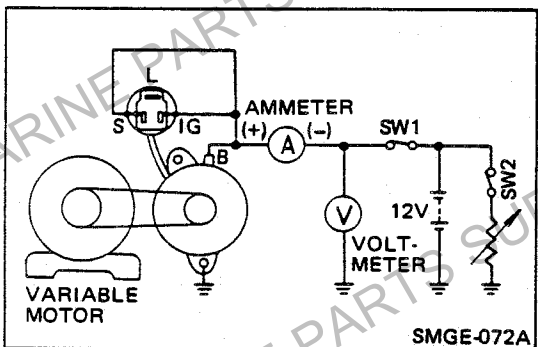

VOLTAGE REGULATION TEST.

Turn on switch SW₁ and off SW₂ to increase the rotation of rotor to _____ rpm.

Standard Voltage: 14.2–14.8V

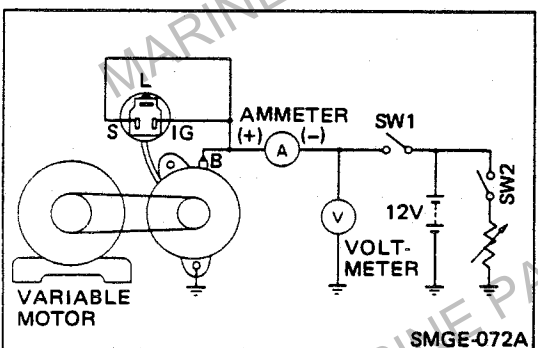

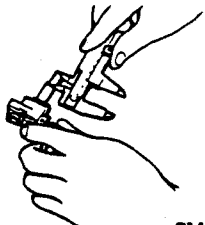
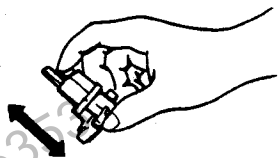
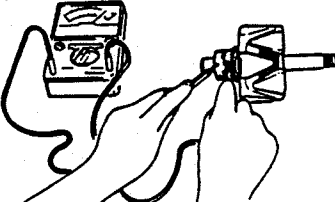
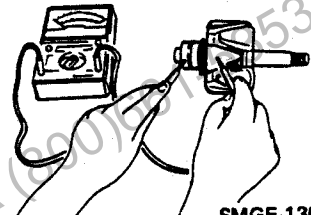
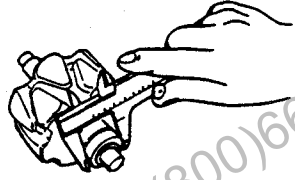
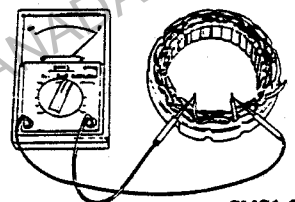
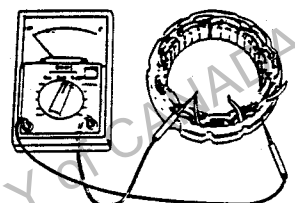

INSPECTION AND REPAIR

Unit: mm (in)

Inspection Item	Standard	Limit	Remedy	Inspection Procedure
Brush length	20.0 (0.787)	5.5 (0.217)	Replace	 <p>SMGE-127</p>
Function of the brush holder	-	-	Replace, if necessary.	<p>Visual check</p>  <p>SMGE-128</p>
Checking of the rotor coil.	About 2.9 Ω	-	Replace.	 <p>SMGE-129A</p>
Insulation between the slip ring and the core.	-	-	If continuity replace the rotor.	 <p>SMGE-130A</p>
Diameter of the slip ring.	32.5 (1.280)	32.1 (1.264)	Replace.	 <p>SMGE-131A</p>
Checking of the stator coil	-	-	If not continuity, replace the stator coil.	 <p>SM21-037</p>
Insulation of the stator coil.	-	-	If not continuity, replace the stator coil.	 <p>SM21-038</p>

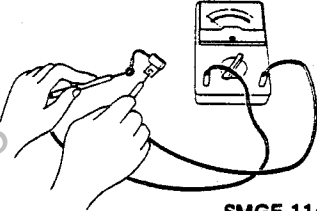
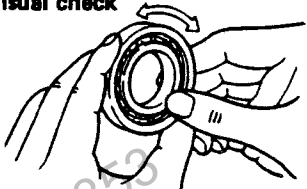
Unit: mm (in)

Inspection Item	Standard	Limit	Remedy	Inspection Procedure
Condenser capacity.	0.5 μ F	—	Replace	 <p>SMGE-114</p>
Wear or damage of the bearings.	—	—	Replace, if necessary.	<p>Visual check</p>  <p>SMGE-083</p>
Wear or damage of the felt.	—	—	Replace, if necessary.	<p>Visual check</p> 

(K.P.)

CHAPTER ST

STARTER

(12V, 2.5 KW)

DATA AND SPECIFICATIONS	ST-2
DESCRIPTION	ST-2
TROUBLESHOOTING	ST-3
STARTER	ST-5



DATA AND SPECIFICATIONS

Model No.	28100-1561
Starter	
Type	Reduction gear type
Output	12V, 2.5 KW
Number of teeth of pinion	11
Module	3
Rotation	Clockwise, viewed from pinion side

DESCRIPTION

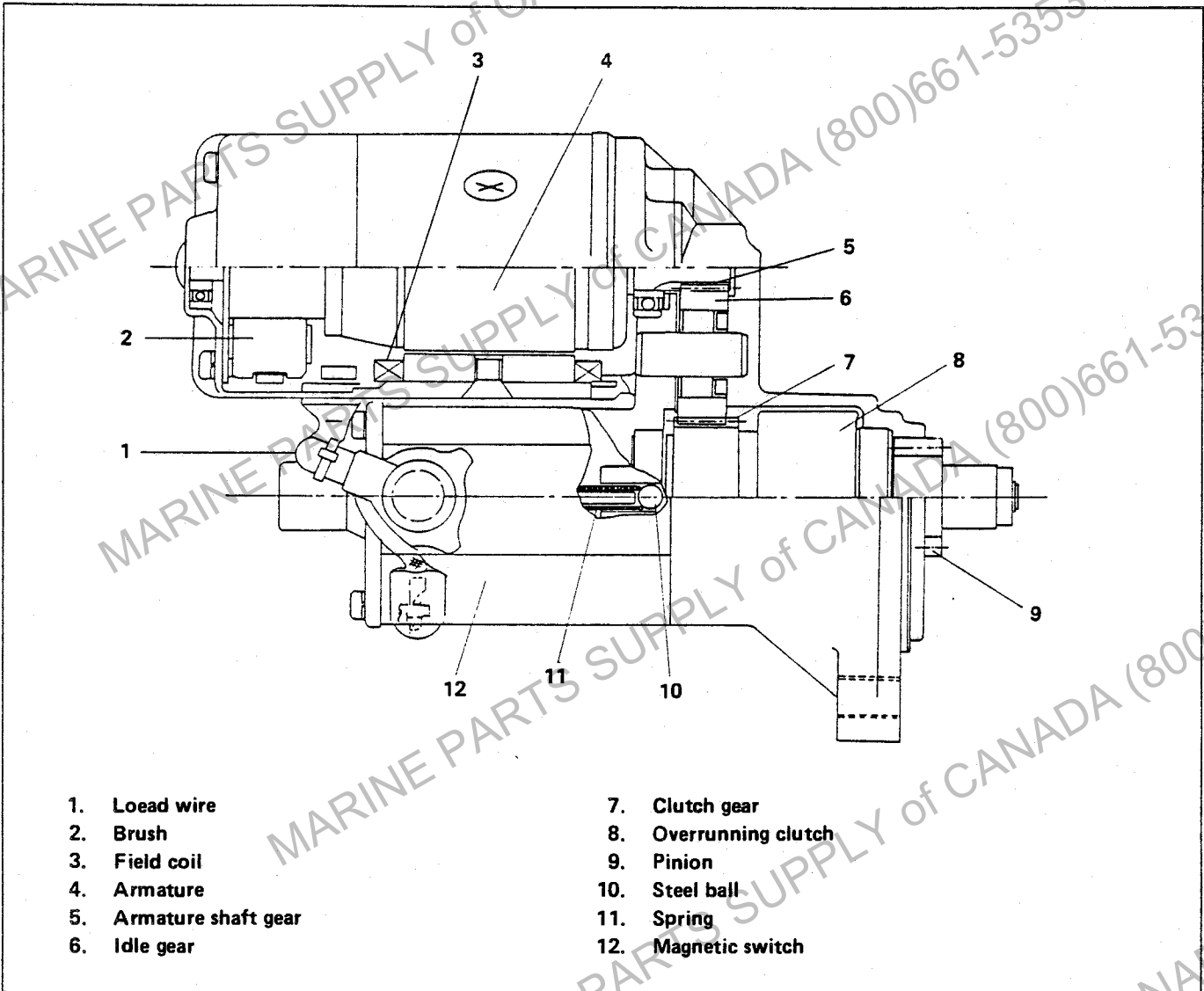

- | | |
|------------------------|-----------------------|
| 1. Load wire | 7. Clutch gear |
| 2. Brush | 8. Overrunning clutch |
| 3. Field coil | 9. Pinion |
| 4. Armature | 10. Steel ball |
| 5. Armature shaft gear | 11. Spring |
| 6. Idle gear | 12. Magnetic switch |

TROUBLESHOOTING

Symptom

Possible cause

Remedy/Prevention

Engine does not crank, or cranks slowly.

Key switch

- Poor contact. Polish or replace contacts

Battery

- Discharged battery Charge
- Short circuited between electrodes Replace battery
- Poor contact at battery terminal Plish or retighten

Engine oil

- Improper viscosity oil Change oil

Magnetic switch

- Poor contact caused by burnt contact plate Polish or replace contact plate
- Contact plate worn out. Repair
- Hold-in coil disconnected Replace field coil (Overrunning clutch moves back and forth)
- Pull-in coil disconnected or short circuited Replace

Starter relay

- Defective or poor contact Repair or replace

Starter

- Brush worn out. Replace
- Commutator burnt out Correct on lathe
- Commutator worn out Correct by undercutting
- Field winding shorted or grounded Rewind or replace
- Armature winding shorted or grounded Replace armature
- Insufficient brush spring tension Replace brush spring
- Poor contact between magnetic switch and field windings Repair
- Armature contacts pole core because of worn bearing bush or bent armature shaft Replace bearing brush or armature
- Overrunning clutch malfunction Replace

Engine does not crank while starter is running in good condition.

Overrunning clutch

- Overrunning clutch malfunction Replace
- Pinion teeth worn out Replace
- Poor sliding of spline teeth Remove foreign materials, dirt, or replace



Symptom

Possible cause

Remedy/Prevention

Starter does not stop running.

Key switch

- Contacts keep closing Replace
- Key switch sticks Replace
- Overrunning clutch sticks to armature Repair or replace overrunning clutch or armature

Starter relay

- Contacts keep closing Repair or replace

MARINE PARTS SUPPLY of CANADA (800)661-5353



STARTER

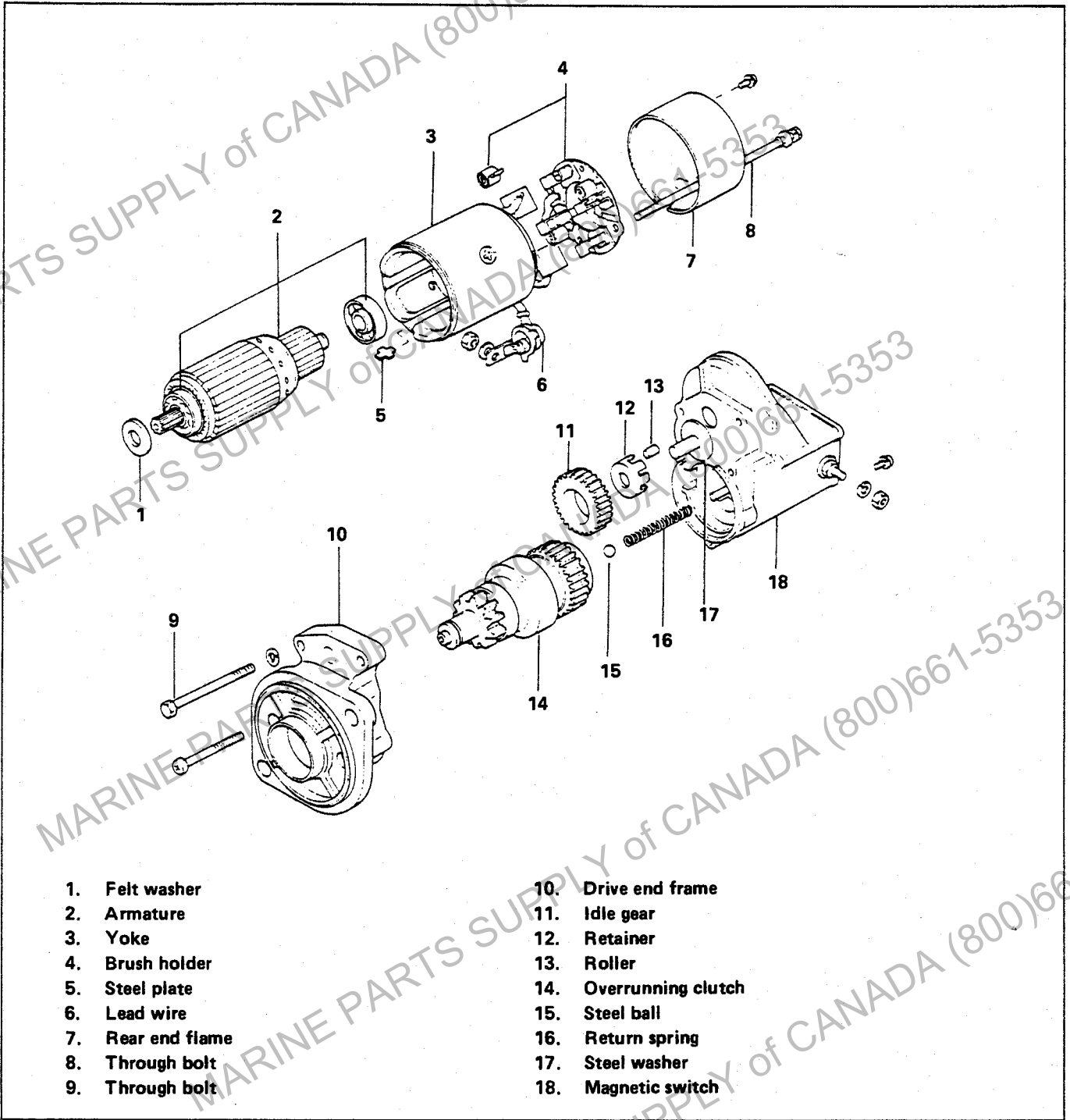

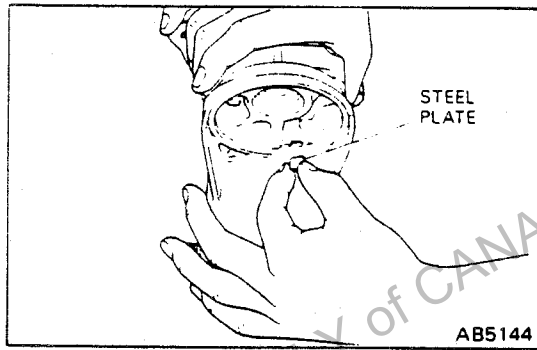
**IMPORTANT POINT (S) – DISASSEMBLY****REMOVE THE YOKE FROM THE MAGNETIC SWITCH.**

1. Disconnect the lead wire from the magnetic switch.
2. Remove the through bolts from the magnetic switch.
3. Remove the steel plate from the magnetic switch.

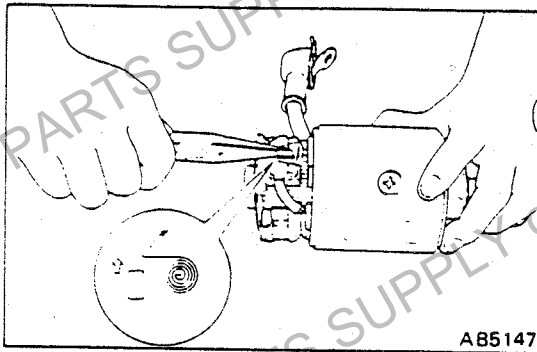
**REMOVE THE ARMATURE FROM THE YOKE.**

1. Remove the rear end frame from the yoke.
2. Using a long-nose pliers, take off the brushes and remove the brush holder.
3. Loosen the two through bolts and detach the brush holder from the armature shaft.

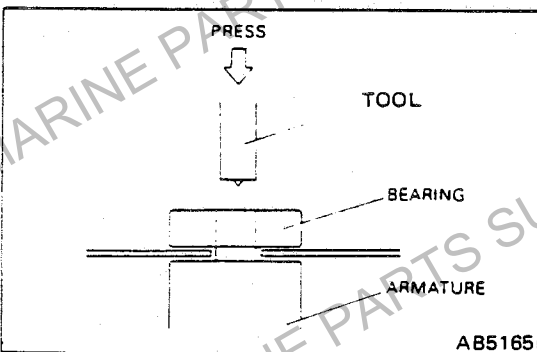
**REMOVE THE BALL BEARING FROM THE ARMATURE.**

1. Using a press and a suitable tool, remove the ball bearing.

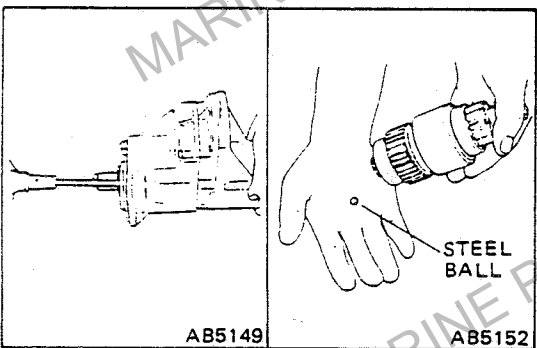
**REMOVE THE OVERRUNNING CLUTCH.**

1. Remove the screws from the drive end frame.
2. Remove the drive end frame from the magnetic switch.
3. Remove the overrunning clutch.
4. Remove the steel ball from the overrunning clutch.

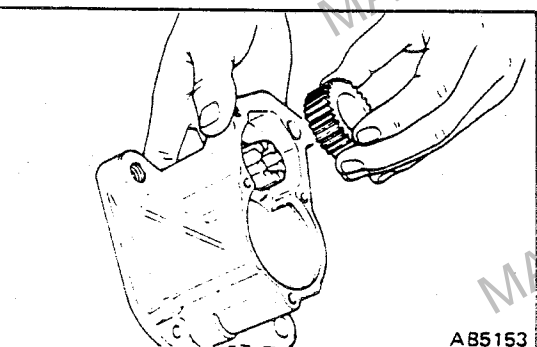
**REMOVE THE IDLE GEAR.**

1. Remove the idle gear, retainer with rollers, and steel washer from the drive end frame.

NOTE: Do not drop the retainer and the rollers.

IMPORTANT POINT (S) – ASSEMBLY

BEFORE REASSEMBLING, APPLY THE RECOMMENDED GREASE TO THE FOLLOWING:

Nippondenso No. 50 grease or equivalent.

- ① Felt washer
- ② Bearing
- ③ Idle gear
- ④ Retainer
- ⑤ Roller
- ⑥ Overrunning clutch
- ⑦ Steel ball
- ⑧ Return spring

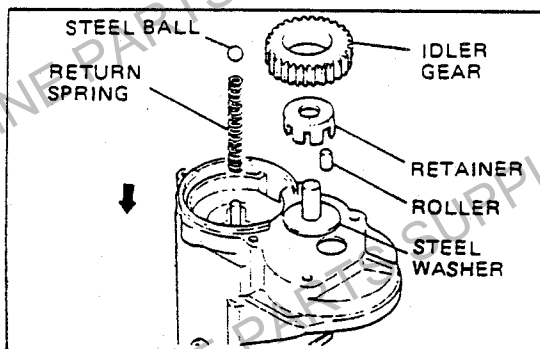
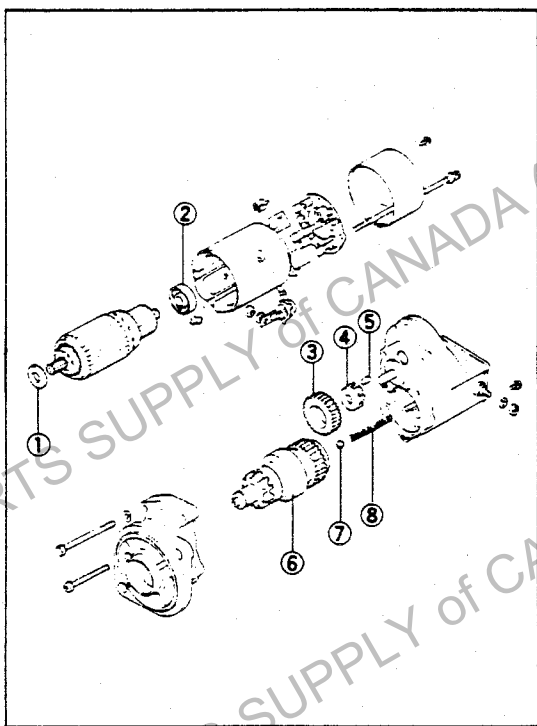

INSTALL THE STEEL WASHER, RETAINER WITH ROLLER, IDLE GEAR, RETURN SPRING, AND STEEL BALL IN THE MAGNETIC SWITCH.

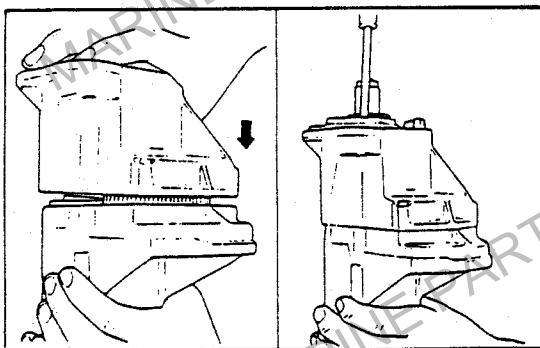

INSTALL THE OVERRUNNING CLUTCH IN THE DRIVE END FRAME.

NOTE: Install the steel ball and the return spring.

1. Connect the drive end frame to the magnetic switch and tighten the screws.

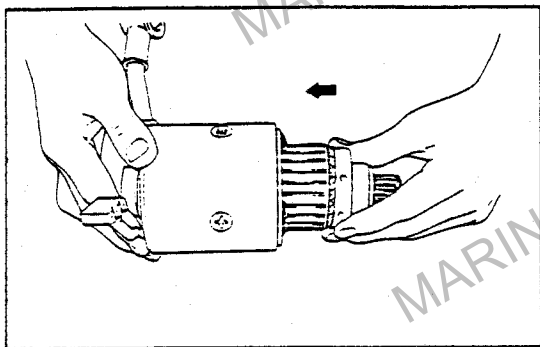

INSTALL THE ARMATURE IN THE YOKE.

NOTE: Do not forget to place a felt washer on the armature shaft bearing.

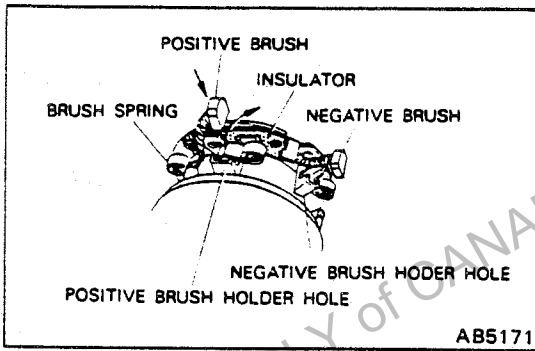

INSTALL THE BRUSH HOLDER ON THE YOKE.

1. Install the negative brush (brush holder side) to the brush holder negative hole (not insulated), and the positive brush (yoke side) to the brush holder positive hole (separated from plate with insulator). Make sure that the positive brush lead wires are not grounded.
2. When assembling the brush holder to the yoke, take care not to damage and get oil on it.

NOTE: Match the lead wire grommet with the rear end frame groove.

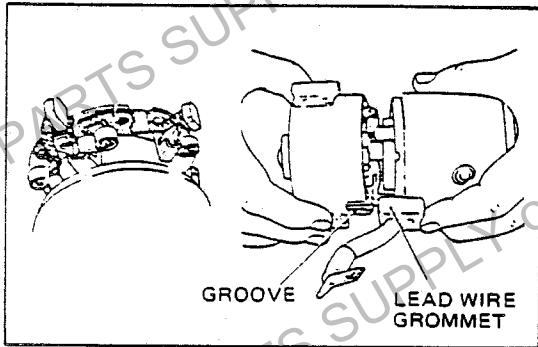

INSTALL THE STEEL PLATE ON THE MAGNETIC SWITCH.

1. Securely put the rubber boot over the terminal.

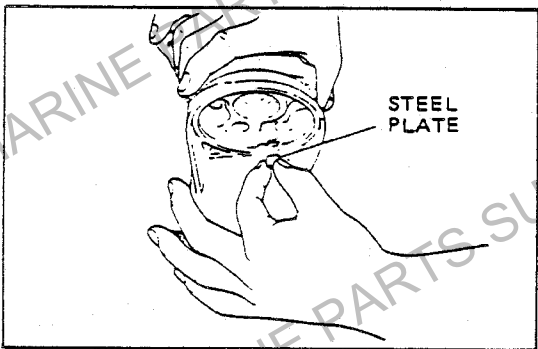

TEST

MAGNETIC SWITCH TEST

The following test should be performed with the starter assembled and the field coil lead wire disconnected.

- NOTE:**
- Each test should be performed for a short time only (3 to 5 sec.) to prevent the magnetic switch winding from burning.
 - Each test should be performed with the specified voltage applied.

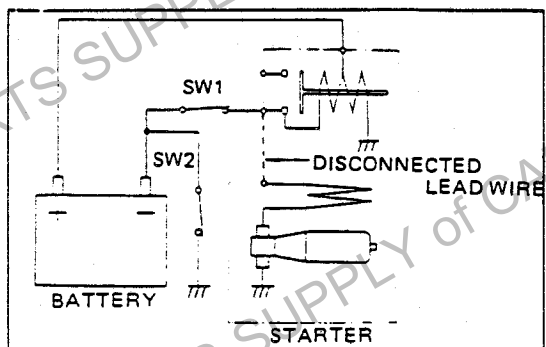

Fig. 22-34

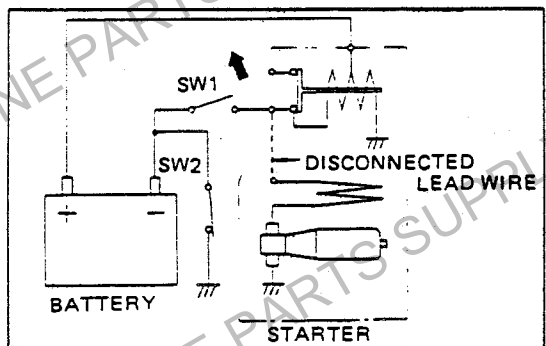
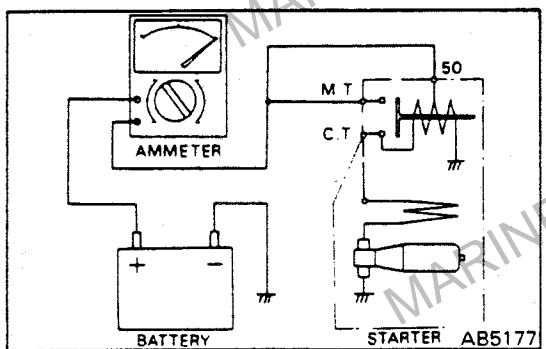
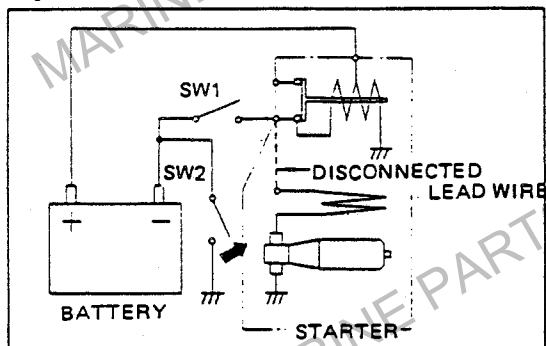

Fig. 22-35



1. **Pull-in test**
Connect the test leads as shown. When switch 1 (SW1) and switch 2 (SW2) are closed, the pinion should jump out.
2. **Hold-in test**
In the same conditions as the pull-in test, open switch 1 (SW1).
The pinion should remain in the jumped out position.
3. **Return test**
In the same conditions as the hold-in test, open switch 2 (SW2).
The pinion should return immediately.

PERFORMANCE TEST

The following test should be carried out after reassembling the starter. If suitable equipment is not available, at least the No-load test should be carried out.

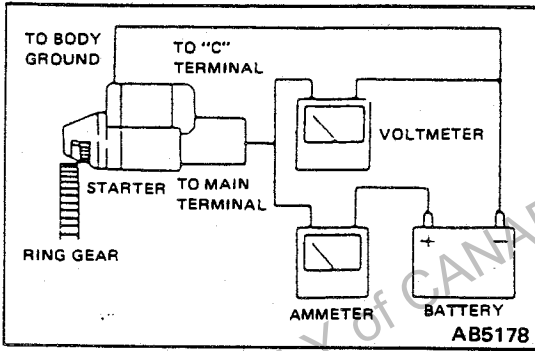

1. **No-load test**
With the starter securely clamped in a vice, and using a battery and suitable ammeter, connect the positive lead of the battery, and the ammeter to the "50" terminal. Connect the negative lead to the starter body. The starter should show smooth and steady rotation immediately after jumping out of the pinion and should draw less than the specified current.



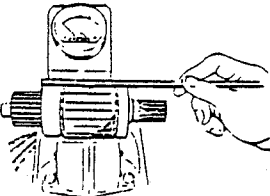
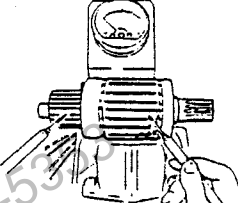
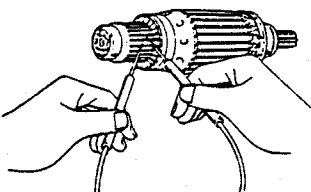
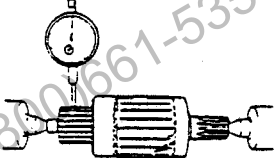
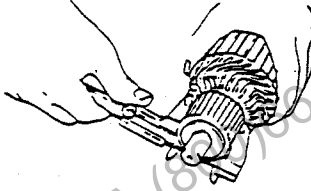

2. **Load test**
Read the ammeter and voltmeter when the specified torque is applied. The ammeter should indicate less than the specified current, and the tachometer should indicate more than the specified speed.
3. **Lock torque test**
Read the torque meter and ammeter when the tachometer reading becomes 0 rpm after applying the load. The torque meter should indicate more than the specified torque and the ammeter should indicate less than the specified current.

	Standard value of each test		
	Current	Voltage	Revolution & torque
No load test	Less than 180 A	at 11V	More than 3,500 rpm
Load test	Less than 600 A	at 8V	More than 1,100 rpm
Lock torque test	Less than 1,200A	at 3V	More than 3.5 kg-m at 0 rpm

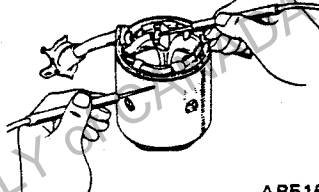
INSPECTION AND REPAIR

Inspection Item	Standard	Limit	Remedy	Inspection Procedure
Armature Short Circuit Test	-		If the iron plate is not vibrated, the armature is good	 <p style="text-align: right;">SMST-091</p>
Armature Insulation	More than 1 MΩ	Less than 0.1 MΩ	Replace	 <p style="text-align: right;">SMST-092</p>
Commutator continuity	Should be continuity at any point	-	Replace, if there is no continuity at any point	
Commutator run-out	Less than 0.02 (0.0008)	0.05 (0.002)	Replace	 <p style="text-align: right;">SMST-093</p>
Commutator Outside Diameter	36 (1.417)	35 (1.378)	Replace	 <p style="text-align: right;">SM22-055</p>
Mica Depth	0.7 (0.0276)	0.2 (0.0078)	Replace	<p style="text-align: center;">COMMUTATOR UNDERCUT</p>  <p style="text-align: right;">SM22-056</p>
Conductance between the Field Coil and the Yoke	Should be conducted		Replace	 <p style="text-align: right;">AB5166</p>

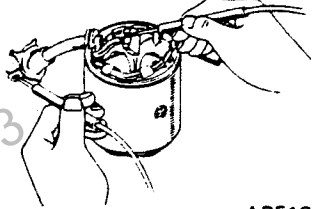
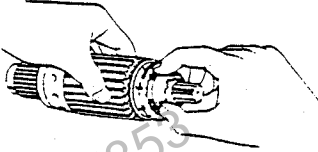
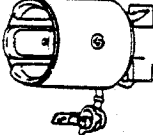
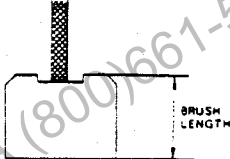
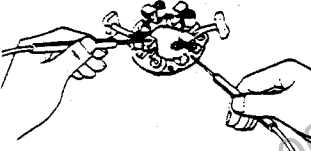
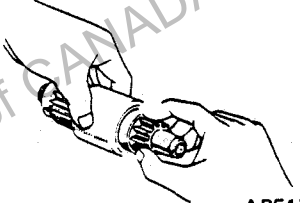
INSPECTION AND REPAIR

Inspection Item	Standard	Limit	Remedy	Inspection Procedure
Field Coil Insulation	More than 1 M Ω	Less than 0.1 M Ω	Replace	 AB5167
Wear or Damage of the Bearing	—	—	Replace, if necessary	 AB5164
Field coil and yoke damage			Replace	Visual check  AB5140
Brush length	20.5 (0.807)	13 (0.512)	Replace	 AB5168
Insulation between the Brush Holder and the Bracket	More than 1 M Ω	Less than 0.1 M Ω	Replace	 AB5169
Overrunning clutch test			Replace	 AB5170
Tension of the Brush Springs	3.9 kg (8.6 lb)	1.9kg (4.2lb)	Replace	

(KY)